

N.S.E.

MARCH 1939

# RADIO INDEX

*The All-Wave Radio Log Authority*



25¢

Staticless Radio  
Foreign Broadcast Reception  
Shortwaves Fully Covered  
Amateur Radio

No. 127

# ILLUMINATED WORLD GLOBE

The illumination from within this 10½ inch "Lumatex" Globe makes it easy to read day and night. Printed in nine colors, the map is as up to date as today's newspaper. The base is of wood, in walnut finish, and the ball is very durable. "Globe Facts" booklet sent with each Globe.

We pay the shipping charges.

**\$5.00**

**RADEX**

362 Cedar Lane Teaneck, N. J.

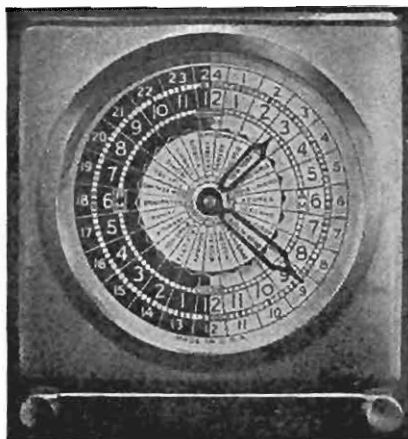

## THE CLOCK THAT CAN BE SET AT ANY OF THE WORLD'S 24 TIME ZONES

Tells time like an ordinary clock and automatically shows authentic time in every other zone around the world.

*Actual size is 5¼ inches high by 4¾ inches wide.*

*Modernistic Design of Brushed Brass*

Just plug it in and set it for the correct time. No further adjustment nor calculation is required.

For AC 110-120 volts, 60 cycles.  
Also available in same style case in spring-driven model at \$4.95. We pay the postage.

**\$5.95**

What DXers Have Always  
Wished For!  
**THE ELECTRIC WORLD-  
TIME CLOCK**

**RADEX, 362 Cedar Lane, Teaneck, N. J.**

MARCH 1, 1939



# RADIO IN DEX



Reg. U. S. Patent Office

FIFTEENTH YEAR

NUMBER 127

PAGE TAYLOR

*Editor*

ASSOCIATE EDITORS

B. FRANCIS DASHIELL

*Technical*

CARLETON LORD

*Broadcast*

RAY LAROCQUE

*Shortwave*

## CONTENTS

PAGE

Cover Girl—Elaine Kent

LEAVES FROM A DXER'S SCRAPBOOK, <i>by Count De Veries</i> .....	4
DXER'S PICTURE GALLERY .....	9
HIGH FREQUENCY GLOBE TROTTING, <i>by Ray LaRocque</i> .....	10
SWL TRADING POST .....	18
WHEN RADIOS SEE SPOTS, <i>by Francis Dasbiell</i> .....	19
ACROSS THE EDITOR'S DESK .....	24
THIS AND THAT IN THE DX WORLD, <i>by Carleton Lord</i> .....	26
STATICLESS RADIO .....	38
AMONG THE CLUBS .....	39
HAM HOUNDING, <i>by "Hugh Huntem"</i> .....	40
STATION NEWS OF THE MONTH .....	46
QUESTIONS AND ANSWERS, <i>by Francis Dasbiell</i> .....	47
S. W. STATIONS AND TWENTY STENTORS.....	49
APPLICATIONS TO THE FCC .....	52
MONTH'S CHANGES IN STATION DATA.....	54

See Subscription Blank on Page 96.

Published monthly except July and August by

**THE RADEX PUBLISHING CO.**

362 Cedar Lane

Teaneck, New Jersey

Subscriptions in the United States and Possessions and in Canada, \$1.75 per year; all other countries, \$2.25 per year. Single copies, 25 cents. Entered as second-class matter Aug. 30, 1938, at the Post Office at Teaneck, N. J., under the Act of March 3, 1879; additional entry as second-class matter at Passaic, N. J. All manuscripts submitted are at the authors' risk, and will not be returned unless accompanied by sufficient postage. Copyright 1939, by the Radex Publishing Co., 362 Cedar Lane, Teaneck, N. J.

PRINTED IN THE U.S.A.

**FOR SALE AT YOUR NEWSSTAND**



## Special After-Midnight Frequency Monitoring Schedules

(OTHER THAN F.C.C. FREQUENCY CHECKS)

<i>Station</i>	<i>Frequency</i>	<i>City and State</i>	<i>Date</i>	<i>Time (E.S.T.)</i>
KTSA	550 K.C.	San Antonio, Texas	1st Monday of Month	1:00 to 1:15 AM
KFGQ	1370 K.C.	Boone, Iowa	1st Monday of Month	2:30 to 3:00 AM
WBBZ	1200 K.C.	Ponca City, Okla.	1st Monday of Month	6:00 to 6:30 AM
KLAH	1210 K.C.	Carlsbad, New Mexico	1st Tuesday of Month	5:00 to 5:30 AM
KAND	1310 K.C.	Corsicana, Texas	1st Tuesday of Month	5:15 to 5:45 AM
KWOS	1310 K.C.	Jefferson City, Mo.	1st Wednesday of Month	2:00 to 2:30 AM
WSAU	1370 K.C.	Wausau, Wisconsin	1st Wednesday of Month	2:30 to 2:45 AM
KPAB	1500 K.C.	Laredo, Texas.	1st Wednesday of Month	2:30 to 3:00 AM
WAVE	940 K.C.	Louisville, Ky.	1st Thursday of Month	1:30 to 1:45 AM
KNOW	1500 K.C.	Austin, Texas.	1st Thursday of Month	1:45 to 2:15 AM
KTRI	1420 K.C.	Sioux City, Iowa.	1st Thursday of Month	2:00 to 2:30 AM
WGRC	1370 K.C.	New Albany, Indiana.	1st Thursday of Month	2:30 to 3:00 AM
WACO	1420 K.C.	Waco, Texas.	1st Friday of Month	1:45 to 2:15 AM
KGFI	1500 K.C.	Brownsville, Texas	1st Friday of Month	2:00 to 2:30 AM
KIUN	1420 K.C.	Pecos, Texas.	1st Friday of Month	2:30 to 3:00 AM
KEUB	1420 K.C.	Price, Utah.	1st Saturday of Month	2:00 to 2:30 AM
KSAL	1500 K.C.	Salina, Kansas.	1st Saturday of Month	2:30 to 3:00 AM
KWOC	1310 K.C.	Poplar Bluff, Mo.	On Sunday Morning pre- ceding 2nd Tuesday of every Month.	2:00 to 2:30 AM
WPAY	1370 K.C.	Portsmouth, Ohio	On 1st Day of Month	4:00 to 4:30 AM
KTEM	1370 K.C.	Temple, Texas.	On 5th Day of Month	3:00 to 3:30 AM
KVGB	1370 K.C.	Great Bend, Kansas	On 7th Day of Month	3:00 to 3:20 AM
WPAD	1420 K.C.	Paducah, Kentucky.	On 7th Day of Month.	3:00 to 3:30 AM
WTAQ	1330 K.C.	Green Bay, Wis.	2nd Tuesday of Month	4:15 to 4:30 AM
WCAZ	1070 K.C.	Carthage, Illinois.	2nd Saturday of Month	3:30 to 4:00 AM
KWBG	1420 K.C.	Hutchinson, Kansas.	1st and 3rd Wednesday	6:30 to 7:00 AM
KGFW	1310 K.C.	Kearney, Nebraska.	On 15th and 29th of Mo.	2:00 to 2:30 AM
KBIX	1500 K.C.	Muskogee, Oklahoma.	4th Saturday of Month.	5:00 to 5:15 AM
WLAP	1420 K.C.	Lexington, Kentucky.	On last Friday of Month.	2:00 to 2:30 AM
WSUI	880 K.C.	Iowa City, Iowa.	On Wed. Morning pre- ceding 1st Saturday of every Month.	



● Foreign reception is a wonderful thing—particularly on the broadcast band. Ask any DXer you know, and he'll tell you it's sure a great thrill when you can dig down in the kilocycles and come up with a Frenchie or an Aussie in one hand, and have the other hand free for writing down a lot of stuff for a verifiable report.

Foreign reception is also kind of tough—at least that's what the DXer will tell you when he's been concentrating on the broadcast band. None of that easy-meat short wave stuff, but hard enough for you to appreciate a foreign catch when you hear it.

At first, people weren't so sure whether you could hear those babies from across the pond. In the Middle Twenties, when practically every radio owner was a potential DXer, a few of the boys did reach across the Atlantic to snare a few signals from England and Spain. Those were the days of "silent nights" and international tests. And occasionally you heard of someone who had heard Australia or South America.

But every time you went out to tell a chap about hearing 2BD, 3LM, 2LO or 5NO, he'd stick his tongue in his cheek and ask you if he'd ever told you about the big one that got away. On his horizon, PWX, 6KW, XWA, CZE, CZL and WKAQ were

the limits of foreign DX. And KHJ and KFI were still mighty good catches for any man's log.

However, little by little, foreign reception began to be a more or less accepted fact. Not an everyday occurrence, mind you, but something which might happen once a year, if the moon was right and if Gemini didn't get tangled up with Sagittarius on Twelfth Night.

Around the dawn of the current decade, a Chicago engineer by the name of Scott started building receivers which could and did hear stations in Australia. Listeners began to report "freakish" reception of European and Asiatic broadcasters. A Pacific Coast radio dealer offered a hundred dollars to any given charity if he couldn't tune in a Japanese station before witnesses. Newspapers and magazines played up this remarkable reception, while Johnny D. Exer stood in awe of this seeming miracle. Foreign reception was here, even if we could scarcely believe it.

The transition during the next couple of years was almost unbelievable. DXing was becoming an organized hobby. Radio clubs were formed, with members exchanging reception tips. One listener would hear a station in Europe or Australia, he'd report it in the bulletin of his club,

other members would try for the station, and the chances were excellent that they, too, would hear it. Perhaps not at the first trial, for foreign reception has always been tricky, but eventually they would get it. And so it went, with interest in the fascinating new angle of radio spreading like wildfire.

The 1931-32 season was perhaps the first in which the average listener could report any degree of success—for the most part, he was referred to a few scattered stations in Europe and New Zealand. The following season showed an even more advance in foreign reception. This was the season when the famous cricket games from Poste Parisien amazed and delighted hundreds of American DXers, opening their eyes to the possibilities of trans-Atlantic reception. This was the winter when the International DXers' Alliance was organized—the first radio society to devote its interest exclusively to foreign reception.

The next two seasons found interest in overseas DX continuing to increase by leaps and bounds. Listeners with just average receiving equipment were able to report a goodly number of stations in Europe and Australia, while those with expensive custom-built models could boast of dozens of good catches from across the Atlantic and the Pacific. It was during the 1933-34 that South America loomed as yet another DX target. Specials from HJN, YV1RC (then known as YV1BC), CP4, CX26 and YV3BC were heard by scores of DXers in the United States. And what listener will

**Old Line Legal Reserve**  
**LIFE INSURANCE**

Only **77<sup>c</sup>** PER MONTH  
 PER \$1000  
 OF INSURANCE  
 (AT AGE 21)\*

**HERE ARE LOW RATES  
 AT YOUR AGE**

(Rates shown are one-half permanent rates beginning fifth year.)

**MONTHLY PREMIUM LESS THE 9½%  
 GUARANTEED DIVIDEND (at age  
 nearest birthday), per \$1,000**

Age	Age	Age	Age
21 \$ .77	30 \$ .97	39 \$ 1.29	48 \$ 1.87
22 .79	31 1.00	40 1.35	49 1.95
23 .81	32 1.03	41 1.39	50 2.04
24 .83	33 1.06	42 1.45	51 2.15
25 .85	34 1.09	43 1.51	52 2.27
26 .87	35 1.13	44 1.57	53 2.39
27 .90	36 1.16	45 1.64	54 2.53
28 .92	37 1.21	46 1.70	55 2.66
29 .95	38 1.25	47 1.79	

A further saving is made by paying premium annually or semi-annually.

\*Owing to low rates at which this policy is offered, the minimum amounts issued are: ages 21 to 45, \$1,500; 46 to 55, \$1,000.

**POSTAL'S FAMOUS "MODIFIED '4' " POLICY.** Cash and loan values; guarantee 9½% dividends; automatic premium payment clause and all standard provisions.

**OVER \$48,000,000.00 PAID OUT** by POSTAL LIFE OF NEW YORK to its policy holders and beneficiaries during thirty-three successful years.

**Send coupon for full details.**



Postal Life Insurance Company  
 511 Fifth Ave., Dept. M-518  
 New York, N. Y.

Send me without obligation complete information about your low-cost Modified "4" policy at my age.

Date of Birth .....

Occupation .....

Name .....

Street .....

City..... State.....

ever forget the thrill of hearing LR5 turn on its carrier, one cold December morning in 1933, and completely overshadow KOA which had not as yet signed off?

After the 1934-35 season, foreign reception began to fall off a bit. Signals from the most powerful overseas stations lacked their former punch, and the smaller stations had to struggle to show above the general noise level. You began to hear talk about sunspots being on the uptrend of their 11-year cycle. You had to have some explanation for heavy static, loud surging noises, abnormally heavy fading and impotent signals, so these hickies on the sun's countenance came in for the blame.

Real DX was out until 1940, you'd hear listeners lament, as they ordered an extra supply of crying towels. No sense in staying up for the TA's and TP's, they'd complain, for they simply won't come in. What if Randy Tomlinson did hear 50 Europeans during the 1935-36 season and Ray Lewis finished up verifying all the stations in Italy? They have Scott receivers and I couldn't touch those catches with my little percolator.

Small wonder that foreign DX went into a tailspin for a couple of seasons and lots of listeners concentrated on domestic reception! They didn't believe that the nasty old sunspots would let them hear an overseas station, and so they simply didn't try.

And yet, while reception during the 1935-36 and 1936-37 seasons was admittedly below par, a few listeners continued to drag in occasional catches from Europe, South America and Australia. Not as good as they were a few years back, perhaps, but

still the signals could be heard if you had the patience and perseverance to go after them.

For every downgrade, there is usually an uptrend, and DXing is no exception. In the minds of not a few DXers, the 1937-38 season marked, not only the bottom of the hill, but the start of the climb back to the heights.

As early as the middle of November in 1937, the Europeans began to push through with a semblance of their old-time punch. Rennes on 1040 was mistaken for KRLD on a morning which found Lille, Bordeaux, Nice, Poste Parisien, Stuttgart and Hamburg coming through with real wallop. On subsequent mornings, from seven to ten Europeans could be heard with really excellent signal strength.

And that wasn't all! The Aussies and Zedders began to perk up and show a little life. 2YA resumed its place at the head of the Zedders, closely followed by 1YA and 3YA; while, from Australia, 2NR, 2BL, 2CO and 3LO led a parade of really decent catches. South America did itself proud with a formidable array of stations which included LS2, LR1, LS4, LR5, PRA9, LRA, HJ3ABH, OAX4A and many others.

It began to look as though American DXers were in for an old-fashioned siege of foreign catches again. Reports in RADEX and in various club bulletins indicated that the boys were beginning to pull them in again. Scientists announced that the sunspot cycle had at last turned toward a decline in activity, which meant better reception. And so it wasn't long before readers began to write in for



more dope on the overseas stations, lists of the foreign broadcasters, and tips on how and when and where to hear 'em.

As a result, I set about the job for preparing the series of three articles on foreign reception which appeared in the October, November and December issues of RADEX.

By no means was this to be construed as an effort on my part to set myself up as an authority on overseas reception, even though I have never felt it necessary to belittle my log of foreign catches. As the result of eight years of more or less leisurely DXing, I could point to a list which included: in South America—LS2, LRA, LR1, LR4, LR5, CPX, CP4, HJN, CX26, YV1RC, YV3BC, YV5RA, YV5RQ, YV1RF, HJ3ABH, HJ3ABD and HJ3ABE; in Europe—Strasbourg, Lille, Rennes, Bordeaux, Toulouse, Nice, Poste Parisien, Radio Normandie, the Scottish and North Nationals, Sottens, SBH, Turin, Milan, Rome I, Berlin, Frankfurt-am-Main, Stuttgart, Munich and Hamburg; in Africa—Radio Algiers; and in the Antipodes—1YA, 2YA, 3YA, 2CO, 2BL, 2KY, 2NR, 2NZ, 2CH, 2NC, 3AR, 3LO, 4QG, 4RK, OQN, 5CL, 5CK, 7ZL and 7NT. Admittedly I had used good equipment—Scott receivers during the past six years—but there are other DXers whose foreign logs are larger and whose grand total of veries exceeds my thousand odd.

Still, the articles had to be prepared by someone, and so they were written up to include all the tips I had ever heard, all the advice that had been given to me, and all the points which I had learned from my own experi-

ence. I hoped that they might be of some help to the less-experienced DXers and that they would contain a few pointers for even the old timers.

Since the appearance of the last of these articles, there have been an increasing number of reports on foreign reception. Listeners seem to be finding the going much easier than in recent seasons, and their letters indicate that they are getting more than their share of overseas stations.

But even the most encouraging of reports must rank second to that just received from Evan B. Roberts, Wenham St., Danvers, Mass., who writes:

"All DXing here is confined to the broadcast band, and to foreign stations 2000 miles or more distant and outside of the North American Continent. Even with these limitations, it has been possible to average 40 verifications each year for the past six years. At present, the log here stands at 243 veries from 53 countries—123 from Europe, 24 from South America, 45 from Australia, 22 from Japan, seven from New Zealand, four from Central America, and three each from Africa, Asia and Hawaii. Enough reports are out now so that, with any kind of a good response, the grand total will reach 300, the European total nearly 200, with Africa hitting number five.

"The prime motive behind this letter is to report the extraordinary trans-Atlantic reception during the past 15 days. Having more or less concentrated on these stations for the past six years, I can state that there has never been a period of DX reception which excelled this recent spell, and possibly no period even approached it. To be able to hear, well

enough to log and verify, nearly 160 different European stations, from every country except Greece and Albania, is certainly reception with which no one could find fault. And it goes to prove that foreign BCB DXing is not as passe as one is generally led to believe.

A word about Mr. Roberts' equipment should be interesting to all Radexers. For receivers, he uses a 23-tube Scott superheterodyne and 11-tube Hallicrafters marine model. He has a choice of aerials—one 425 feet long, directional to Northeast; one 300 feet long, directional to the Southwest; one 275 feet long, directional to the South; and one non-directional vertical aerial, 50 feet high.

While it is granted that such an installation, to which much of his success may be attributed, is beyond the means of the average DXer, that does not mean that even ordinary equipment will not bring surprising results if it is used intelligently.

As he points out in his letter, "Most DXers seem to think that broadcast band DXing won't be worth their while until 1941 or 1942, and consequently they just refuse to give it a decent trial."

And there, mates, is a thought worth plenty of mulling around in the old brain cells.

---

#### NEWSSTAND BUYERS

If your newsdealer is unable to supply you with your copy of RADEX you may order form on page 96 of your last copy. obtain the issue you want by using the

#### LARRY LUNDBERG

Larry Lundberg, a Minnapolis DXer, is shown in the photo on the opposite page, with many of the cards and pictures he has collected. He solicits QSL cards from stations on the amateur bands, the short-wave broadcasts, and the standard broadcast band. At present his collection numbers about 600 cards on the broadcast band, including some from New Zealand, Australia, Hawaii, Alaska, and many other countries.

#### SAM GRAHAM

The photograph of Sam Graham shown on the opposite page was made by himself, and enlarged from a 35 mm. negative. His two main hobbies are photography and DXing. He has been tuning for about a year and a half, and has verified all the continents, and all the states, on the shortwaves. He finds the 10 meter amateurs especially interesting. The clubs which count Sam as a member are The Radex Club (R76), the IDA, ILA, ISWC and WWHC.

#### PETER A. CLARIUS

Peter Clarius and Peggy. This DXing "team" has heard 637 stations on the broadcast band. Peggy is an Eskimo Spitz, and Peter says that every time she relaxes in his radio den, he logs a new station. Of the 637 heard, 573 have been verified, including the 48 states and several foreign countries. Biggest thrill since tuning was a dedication from WBNY, Buffalo, when station first came on air. Best verification, KXO. Clubs are The Radex Club (R6, N.Y. 2), the NNRC, and NRC.

Everyone who submits a photograph which is used receives a free copy of the issue in which the picture appears, or if he is a subscriber, his subscription is extended an additional copy. If you have some good-looking QSL cards, unusual views of radio stations, or a good snapshot of yourself in your radio den, send them along—we will take good care of them, and if we can use them, you will get your RADEX for nothing. Fair enough?

# Dxers' Picture Gallery



*PETER A. CLARIUS*



*SAM GRAHAM*



*LARRY LUNDBERG*



*CHARLES C. NORTON*

Charles C. Norton, of San Francisco and San Diego, California, is the president of the Universal Radio DX Club.

# HIGH FREQUENCY GLOBE TROTTING

●●● By RAY LA ROCQUE



## Report-O-Meter

Carl and Anne Eder . . . . .	100%
C. J. Fern, Jr. . . . .	100%
Ed. Lang . . . . .	67%
Gilbert Harris . . . . .	50%
Caribbean Listening Post . . . . .	50%



Top spot in the Report-o-Meter this month is shared by two persons. In fact it is shared by three, but our good friends, the Eders, prefer to report as one so we'll say two persons. A tie also occurred in the rating for fourth position in the meter, thus eliminating fifth place. Oddly enough, none of the favored five was so much as listed last month, and only the Eders have ever before appeared in the listing—that was in January when they barely reached fifth place!

We were forced to allow only the exact amount of points scored for scoop box reports. No bonus was allowed as we promised, because it made the "Report-o-Meter" a game of chance and we want it to be just the opposite. We want it to be a game where skill and effort count above everything else. Then too, we were fearful less it should cause reporters to hold back reports till the last minute hoping to have them included in the Scoop Box. So, with this issue, we will credit the same amount of points for Scoop Box re-

ports as for regular reports—of course, we'll have to credit Scoop Box scores on the following month's "Report-o-Meter". Also, we are counting reports for our new department, "The Not-so-Short Waves," in the "Report-o-Meter."

### MEGACYCLE BREVITIES

ZRK, according to Richard Neller of Niagara Falls, N. Y. is closer to 9615 kcs. than to their official frequency of 9606 kcs. . . . W2XMN, an ultra high station assigned to operate on 42800 kcs., with a power of 40000 watts has been granted extension of its special temporary authority to operate according to the above specifications. The station located at North Alpine, N. J., has a little story behind it. Our member William Wood (R24-111.5) of Oak Park, Ill. sends us a clipping relative to W2XMN. The clipping states that the broadcasting station will take air with a signal that will defy all kinds of static. Static free broadcasting will be effected, it is said, by a new means of broadcasting and reception invented by Edwin H. Armstrong, Professor of Electrical Engineering at Columbia University. The system is called the frequency modulation method of transmission and differs greatly from the present amplitude modulation method. The station is scheduled to take the air in the spring of this year. It will be interesting to hear its first broadcast. (See article "Staticless Radio" in this issue of RADEX. Ed.) Chet Brown (R149), of Bradford, Pa., asks about a station WET heard testing with WNBW. WET was on 9470 kcs. and asked WNBW to change to 8 megacycles. WNBW is licensed to

the NBC for operation aboard the SS Santa Maria on frequencies of 4797.5, 6425, 8655, 12862.5, and 17310 kcs. WET is at Rocky Point, N. Y.

Stanley Fairchild (R545), of Toronto, Ontario wants to know what station uses various bird calls for their signature at the close of each program. All the 12RO transmitters use the familiar canary bird calls at the beginning and end of each program and if friend Fairchild will name the frequency, we may be able to enlighten him as to their exact call letters.

#### QUOTE AND UNQUOTE

*Pat Webb, San Antonio, Texas:* "W2XAA on 12862.5 kcs. heard announcing at approximately 15 minute intervals using a telephone mike: 'This is station W2XAA, Chicago, Ill., operating on a frequency of 12862.5 kcs. by authority of the FCC.' Then sometimes they call New York, but I have never heard any conversation between them. I have heard the station as early as nine a.m. and as late as two p.m. local time. Now, how can there be a 'W2' call in the ninth district?"

*C. J. Fern, Libue, Hawaii:* "A mystery station still unidentified on 5300 kcs. Languages used cannot be identified, but they use both male and female announcers. Signal is QSA4, R9. They were picked up at 8:30 p.m. and were still on the air at 9 p.m."

*Robert Skyten, East Brookfield, Mass.:* "Stations believed to be in Norway are heard on 11730 and 9610 kcs. The 11730 kcs. station is heard mornings, and on about 9610 kcs. in the afternoon and evening. No call letters



*From the Garden of the Pacific, the Fiji Islands, comes this photographic QSL card. The station is VPD2, in Suva, a broadcasting station operated by the Amalgamated Wireless, Australasia, Ltd., operators of VK2ME and VK3ME in Australia. (Courtesy of Al. Bartholomew, Herman Schafer and Capt. E. N. Massey.)*

heard, but 'Oslo' was mentioned." *A. M. Hankins, Latrobe, Pennsylvania:* "Can anyone identify this station: Frequency approximately 11920 kcs. Station is Spanish speaking with varied music including Latin and North American dance recordings. They come on the air at 6:45 p.m. and sign off at 10:30 p.m. Announcer speaks very very rapidly and I am almost positive he says 'Radio Caracas' in his closing announcements in Spanish."

#### ULTRA HIGH

W1XOJ on 43000 kcs. in Paxton, Mass. has been granted an extension of its authority to test with 100 watts. They do not have a permanent license because definite frequency assignments have not been made yet on the ultra high bands. (RX) The station is still under construction and not operating yet. (RL-Mass.)

W1XPW on 43400 kcs. with 1000 watts in Hartford, Conn., is again granted an extension on its operating

license. Permanent license cannot be granted for same reason as W1XOJ. (RX)

W2XJI on 26300 kcs. in Newark, N. J. heard here from 1:26-1:45 p.m. with an R8 signal. (Bettinger-Nebr.)

W2XQO on 26550 kcs. in Flushing, New York is heard in the afternoon from 2:05-3:34 p.m. with R8 plus signal. (Bettinger-Nebr.)

W5XD on 31600 kcs. at Dallas, Texas relays programs of WFAA daily from 11:30 a.m. to 1:30 p.m. W5XD was designed and constructed by the engineering staff of WFAA, under the direction of Raymond Collins, WFAA technical supervisor, and is operated by the Dallas News. It is planned to expand the schedule of W5XD later in order to take on musical, cultural, and educational programs not now available. Dick Jordan of the station promises to keep us posted on new developments. (RX)

W8XWJ on 41000 kcs. in Detroit, Mich. is now operating on a new schedule. Monday to and including Saturday from 10 a.m. to 5 p.m. with no transmissions on Sunday. (Ritzenheim-Mich.)

W9XA on 26450 kcs. in Kansas City will operate daily from noon to 4 p.m. There may be other programs but this schedule will be their consistent daily schedule. The time, it will be noted, was chosen because it covers the noon hour in each of the four U. S. A. time zones. (R651---W9XA-Mo.)

W9XJL on 26100 kcs. in Superior, Wisconsin is heard R7-8 and verifies with a nifty post card. (Podall-Vt.)

W9XLA on 31600, 35600, 38600, or 41000 kcs. in Denver, Colorado

has been granted construction permit for a new ultra high frequency broadcast station to use 100 watts. The station is to be owned by KLZ, and will doubtless relay the programs of that station. License has been granted conditionally pending definite assignments on the ultra high frequency bands. (RX)

W9XTC on 26050 kcs. in Minneapolis, Minnesota is heard R7-8. (Podall-Vt.)

W9XUP on 25950 kcs. at St. Paul, Minnesota relaying KSTP is heard R7-8. (Podall-Vt.)

W9XUY on 31600 kcs. in Omaha, Nebraska (KOIL programs) is actually on 31620 kcs. according to calibration of C. J. Fern of Hawaii, where they are heard regularly. (R211—T.H.2)

#### VERI NEWS AND NEW VERIES

None of the Swedish stations have veri cards, according to John Macrea (R473) of Winnipeg, Man. They reply by letter enclosing a time table.

W1OXAB's cards are now being mailed out (Trubee-N. J.)

ZIZ on 6384 kcs. verifies with a typed letter stating that their 1939 card will be ready soon. (Trubee-N. J.)

Radio Nacional verified on a report when they were in Salamanca with a brown and white card. The words "Radio Nacionals, Salamanca are printed in brown. (Trubee-N. J.)

WWV on 5000 kcs., 10000 kcs., and 15000 kcs., send a veri on a post-card with  $\frac{3}{4}$  inch letters. Send reports to National Bureau of Standards, Beltsville, Md. (R671-N. J.)

**THE "NOT SO SHORT" WAVES**

Due to an increasing amount of interest in commercial and emergency stations operating on the frequencies in between the regular shortwave broadcast bands and the standard broadcast band, we feel it necessary to devote a few paragraphs to this phase of DXing each month, particularly since the tropical countries have adopted them as a haven of escape from the crowded standard broadcast and shortwave broadcast bands. Whether this department is continued or discontinued depends solely on the interest displayed by readers.

Answering the question of W. C. Post of St. Paul, Chester Roman of Chicago states that WANC, KIPQ, KIPR, and KIPT (not KIDT) do verify along with all other special emergency stations. These stations request reports from listeners.

SOS! Help is wanted by Chester Roman (R451), Chicago, Ill. in identifying the following: "U.S.G.G. 'Algonquin' on 2670 kcs., at 9 p.m.; Chicago Division Portable on 2670, 2688, 2692, and 2698 kcs. at 10 p.m. as well as U.S.C.G. 'Ossipe' on the same channels at the same hour.

Then Patrol Boat '119' on 2670 kcs., Point Judith, R. I. on 2676 kcs. at 9:45 p.m., Charlevoix, Michigan on 2692 kcs. at 7 p.m., Bird's Island, Mass. on 2670 kcs. at 9:15 p.m., Dennis Cove Island, Mass. on 2670 kcs. at 9:15 p.m., U.S.C.G. '190' on 2676 kcs. at 8 p.m., Grand Haven, Mich. on 2692 kcs., at 7 p.m., U.S.C.G. 'Manhattan' on 2676 kcs., at 8:30 p.m. A ship, KFEI, was heard on 2670 kcs. on Jan. 26 at 9:25 p.m. calling KJRU and NMF at Winthrop,

Mass. NMC on 2662 kcs. at Point Bonita, San Francisco, Calif. heard at 10:20 p.m. with an R7 signal giving a weather report. (R451-III.)

WANA on 2726 kcs. in Homer-ville, Georgia heard calling WANB of Dinsmore, Fla. WANA is operated by the Consolidated Timber Protective Organization. This is the 12th special emergency station heard here since September. (R451-III.)

HOA on 2340 kcs. at Panama City, Panama is heard on the air daily from 8-10 p.m. in parallel with HP5G. The station's slogan is "Ron Dalley" and the theme is "Prelude from Traviata". (R591-P.R., and R211-T.H.2)

COKH on 2200 kcs. in Santiago heard relaying CMKH in the evening around 9 p.m. (R591-P.R.)

**SHORTWAVES IN REVIEW****Angola**

CR6AA on 77:45 kcs. is heard from 2-4:15 p.m. on Mondays, Wednesdays, and Saturdays using two kilowatts. His official frequency is supposed to be on 7614 kcs., but this is where he will be found on the dial. (RL-Mass.)

**Argentina**

LRA-5 on 17830 kcs. is heard from 3-4 p.m. on Fridays only. (RL-Mass.)

**Australia**

VLR on 9580 kcs. in Melbourne comes in R8-9 usually when reception is good. News bulletins are heard at 7:30 a.m. followed by weather report and horse racing results. (Skyten-Mass.)

VLR-3 on 11880 kcs. is heard between 1 and 3 p.m. but is bothered by CW QRM. (R211-T.H.2)

**Bolivia**

CP-5 on 6190 kcs. is heard in the

evening daily. Exact schedule not known. (RL-Mass.)

#### Chile

CB-970 on 9715 kcs. is heard nightly to 11:30 p.m. relaying CB76 at Valparaiso. (R211-T.H.2)

CD-1190 on 11900 kcs. in Valdivia, signed off at 10:15 p.m. recently and gave the station and wavelength in English. (RL-Mass.)

#### China

XGOX on 15190 kcs. heard first at 7 p.m. but now comes on the air at 12:30 p.m. (RL-Mass.)

#### Cuba

COGF on 11805 kcs. at Matanzas signs off at 10 p.m. on Tuesday with an organ selection after the station identification. (R21-Pa.3)

COKG on 8965 kcs. signs off at 10:30 p.m. on Mondays with lady announcing call letters in English and giving station address as P. O. Box 100. They sign off with "Good Night Ladies." (R21-Pa.3)

#### Czechoslovakia

OLR5C on 15160 kcs. is heard daily from 1-1:30 p.m. If OLR5C is not heard try OLR4D at the same time. (RL-Mass.)

#### Denmark

An unknown station is heard on 15320 kcs. on Sunday instead of OZH on 15136 kcs. (RL-Mass.)

OIE on 15190 kcs. is heard in the morning irregularly. (RL-Mass.)

#### Ecuador

HCJB on 14420 kcs. at Quito signs off at 10:15 p.m. and requests correct reports and they will send QSL cards to all listeners. They broadcast every day except Monday. (R21-Pa.3)

#### French Indo China

"Radio Hanoi-II" on 11890 kcs. has been heard regularly in the mornings until about 9:27 a.m. when they sign

off with the announcement, "Ici Radio Hanoi" and "La Marseillaise" French National Anthem. (Skyten-Mass.)

#### Guatemala

TGWB on 6490 kcs., and TGWA on 15170 kcs. along with broadcast station TGW are on the air daily from 12:15 p.m. TGWA signs off at 1:15 p.m., but the others continue until midnight. (R671-N. J.)

#### Haiti

HH3W on 9645 kcs. at Port-au-Prince are now signing off at 9:10 p.m., EST with call letters in English. (R21-Pa.3)

#### Honduras

HRN on 5875 kcs. at Tegucigalpa heard on a Sunday night from 9:17 to 9:49 p.m. when they signed off with the selection "Goodnight". Station and frequency was identified in English at sign off. (R21-Pa.3)

#### Hungary

HAT-4 of Budapest send a white, green, and red card giving much useful data. In the center is pasted a candid snapshot of the St. Gellent Artificial Wave Bath. (R671-N. J.)

#### India

VUD-2 on 9590 kcs. is heard in the morning around 8 a.m. and in the evening around 9:30 p.m. The signal is about the same at both times. The frequency is not exactly 9590 kcs. as they come in on the high frequency side of PCJ and they are closer to 9593 or 9595 kcs. (Bettinger-Nebr.)

Delhi, on 15290 kcs. heard daily from 9:30-11 p.m. Definite identification is not certain.

#### Italy

12RO has several frequencies; not commonly used, which are not known to the average shortwave fan. They are:



2RO-7	17170 kcs.	2RO-2	6930 kcs.
2RO-8	17820 kcs.	2RO-3	9635 kcs.
2RO-9	9670 kcs.	2RO-4	11810 kcs.
2RO-10	15190 kcs.	2RO-5	15170 kcs.
2RO-11	7220 kcs.	2RO-6	15300 kcs.
2RO-1	6035 kcs.		

(R184-5, Minn.)

IQY on 11676 kcs. is heard daily from 12:10-1 p.m. They verify on an IRF card. (R671-N. J.)

I2RO-6 on 15300 kcs., another Rome experimental frequency has been heard at various times of the morning and early afternoon. The station carries a few programs and is also often heard modulated by a high frequency note. They are identified by the usual canary bird interludes used by Italian stations and by a woman announcer. (Pat Webb-Texas, and RL-Mass.)

I2RO-9 on 9670 kcs. comes in a good R9 from about 3 to 7 p.m. Most of the time it carries the programs of 2RO, but occasionally has a different program, seemingly that of the Rome standard broadcast station. It carries the first part of the South American hour beginning at 6 p.m., but no announcement is made as to its call letters. Like other Rome stations it uses a canary bird's song between programs. It is usually the loudest station from Europe on the band. (Pat Webb-Texas, and RL-Mass.)

#### Japan

JVT on 6750 kcs. at Nazaki has been heard on several mornings at 1:30 a.m. with excellent signals, transmitting in Japanese. (Skyten-Mass.)

#### Martinique

"Radio Martinique" on 9700 kcs., is broadcasting regularly and just before sign off at 10:32 p.m. they give the name of the transmitter and ask

for reports on their signal. The location is Fort de France, Martinique. (Bonnell-Ohio)

#### Mexico

XEWI on 11900 kcs. at Mexico City signs off on Tuesday with orchestral selection after station identification at 10:15 p.m. (R21-Pa.3)

#### Norway

LKV on 15170 kcs. in Oslo is heard in the morning until TGWA comes on the air at 12:30 p.m. (RL-Mass.)

LK? on 9610 kcs. in Oslo is heard daily from 1-5 p.m. (RL-Mass.) This station operates in parallel with LKG on 9530 kcs.

#### Panama

HP5A on 11700 kcs. at Panama City broadcasts news in English at 6:30 p.m. (R7-Pa.1)

#### Paraguay

ZP14 on 11720 kcs. at Villa Rica operates on the following schedule. 7:07 p.m. to 9:07 p.m. Their slogan is "Radio Cultura." (R211-T.H.2)

#### Peru

OAX1A at Chiclayo lists its frequency as 6150 kcs. instead of 6335 kcs. They broadcast from 7:30-11:30 p.m. and their address is Radio Delcar, OAX1A, Saenz Pera No. 109, Casilla No. 9, Chiclayo, Peru. (R21-Pa.3)

#### Portugal

CS2WD on 11740 kcs. is heard on Tuesdays, Thursdays, and Saturdays from 2-3 p.m. (RL-Mass.)

#### Siam

HS6PJ on 19020 kcs., Bangkok, has been heard on Monday mornings after 8 a.m., but no signal has been picked up on 19 meters. (Skyten-Mass.)

#### Sweden

SBO on 6065 kcs. in Motala, is heard occasionally in the evenings. I

heard them the other day at 4:30 p.m. coming in between W8XAL and CFRX with strong signal. (Skyten-Mass.)

#### Switzerland

HBO on 11402 kcs. was heard from 3:15 p.m. till 3:30 a.m. broadcasting news of the League of Nations. It was stated in their broadcast that they would be on again next Sunday at 3 p.m. on HBO and HBQ on 6675 kcs. (R574-Me.)

#### Turkey

TAP on 9465 kcs., "Radio Ankara" according to January RADEX operates from 3-5 p.m. However, I find that they are now heard from 1:30 p.m. until 5 p.m. On Dec. 24th, and Dec. 31st, they were heard from 2:30-5 p.m. On Jan. 1st they were on from 2:15 to 4 p.m. I believe the schedule to be from 1:30-5 p.m. daily including Saturday and until 4 p.m. on Sunday. The signals are usually weak at the start of the broadcast, but gradually strengthen throughout the transmission. At 4 p.m., they are QRM'd by CW. (In fact they are almost completely obliterated—RL.) (Leshner-Mass.)

TAQ on 15190 kcs. is used for morning transmissions and TAP on 9465 kcs. is used for evening transmissions—Turkish Time! (Leshner-Mass.)

#### Uruguay

CXA-6 on 9620 kcs. until 9 p.m. experimenting. (RL-Mass.)

CXA-8 at Colonia, now signs off between 10:45 and 11:00 p.m. but they have not changed their transcription yet. Saturday programs end at 1 a.m. (R211-T.H.2)

#### Union of South Africa

ZRK on 9606 kcs., can be heard

every night from 11:45 p.m. to 12:45 a.m. Program consists of two series of setting up exercises and news with chimes striking the hour of seven in South Africa at midnight here. (Hoover-Penna.)

ZRK on 6097 kcs. is heard very well in the afternoon from 3-4. (RL-Mass.)

#### U.S.A.

W2XAF on 9530 kcs. has been granted permission to use two additional frequencies, namely; 6190 kcs. and 21590 kcs. (RX)

W4XB on 6040 kcs. is now keeping somewhat of a regular schedule and is asking for reports from listeners. They relay the programs of broadcast station WIOD on 610 kcs. The transmitter is located at Miami, Fla. (Bonnell-Ohio)

W6XBE on 15330 kcs., and 9530 kcs. with 20000 watts power will go on the air with a 24 hour service on February 18, the day of the opening of the 1939 Golden Gate Exposition.



"The Voice of the New York Fire Department," WNYF 1630 kcs. WNYF is located in the Queens, but controlled from Central Park in Manhattan; it works with fire boats in New York Harbor, all of which transmit on the ultra high frequencies. (Courtesy of Francis Coradetti).

Broadcasts will take place on Treasure Island at the fair with transmitter at Belmont, Calif. (Bonnell-Ohio) W6XBE has been granted the use of 6190 kcs. in addition to the above. (RX)

**U.S.S.R.**

RV-96 on 15270 kcs. heard very irregularly around 9 p.m. (RL-Mass.)

Radio Center, at Moscow announces a new policy. No longer will it be possible for DXers to obtain a verification from this country on a program in any language other than the language used by the reporter in writing to the station. This leaves but two alternatives to DXers. Either learn to report in the Soviet language or report only on English programs. The English programs from Moscow are:

- 19.76 meters Daily at 3 a.m.
- 25.00 " Sun. at 5 and 10 a.m.
- 50.00 " Wed. 6:30 a.m. and Sun., Mon., Thurs., Fri., at 4 p.m. and Sat. at 5 p.m.
- 31.25 " Daily at 7 p.m.
- 19.89 " Daily at 7 p.m.

(R184-5-Minn.)

**Vatican City**

HVJ on 11740 kcs. heard recently for the first time just five minutes previous to sign off. The time at which they signed was 1:45 p.m. Actual schedule on this frequency will be appreciated by (Leshner-Mass.)

**Venezuela**

YV5RM on 5010 kcs. can be heard broadcasting nightly after being listed for many months. (RL-Mass.)

**Yugoslavia**

YUA on 6100 kcs. at Belgrade, "Radio Beograd", was heard as early as 8 p.m. on Dec. 31. There was no QRM and signal was R7-8. (Skyten-Mass.)

**AMATEUR RADIO LICENSES**

Day and Evening Classes in Code and Theory

**HOME STUDY COURSES**

*Reasonable, Efficient and Thorough, Hundreds of Licensed Students*

*Now on the Air*

**AMERICAN RADIO INSTITUTE**

1125 Broadway

New York, N. Y.

YUA on 6100 kcs. heard coming on the air at 12:42 a.m. with repeated flute notes, then National Anthem and at exactly 12:45 one stroke of the gong sounded followed by news till 1 a.m. At one a musical program which lasted until 2:10 when the station signed off the air. (Bartholomew-Mass.)

**India (Additional)**

VUB-2 on 2905 kcs. is heard best (in Hawaii) from 12:-12:30 p.m. with programs of dance music relayed from Bombay hotels. Signal is R9, but QRM from closed CW xmr. cuts it to a QSA-3. (R211-T.H.2)

**The Reporters**

- RA: A. I. Breen, Dunedin, New Zealand.
- RG: Harry Gordon, Erie, Penna.
- RL: Ray La Rocque, Worcester, Mass.
- RX: Official.
- R7, Pa. 1: A. M. Hankins, Latrobe, Penna.
- R16, Mass. 1: Charles Leboeuf, Webster, Mass.
- R21, Pa. 3: Ed Lang, Philadelphia, Penna.
- R184-5: Carl and Anne Eder, Willmar, Minn.
- R211, T.H.2: C. J. Fern, Lihue, Hawaii.
- R451: Chester Roman, Chicago, Ill.
- R473: John Macrea, Winnipeg, Manitoba, Canada
- R545: Stanley Fairchild, Toronto, Ohio.
- R574: Philip Craig, Waterville, Me.
- R591: Caribbean Listening Post, Catana, P.R.
- R651: Robert F. Wolfskill, W9XA, Kansas City, Mo.
- R671: Robert Trubee, Brantwood, N. J.
- Al Bartholomew, Bradford, N. Y.
- Al Bettinger, Omaha, Nebr.
- Bertram Podall, Gilman, Vermont.
- Walter R. Bonnell, Jr., Cincinnati, Ohio.
- Forest W. Fisher, Battle Creek, Mich.
- David Hill, Washington, D. C.
- Bob Hoover, Wilkes-Barre, Penna.
- Matthew E. Leshner, Lawrence, Mass.
- Richard K. Neller, Niagara Falls, N. Y.
- Richard Ritzenheim, Grosse Pointe Farm, Mich.
- Robert Skyten, East Brookfield, Mass.
- Pat Webb, San Antonio, Texas.

NOTE: Please be sure always to sign your Radex Club indica to every letter or report you write.

**SHORTWAVE SCOOP BOX**

CR6RC on 11740 kcs has been definitely identified to be located in Loanda, Angola (Portuguese West Africa).

IABA on 9650 kcs. in Addis Ababa, Ethiopia, is heard signing off at 3 pm.

12RO-10 on 15100 kcs. is heard daily from 3-4 pm.

YV1RN on 4860 kcs., "Radio Popular," is now broadcasting, evidently replacing YV1RK and YV1RL.

All the Scoop Box Reports are by RL—Mass.

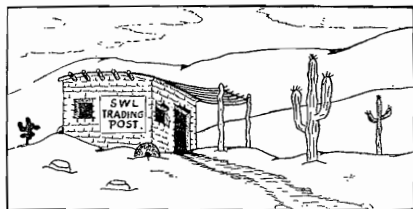

Clarence O. Schwengel, 123 N. Bedford St., Madison Wis. (SWL cards).

Evan B. Roberts, Wenham St., Danvers, Mass. (BCB DXers who hear foreign stations—correspondence).

F. J. Slosson, Box 808, Dryden, Wash. (SWL cards).

J. T. Lippincott, E. Vassalboro, Maine. (SWL cards—will send his triple card showing views of Tufts College).

Don Sollenberger, 117 So. Grevillea Ave., Ingewood, Calif. (Correspondence).

Robert G. Rowe, Hotel Yardbrough, Huntsville, Aa. (SWL cards).

Howard G. Bardin, 29 Tredeau St., Hartford, Conn. (Correspondence with nearby fans).

Howard F. Dixon, 23 Guelph St., Stratford, Ont., Canada (SWL cards).

Ronald C. Wellstood, 288 Egan Ave., Verdun, P. Q., Canada (Correspondence).

J. I. Vaught, Box 1424, New Orleans, La. (SWL cards).

Merlin N. Steen, Route 6, Decorah, Iowa (SWL cards and photos).

E. A. Clayton, Tinana, Maryborough,

Qsld., Australia (Newspapers; Canada, U.S.A. and British Colony stamps).

M. A. Adkins, 19 Nanticoke Ave., Union, N. Y. (SWL cards).

**Questions and Answers****Using Crystals**

*J. P. L., Woodbridge, N. J. I own a Hallicrafter Sky Challenger. Is it a good set for foreign broadcast reception? Would a crystal help on the broadcast band?*

*Answer.* This set should be capable of picking up foreign stations on its broadcast band provided the stations have sufficient power and use wavelengths within the set's range. Foreign stations on this band do not come in so well, since it takes a great amount of power to cover the distance—much more power than is required on the short waves. A crystal might help a bit in making tuning sharper on the broadcast band, but we do not think it will provide any unusual performance. The crystal is best on the congested short waves.

*A. W. L., Sioux City, Iowa. The two local broadcasting stations interfere and are heard all over my 7-tube Zenith. Why is this?*

*Answer.* It appears that your set is badly in need of adjusting, cleaning and aligning. A good service man should be consulted. If the set tunes too broadly, these two stations with a frequency difference of only 90 kilocycles between them, might cause a heterodyne beat note. If readjusting your set to make it tune sharper does not improve the condition, we suggest a good wave trap set against the one station not desired.

# When RADIO SETS See SPOTS

By B. FRANCIS DASHIELL

---

**Among the most frequent and perplexing of all the troubles that are inflicted upon DXers' receivers, are images, double-spots and harmonics. In this story, Turner Dial, expert service-man, explains these troubles, and suggests a few antidotes.**

---

● In spite of the icy streets and cold weather that interfered with most of the town's business, the service department at Higrade Sales and Service had been unusually busy. "This long cold wave has made it fine for radio reception," declared Turner Dial, as he sat down at his desk and leaned far back in his chair. "People have been anxious to keep their receivers in tip-top condition."

"Yep," answered Bill Wood, who was cleaning up around the big service bench. Bill, who was Turner's young assistant, had been engaged in old radio repair jobs all day. "Yep, we've been busy. But they were small jobs, and nothing out of the ordinary. Just parts that gave out."

"I've been thinking about that for some time," commented Dial, "and, from what I can figure out, most radio troubles come from condensers. We replace more condensers than any other part. Then, too, much trouble comes from bad resistors. Condensers and resistances—those are the two things that are likely to go bad in a radio."

"Isn't that natural?" asked Bill Wood. "Seems to me that even the best condensers and resistors are delicate, and they take a lot of strain from the high electrical voltages going through 'em. They can't last forever. What else gives the most trouble?"



"Well," answered Turner, "I should say the windings of coils. They break, burn out, corrode from moisture, and short circuit. Usually these are the field windings of loud speakers, audio transformers and choke or filter coils. They are large windings on heavy iron cores. Volume controls cause considerable grief!" Turner glanced up at the clock on the wall. "It'll soon be closing time. Think I'll relax a bit." And Turner stretched out by resting his feet on the desk before him.

"But," continued Bill, "what about the other parts of a radio? There are other coils that can go bad."

"Of course they do," replied Dial in a lazy tone, as he yawned. "But the air-core type of coils, such as radio and intermediate-frequency transformers and loud speaker voice

coils, don't give trouble so often. That's because they don't have such large windings or carry a high current. And power transformers are pretty rugged. They give the least trouble of all!"

Bill Wood munched thoughtfully on a candy bar. "Say! that's a good hint," he declared. "A set should be checked first for condensers, then resistors, and then the large coil windings. Finally look at the r.f., i.f., and power transformers. That ought to give you a line on the trouble!"

"Sure," mumbled Turner. "That's what we've been doing for years!"

At that moment the sound of voices at the entrance of the store aroused Dial to action. He arose from his chair, but, quickly recognizing three young men who were frequent visitors to the shop, he settled back again. "Hello!" he called to these DX fans, "come back here where its nice and warm. Say, what's that you're bringing in?" This remark was addressed to one of the trio who carried a table model in his arms.

"My radio," answered the young man. "I need some help!" He deposited the set on the bench and raised himself between the radio and Bill Wood, feet swinging in the air. After a few minutes of radio chatter and some idle bantering with Bill, the owner of the radio finally got Turner Dial's attention. "Why is it," he demanded, "when radio engineers are working so hard to create new ideas to sell receivers, they don't try to correct some of the faults that keep on giving trouble?"

Turner gazed thoughtfully at the speaker. "What's on your mind?"

he asked.

The young man placed his hand on the radio beside him. "This set," he began, "has image frequencies or double spots, or whatever you call 'em, and I'm about fed up with it all. Why haven't they done something about this trouble? Do new sets have the same thing too?"

"Hey! One thing at a time!" was Turner's response. "You're getting on complicated ground. That sort of trouble isn't a simple thing."

A perplexed look passed over the listener's faace. He glanced at the two friends who accompanied him, and they nodded in return. "In that case," said one of them, "maybe Turner can't do anything about it."

"Oh, maybe I can," was Dial's comment. "But let's see how this set behaves. Tell me about it or give me some good example."

"Sure!" he said. "That's easy! When I tune to our local station, I always get police calls, if they are being sent out. The interference is bad, and I can also hear other stations off their settings at the same time I'm listening to certain stations which are on their proper dial numbers."

"Whew!" whistled Turner. "You would bring up one of the toughest questions in radio!" Swinging around, he glanced up at the clock. "Lock up, Bill!" he directed. "Then we can talk without interruption." Dial leaned back in his chair, filled his pipe, and blew a floating ring of smoke. "In some sets," he began, "there isn't much that can be done about image frequency and double spots. While these things are very much the same, they are quite differ-

ent in their effects. However, when one is present in a set, the other will be there too."

Bill Wood returned to the rear of the store after locking the front door and snapping off the brightest lights. Overhearing Turner's remarks, he asked: "Why is that?"

Turner smiled. "Well, you see, image frequency means that a station shows up when you are listening to another station. This undesired station will be far from its correct dial position. Therefore, while you are listening to the station that is properly tuned in, you also get an 'image' or 'reflection' of the second or unwanted station. This causes interference, and usually makes both stations sound more or less unintelligible. So, that's why you can hear the police station along with the local broadcasting station, although you are not tuned to the police band. This problem occurs just because two stations happen to have frequencies that bear a mathematical relationship to the intermediate frequency that is used in your own receiver."

"But what about double-spot tuning?" another of the trio asked.

"As a matter of fact," continued Turner, "they are just about the same thing. The term 'double spot' means that a receiver brings in the same station twice, but on two different dial readings. One position will be the proper setting in kilocycles, but the other will be spaced some distance away. There may be no interference unless the off-position falls upon the correct dial reading for another station."

Turner arose and began to examine

the receiver. It was a popular 1937 model set using six tubes. He noticed at once there was no radio-frequency stage. There was a combined first-detector and oscillator; one intermediate-frequency stage; a second detector and a. v. c.; a first-audio stage; and an output power tube. "That's a good set," commented Turner, "but not all that is to be desired. Maybe it can be helped a bit." He reached for a binder of service bulletins and turned the pages. "It uses an intermediate frequency of 456 kilocycles. That makes it easier for us. Older sets with a lower i. f., such as 175 kilocycles, often gave a lot of this trouble. They couldn't be cured of seeing double!"

Dial took his pencil. "Let's see," he asked, "what local station do you listen to when you also hear the police at the same time?"

"It's a station on 770 kilocycles," was the reply. "And there are some other cases, too, between 550 and about 800 kilocycles, when I can hear interfering stations. Three or four cases, I guess."

"Humph!" grunted Dial, as he jotted down some figures. "Now all of you remember this little fact," he said. "The oscillator tube of a superheterodyne set operates at a frequency that is higher than the incoming signal frequency to which the set is tuned. So, in your case, the oscillator always is generating 456 kilocycles more than any signal that is being received. Now, when you tune to 770 kilocycles, this means that the circuit is oscillating at 770 plus 456, or 1226 kilocycles. If we figure backwards we will find this to be correct. For, if an oscillator mixes its 1226 kilocycles with an incoming signal of 770 kilo-

cycles, it produces a beat note of 456 kilocycles. This frequency then passes easily through the i. f. stages of your set, for they are tuned exactly to 456 kilocycles. That's the fundamental principle of the superheterodyne circuit."

Turner figured again. "But," he added, "suppose there is another signal in existence, and it is strong enough to creep through the tuning circuit and get into the oscillator and first-detector tube. If this signal happens to be approximately 456 kilocycles higher than the 1226 kilocycles at which your oscillator is working, it might push into the intermediate-frequency stages and cause interference. So, let's add 456 to 1226. This gives us 1682 kilocycles. You'll notice that's at the far end of the high-frequency portion of the broadcast band. Most of the newer sets tune up to about 1700 kilocycles on that dial. This brings in some police calls. I'm certain you'll find a police station close to 1682 kilocycles, as that's a police band. This station should be the one whose image you hear when tuned to 770 kilocycles. Remember this, any station that appears as an image will have an operating frequency that is equal to twice the i. f. of your set plus the frequency of the station to which you are tuned. Or, in other words, the difference between the two stations on the dial is simply twice the intermediate frequency of the receiver. Take your station at 770 kilocycles, for instance. Now add to that number twice 456, or 912, and you get 1682. Or, set the dial on 770. Then move 912 kilocycles along the scale. You again get 1682. Tune

to about 1682, or say 1680, and you'll find that is the correct position of the police station that has its image at 770 on the dial. Get me?"

"Yep!" exclaimed the group as one man. "That's also an easy way of locating the proper setting of some unknown station that is interfering as an 'image' with the desired station," remarked one of the young visitors.

"What about those double spots?" demanded Bill. "We'd like to know why a radio sees double!"

"It's the same thing again," answered Turner. "Only you tune in one station at some additional point on the dial. Since your set reflects unwanted images, it also can show double spots on the dial. We get double spots at the lower end of a dial when the real setting for a station is at the high-frequency end. Let's go back to our police station. If we hear it at 1680 kilocycles, then we can get its double at a point that is lower by twice the i. f. of the set. In other words, take 1680 and subtract twice 456, or 912, and you get 770. Double-spot reception, therefore, will appear at 770 kilocycles. Now, if some station is operating there, you will also get interference. So, it all boils down to this: If you are listening to 770 kilocycles, and a station at 1680 comes in as interference, you call it 'image-frequency' interference. But if no station is operating at 770, and you are tuning around the band and pick up a station at 770, and you find out from its call letters, later on, that it is actually a station at 1680 kilocycles, you call it 'double-spot' reception, and get pretty peeved about it."

"Say! I've had that happen several



times," commented one young man. "Since they are so closely related, it depends mostly on how you are tuning, as to whether you call it an 'image' or a 'double'!"

"That's right," answered Turner Dial. "But don't forget this: Double spots can appear anywhere on the dial, just so their separation, which is twice the intermediate frequency of the set, does not throw one point entirely off the dial. That's why the use of high intermediate frequencies prevents much of this trouble. If a set has several bands, which, after all, are only a continuation of the broadcast band, then the double spots from strong station may appear on different bands. For instance, a station at 2400 kilocycles, on the medium short-wave band, might be heard also as a double spot at 1488, or 1490, which is on the broadcast band. Or the station at 2400 on the medium band might cause interference at 1490 on the broadcast band. Then this is image-frequency interference. Then there are harmonics of stations which cause images. The second harmonic of the oscillator in this set, when tuned to 770 kilocycles, will be twice 1226, or 2452 kilocycles. If a strong code signal of 2900 kilocycles from the medium band enters the receiver and works with the oscillator's second harmonic of 2452 kilocycles, it will be heard at 770 kilocycles. This is the image of 2900, and accounts for the fact that we hear code sometimes at different places on the broadcast dial. It all can be figured out by simple arithmetic."

"I understand all that now," said the owner of the set. "But what about the cure?"

"With some sets," said Turner sad-

ly, "there's no such thing as a real cure. However, good sets, large sets, now take care of this trouble automatically. It just doesn't exist. Smaller sets can be helped in certain ways. Now, a set, if it has a good radio-frequency stage and tuning system, which is known as a pre-selector, will tune out strong unwanted signals. Your set, here, unfortunately, has no radio-frequency stage, and therefore does not tune as sharply against strong near-by signals. But with a good tuning circuit, the signals can't get into the mixer and oscillator tube and cause the kind of trouble we have been talking about."

"If a man buys a set that doesn't have a sharp antenna tuning circuit, it's apt to develop double spots and images, and he is 'stuck' with a bum set. What can he do?" inquired Wood.

Dial glanced at the clock. "Receivers that don't have preselection circuits built into them, if they show a tendency toward this trouble, may be helped by adding a radio-frequency stage in the form of a separate unit. This arrangement often eliminates all such trouble, and gives a greater range and stronger signals. These units are known as 'pre-selectors.' Then, too, a simple 'wave trap,' set against any station that creates an image at some point on the dial where you wish to hear some other station, usually will clear up the image interference. Other than a careful overhauling, there isn't much more that can be done for old and small sets which might be defective or have insufficient tuning circuits ahead of the mixer tube. These sets fail to reject some of the most powerful and nearby stations."

*(Please turn to page 95)*

## ACROSS the Editor's DESK

● The headlines in the news have been of more than usual interest to DXers lately. Highlighting the radio news, are announcements that a facsimile receiver, employing the Finch system, has been placed on the market; that the General Electric Company will soon commence broadcasts over the most high powered television station in the United States; and that regular broadcasts will be inaugurated from W2XMN, forty kilowatt staticless radio station at Alpine, New Jersey.

The new facsimile receiver, named "Reado," manufactured in Cincinnati, has been demonstrated with immense success in that city and in New York. Priced at less than a hundred dollars, the new receiver has already been placed on the market. Listeners in the New York area will have available two facsimile broadcasts daily from WOR, one of these broadcasts being the regular early morning transmission on 710 kilocycles, and the other taking place in the afternoons, from 2 to 4 p. m., over station W2XUP, WOR's station on 25700 kilocycles. Mr. Finch's own transmitter will also be on the air within a few months, serving New York listeners. Finch facsimile broadcasts are already available, or will soon be available, in many cities throughout the country.

The General Electric ten kilowatt television station will be situated high in the Belderberg Mountains, serving the cities of Schenectady, Albany, Troy and Amsterdam. The studios will be in the old WGY studios in Schenectady. Instead of employing the usual coaxial cable as a transmission line to connect studio and transmitter, G-E



*This Guatemalan card illustrates the quetzal in natural colors, green, brown and red. The quetzal is a beautiful tropical bird that almost invariably perishes when kept in captivity, so the Guatemaltecos have adopted it as a suitable symbol of freedom. (Courtesy of Rick Anderson and A. D. Jordan).*

will employ an ultra-shortwave transmitter at the studio to send the programs to the transmitter. The frequency band to be employed will be the 66000 to 72000 kilocycle channel.

● The Havana Conference, already ratified by the United States, Canada and Cuba, is travelling a very rocky road in Mexico. This agreement, calling for a revision of the frequencies of the radio stations in United States, Canada, Cuba, Mexico, Newfoundland, and the Dominican Republic, will become law one year after its ratification by the four major coun-

tries. The Mexican Senate, in secret session, refused to sign, and it was felt at the time that the Mexican border stations, which would be greatly affected, were at least partly responsible for the decision of the Senate.

Following the Senate's refusal to ratify, the Mexican Ministry of Communications took the situation in hand, and it was generally felt that the agreement would be adopted. Then President Cardenas changed his Cabinet, and the Minister of Communications lost his job. Maybe his successor will like the treaty. We hope so. Meanwhile, we have other troubles.

Cuba, the first country to sign the treaty, has already switched her stations up and down the dial, and this has not helped our stations at all. Cuba made her reallocation about a year too soon, and as a result we are going to have to make some changes, or give some stations temporary increases in power (as has already been done), or send a delegation to Cuba and ask them to put their stations back where they were until the treaty becomes law.

● Back in 1905 a young musician was so impressed by the fact that the language of music is universal, that he decided to develop a language based on music. The result is the Spatari Radio Language, an ingenious system of speech based on the notes of the musical scale, capable of being understood by anyone, regardless of his native language, and requiring no study of **grammar, vocabulary or syntax.**

The entire language consists of only the seven notes DO, RE, MI, FA, SO, LA, and SI, and the symbol BO. Capable of being combined into nearly a million different words or groups, these symbols can be pronounced on sight, and easily written down as soon as heard. The "secret" of the language is that each group of symbols represents an entire thought, or sentence. It is not intended that anyone memorize the symbols, as they can be written down as heard, and found quickly in the Spatari dictionary later.

The inventor of this language, Professor Carlo Spatari, an Honorary Member of The Radex Club, has assigned the symbol SIFABOBO to The Radex Club.

Many radio stations broadcast DX tips in the Spatari language; a list of the stations will be found in the DX Calendar appearing in RADEX each month.

● The largest city in the United States without a broadcasting station, is Paterson, New Jersey.

The smallest city in the United States without a radio station, is Kilgore, Texas.

#### **XEBW Special**

Station XEBW, Chihuahua, Chih., on 1340 kcs., will broadcast a program for the URDXC on March 2 from 4 to 5 a.m., E.S.T.

# This and That in the DX World

●●● By CARLETON LORD

● Preparation of this section for the March RADEX is usually one of the most interesting of all activities connected with the magazine. As this is written, on February 2nd, the current DX season has reached its peak, and devotees have been able to judge whether the winter has brought its share of DX success.

It is at about this time of year that reports from readers give the first true indication of how reception conditions have been. The fall season for Aussies has come and gone, the mid-winter months of European and South American reception are about over, and only the spring season for Aussies lies ahead.

This year, it is with particular interest that reports are scanned and observations noted. Only a few short months ago, at the opening of the fall season, it was predicted that an unusually good DX winter lay ahead. With a decrease in sunspot activity, it was felt that conditions for long distance reception would be particularly favorable, and it was forecast that broadcast band listeners would enjoy a season reminiscent of the "good old days" of 1932-35.

Early-season reports seemed to indicate that the prognostication was not in error, but it was necessary to wait until the time of writing before any definite analysis could be made. And so it is that the reports received during January are of particular interest.

For the most part, the latest batch of letters appear to indicate that the season to date has been above the average of the past three or four years.

True, there are isolated cases of DXers who have not been able to boast of outstanding additions to their logs, listeners who have found static heavy and signal strength below expectations, but they would seem to be the exception rather than the rule. The majority seem to agree that the season has been very much worthwhile.

Reception of stations from all parts of the North American continent is indicated in most reports. Even DXers on the two coasts advise that trans-continental reception of 100-wattors once more is an everyday occurrence, rather than an occasional highlight of a month's listening.

But what is most surprising of all, is an indication that transoceanic reception has come back with a vengeance. Not just a scattered handful of TA's, TP's and SA's for the patient dial twister, but a veritable landslide of foreign signals, which have been bursting through the domestic line-up and almost begging to be heard! Stations, large and small, from all parts of Europe, South America and the Antipodes, have been coming across the seas to knock on aeriels all over the country.

The only thing which mars such a pleasant situation is the fact that too few listeners have been taking advantage of this unusual reception. Whether DXers have become accustomed to sticking to strictly domestic stuff and simply don't try for foreign catches, or whether conditions for the past few years have been such that they don't recognize a trans-oceanic station when they hear it, it is hard

to say, but the fact remains that only a comparative few listeners have made the most of an unusual season.

On the surface, such a situation might indicate that the favorable conditions had not been general throughout the country. However, the listeners who have gone to town with the foreigners have been scattered all over the continent, and the magnitude of their reports makes it appear certain that a great many DXers have missed out on something good.



*Canadian station CKCH, Hull, Quebec, verifies with this card. It is printed in black, with the large letters "DX" in red, and embossed with the station's seal. (Courtesy of F. T. Coradetti).*

#### News of the Stations

Four new United States stations came on the air during the past month to add to the confusion on the broadcast band. WSTP, 1500 kcys, Salisbury, N. C., made initial tests towards the end of December, and was on a regular schedule shortly afterwards. KVNU, 1200 kcys, Logan, Utah, made equipment tests during January and was reported by many listeners. January 15th was opening date for two stations—KTSW, 1370 kcys, Emporia, Kans., and WCOV, 1210 kcys, Montgomery, Ala.

According to word from WTMA,

1210 kcys, Charleston, S. C., its first test broadcast will take place at 2 a.m., EST, on March 15th, and reports are that WMFJ, 1420 kcys, Youngstown, Ohio, will hit the air in the very near future. WGNV, Newburgh, N. Y., is reported changing its frequency from 1210 to 1200, boosting its power to 250 watts, and going on a time-sharing schedule with WFAS and WBRB.

Down in Mexico, the night-owlish XEPN was destroyed by fire and its 730 channel promptly occupied by XELO, late of 670, late of 580. A new station at Chihuahua, Chin., XEM on 1390 kcys, opened early in January and was promptly reported by a bevy of listeners.

A key to the confusion caused by the Spanish-speaking stations was provided by the National Radio Club with a list of the Mexicans, and their frequencies, most frequently reported by members: 710—XEQ; 730—XEPN; 750—XEAA; 820—XEBG; 840—XERA; 860—XEMO; 890—XEW; 910—XENT; 930—XEBH; 945—XEFO; 960—XEAW; 980—XEAC; 985—XEFE; 1030—XEB; 1080—XEDP; 1090—XERB; 1150—XEL; 1160—XEP, XED; 1120—XEDA, 1240—XEAI; 1340—XEFC; 1390—XEM; 1440—XEFI; and 1460—XEQK. The more frequently heard Cubans and Central and South Americans, added to that list, will give dialers a pretty accurate check on the Spanish-speaking stations heard during the evening.

A new station is reported on the air in New Zealand—2YH, 760 kcys, 5 KW, Hastings. And in Australia, 6WN at Perth, 790 kcys, is at

last in operation with power unknown. Incidentally, chances to add to the log of Aussies is increased with power boosts to 10 KW for 3LO and 2FC.

The Japanese correspondent of the UDXC advises of several new Japs now on the air: JBKD, 1080 kcys, 250 watts, Kanko, Chosen; JBFK, 570 kcys, 500 watts, Riri, Chosen; JOSG, 880 kcys, 500 watts, Morioka; and JORG, 840 kcys, 300 watts, Hiroasaki.

"Station WGAN is now on the air from 6:30 a.m., EST, until three hours after local sunset," advises Earl McDonald, Portland, Me. "The station uses a 350-foot vertical radiator and a twin 350-foot reflector. The signal is suppressed in the direction of Providence, R. I., and Columbus, Ohio."

"Station WSAJ operates from 7:15 to 8:45 p.m. on Tuesday and Thursday, and from 4:30 to 5:30 p.m. on Sunday," contributes Fred L. Voorhees, Grove City, Pa. "Special broadcasts of college activities are made with special authority."

"Several weeks ago, during a DX broadcast from XERA," pens R. E. Simon, Kirkwood, Mo., "it was announced that their power was 520 kilowatts, as compared with your listing of 250 KW, which makes them the most powerful station in the world. Their chief engineer, the second engineer and several other station officials described their equipment."

"Station WWL is now using its new 50-KW transmitter," contributes Pat Webb, San Antonio, Tex. "Recently, I heard WILL testing its new

5-KW equipment. XERB, Rosarito Beach, B. Cfa., is back on the air on 1090, and can be heard in the clear from the time KMOX signs off at 12:30 a.m., CST, until 2 a.m."

"There is a new Korean BCB station which should be heard in the United States," writes C. J. Fern, Jr., Lihue, Hawaii. "It is JBCK, a 10-kilowatt at Seishin, on 850 kcys."

#### Tips and Specials

Listeners desiring to verify KERN are reminded that the station signs off at 3 a.m., EST, at which time it is possible to get data for confirmations. After KERN goes off, KRE can be heard and, even in the case of Atlantic Coast DXers, it should be a comparatively easy catch. Another West Coaster, KDON at Monterey, Calif., has been heard frequently at its 2:30 a.m., EST, sign-off.

CHSJ, 1120 kcys, St. John, N.B., can be logged at 5 a.m., EST, daily, when it comes on for a few minutes with weather reports for Maritime fishermen. Another Canadian, CJRC, 630 kcys, Winnipeg, Man., has been heard lately on Sunday mornings, broadcasting until 3 a.m., EST.

DXers needing a Wyoming station to complete their roster of states, should have no trouble hearing KDFN at Casper, 1440 kcys, on its commercial monitoring broadcasting from 3 to 3:15 a.m., EST, on the first Friday of each month.

Additions to the FCC monitoring schedule include three of the most recent stations to take the air, as well as one change. On the second Wednesday, WKST, 1250 kcys, New Castle, Pa., broadcasts from 4:25 to 4:40 a.m., EST. On the second Saturday, there are three stations to be added to

the list appearing in the February RADEX: 3:55-4:10 a.m., EST, KSAM, 1500 kcys, Huntsville, Tex.; 4:15 to 4:30 a.m., EST, KIUN, 1370, Pecos, Texas; and 5:25 to 5:40 a.m., EST, WSTP, 1500 kcys, Salisbury, N. C.

Of special interest to all DXers are two special courtesy programs on tap for the month of March. On the 11th, XEBO, 1310 kcys, Irapuato, Guan., will broadcast from 3 to 4 a.m., EST, for the NNRC. And on the 22nd, the IDA sponsors a program from YSS, 640 kcys, San Salvador, from 1 to 2 a.m., EST. Just how the station will break through KFI at that time is hard to understand, but it'll be worth a try.

For last-minute news on special programs, the tip periods from some of the more friendly stations afford a world of information for the DXer. Some of these broadcasts are sponsored by individual radio clubs, while others are run by the stations for all clubs and listeners, but all are prolific sources of timely tips.

Although a complete schedule of these broadcasts is not available, following are a few which are worthy of attention: KLS, every Friday from 2 to 2:15 a.m., EST; KSL—every Thursday from 2:45 to 3 a.m., EST; KOY—every Wednesday at 12:30 a.m., EST; WTAR—every Wednesday from 1:45 to 2 p.m., EST; WEEU—every Saturday at 10:30 a.m., EST; WJBO—the first and third Sundays from 3 to 4 a.m., EST; and WPAY—the first day of each month, from 4 to 4:30 a.m., EST.

The Newark News Radio Club's broadcasts over WOR's experimental W2XJI, 26.3 mgs., formerly heard

on Tuesday and Friday nights, are now scheduled for 5 p.m., EST, every Saturday. DXers who can tune this ultra high frequency station, are assured of an interesting program of last-minute tips, talks on various phases of DXing by prominent club officials, and timely discussions of DX problems.

#### Radexers Report

"Here is a resume of my record since November 15th, when I first started to DX," offers Frank B. Lee, Wildwood, N. J. "Using a 23-tube Scott receiver, I have logged 421 stations from every state except Wyoming and Nevada. Outside of the United States, I have heard Stuttgart, Lyons, Cologne, Paris (695 kcys), Toulouse (both on 776 and 913), Leipzig, Cardiff, Bordeaux and Radio Normandie, as well as stations in Canada, Costa Rica, Cuba, the Bahamas, Guatamala, Mexico, Argentina and Puerto Rico. Signals of European stations range from R3 to R6 between 4:45 and 7 p.m., EST, while between 1 and 3 a.m., they sometimes get as high as R8."

"DX has showed considerable improvement over last season," comments J. W. Brauner, Williamsville, N. Y. "The TP's have been better than anytime in four years, and two new South Americans have been added to the log. The 100 watt stations on the Pacific Coast have been showing up nicely. KARM has bested WEXL several times recently on 1310 kcys. On 1420, home of the newest 24-hour station, WBNO, KORE and KSAN have been taking turns at riding in over the top of the Louisiana station."

"Some of the BCB DXers in this

country have crazy notions," asserts Jack Siringer, Cleveland, Ohio. "According to them, all the Spanish-speaking stations are either Cubans or Mexicans. For instance, the other morning LS11 was so strong between 1 and 2 a.m. that I still had 'em R9 after disconnecting the aerial, yet no one has reported hearing them. Incidentally, I picked up a honey of a catch recently—CX18 on 890 kcys, with but 1500 watts according to your listing."

The general thought behind Reader Siringer's remarks was elaborated more or less in detail earlier in this section. For some unknown reason, American listeners have fallen into the habit of watching out for only domestic stations. Apparently they are so intent on listening for Walla Walla or Kalamazoo, that they brush right by numerous foreign stations. South and Central American signals are ignored as Cubans and Mexicans, French stations are dismissed as French-Canadians, and so on. The title of this section last month, "DX Is Where You Find It," seems rather opportune, as many DXers wouldn't recognize a nice foreign catch if it was dropped in their lap.

"The broadcast band has been fair so far," remarks M. A. Adkins, Union, N. Y. "My best catches to date include KGBU, KSEI, CJAT, KFEL, KVOD, CHN S, KOIN, KJR, CMQ, CMKL, CMCP, CMHI, CMHA, HIN, KOB, KEX, KTMS, KYA, KFOX, KIT, KPAC, KDYL, KTRH, KALE, KARM, KMO, KGER, KGA, KFBK, CMBF, KPMC and CMBH. Most of these were received with a good signal strength and were consistent during reception, but I must

admit that it took a great deal of patience to pull them in."

"Since moving to this new location on October 1st," relates Carl E. Sylvester, Columbiaville, Mich., "I have found conditions very good. Even with a 10-foot antenna, the Zenith 6S229 is pulling in stations from Chicago and most of the nearby states. I heard CMQ on 1010 kcys, as well as several stations on the 1500-1600 experimental band. KOB on 1180 has been heard R7-8 several evenings when they were beginning their newscasts."

"This morning, January 9th, we got up at 3:10 a.m. for some DX on 20 meters," informs Philip L. Craig, Waterville, Me., "but instead we DXed on the broadcast band—and were we surprised! Of course, the first stations were KNX, KOA and KFI. These were followed by CJCA, KFVD, KSAC, WTOC, KWSC and KVOA, all with power of 1000 watts. At this time KWSC was broadcasting a special DX program, but this was not known until 5:58 a.m., and they signed off at 6:03."

#### Replies to Queries

One of the greatest services performed by Radexers is the answering of questions put forth by other readers. Whether it be the name of a person signing veries, the identification of an unknown station or a tip on when to hear a needed broadcaster, readers are unusually generous in coming to the aid of fellow listeners.

"The following are answers to questions asked by readers in the January RADEX," submits Jack Welsh, Kingston, Ill. "The station on 1150 kcys, heard by George Holland, Jr., is definitely XEL, announcing as 'Ek-



kis, ay, el-lay.' They are heard all night. The station heard on 670 after WMAQ signs off is XELO. (Since moved to XEPN's spot on 730—Ed.) The French-speaking station on 1210 kcys, heard by Capt. E. N. Massey, was also heard here at 6:15 a.m., EST. They announced as WCOU, Lewiston, Maine."

Others to identify the French-announcing station as WCOU are Warren R. Lades, Egypt, Pa., and Earl McDonald, Portland, Me. Mr. McDonald goes on to advise that WCOU broadcasts this French program every morning from 6 to 7 a.m., EST, and on Sundays from noon to 1 p.m., and adds that he wrote direct to Captain Massey with this information.

It is hardly necessary to note that the latter service is of particular value to the listener who made the original request for information. By the time a letter gets into this section and is answered by a reply to the section, considerable time has elapsed. If those able to answer a question would drop a penny postcard to the DXer desiring the information, the time would be cut in half. Of course, for the benefit of other readers who might desire the same answer to a question, it is always well to forward a duplicate of the answer to this section. Then everybody interested will have the data.

"Well, the buzzing noise has stopped a little now," proclaims Peter A. Clarius, 11 Marianne St., Port Richmond, Staten Island, N. Y., "and I was able to add the following stations to my log: WJE, WCOU, WKZO, KMBC, KITE, WRR, KLCN, WBAP, WHLS, WPIC, WDAN, KWOC, KFAM, KDNT, KPAB,

XEL and WJHL. This brings my BCB total up to 621, with 559 verified. Nothing heard of FQN on their recent NRC special. I received a very nice verification from WPAY in letter form, signed by Maurice L. Myers, chief technician, in which he stated that he was very much interested in DXers and DXing. I am using a 7-tube Lafayette and a 5-tube Sparton midget, with just a straight wire for the Sparton aerial and a 60-foot doublet for the Lafayette. Would be glad to correspond with all persons interested in DXing."

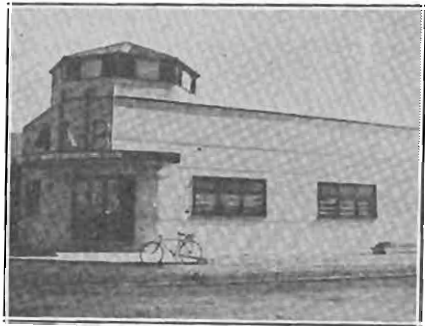

*Station 4SB, in Kingaroy, Queensland, Australia, a two kilowatt station working on 1060 kcs., which has been heard in the United States. Kingaroy is north of Brisbane, about 150 miles, in the center of the peanut, grazing and dairying Burnett District. (Courtesy of A. C. Tarr).*

"The broadcast band is plenty good these nights," affirms Stanley Troth, Phillips, Texas. "The 100-watters come rolling in like the big powerful stations. The stations in California seem to have longer operating hours than those elsewhere. The West Coast is a regular gold mine for the beginners who want to add to their BCB log. Some of my best catches

are CFCN, CJRC, CKLW, KIT, KGGC, KGLO, KLS, WBZ and WBZA. Several mornings in a row I heard a very weak signal on 870 kcys. It was a foreign station. They were playing stringed instruments and the singing sounded Oriental. I wonder if it could have been JOAK2 at Tokyo. They were on from 6 to 6:30 a.m., EST.

"Most Eastern stations come in well after 6 p.m.," asserts G. M. Kosolapoff, Dayton, Ohio, "especially the high power New York City stations. WFAA from Texas is a sure R9-plus bet, while the 50-KW Californians come in almost as well. In general, if the old weather map does not show bad spots, I usually have a very good evening."

#### Counting Stations

Periodically, various questions about DXing come up for discussion around the RADEX Round Table. Occasionally, readers will submit formulas for obtaining confirmations, theories on how special programs should be arranged, abstracts on how to eliminate all-nighters, local noise, sunspots or statics, recipes for hearing stations buried below a barrage of interference, and so on down the line.

It's been some time since we've had any opinions on what stations to verify and how to count them, but, just to make up for lost time, here are four contributions.

"Under the system I use," preambles T. R. Grosvenor, Wichita, Kans., "it would be quite impossible to build up an impressive log. For instance, I do not make an attempt to verify stations in my own state. Also, I never verify regional stations if I am able to tune in any of their regular

broadcasts. I never verify powerful stations anywhere unless I cannot hear them on their regular schedules or unless I hear them testing and they ask for reports. For that reason, the only big veries I have are from WRVA, KSL, WBOQ, WBT, WSE and WSM."

"My log now stands at 735 stations," declares Kenneth R. Leu, Rockford, Ill., "every one of which is on the air at the present time. As there seem to be no set rules for DXing, I have my own set: 1) I never log a station until the call letters have actually been heard, so that eliminates the unreliable, hit-or-miss process of identifying by the process of eliminating; 2) A change in the frequency or power of a station makes no change whatsoever in my log. (The wisdom of this rule is based on the following illustration—if a friend of mine moved to a different part of town, or put on 50 pounds additional weight, he would still be my same old friend, and by no stretch of the imagination could I call him a new friend.); and 3) I drop all stations from my log as soon as they are deleted or otherwise go off the air, unless the shut-down is only temporary. I have no interest in stations which are inactive or defunct. If I included in my log all of the stations that I have heard since 1923, my list would be near the 2000 mark, including short waves."

The entire situation is pretty well summed up, if not cleared up, by Larry Lundberg, Minneapolis, Minn., who writes:

"There never was and there never will be any one system that will be fa-

avorable to all DXers. In a recent meeting of the Minnesota DXers, this question was brought up, and not a single DXer agreed with the others on a method of counting his veries.

"Some listeners count a station two or three times, if they are verified on as many different frequencies. Personally, I count a station only once, no matter on how many frequencies I may verify it. Of course this brings up the old argument that a station may be heard well on one frequency and then may not be heard at all on a different channel.

"I count a station over again if it changes call letters, although I know that some listeners disagree with me. Also, if a station changes its location, I call it another station—and yet there are DXers who will not count such a move unless it is to another state. And these same DXers will count a station a second time if it moves to another city in the same state and changes its call at the same time.

"There are many different methods of counting veries, and each one has his or her own system. After all, each individual likes to run his hobby to his own particular tastes. I believe each listener should count his veries the way he wishes, for he is the one who must get the enjoyment out of his hobby."

"So far my old Harrisburg log with the Philco 9 1B has only gone up to 175 stations, of which not more than 40 odd are from the FCC tests," writes Henry J. Leinbach, Jr., Nanticoke, Pa. "Here in the new location, I came across this one: when a fellow uses a different receiver, must he start up a new log? I decided

that I didn't have time to do that, so I would just augment the Stewart-Warner log with entries from the RCA-Victor log, making notes to indicate when the latter receiver got the station. Ideally, I figured a whole new log should be started."

So far, without half trying, we've managed to uncover a lot of angles on what to do after a station has been heard (as if there isn't enough to worry about in the mere struggle to hear the station). There is one fellow pays no attention to a certain group of stations. One listener doesn't count changes in call or location, while another DXer does and yet another insists that they occur at the same time. And so on into the night.

It is almost a foregone conclusion that Count De Veries is going to jump overboard with the whole problem one of these issues, so DXers with axes to grind might get into the battle royal by sending in their opinions.

#### Reports and Resumés

"I have been DXing for a couple of years," admits Olin McDivitt, Eldred, Pa., "and have found it a very interesting hobby. At present my log stands at 636 stations heard and includes stations in Canada, Cuba, Mexico, Puerto Rico, Guatamala, Costa Rica, Argentina, Brazil, France and the Bahamas. Some of my better catches include Paris PTT, ZNS, CIRM, WILL, TIPG, WGAN, XET, WHEB, KFPY, XEW, PRG2, LR1, XERB, CHSJ, TGW, WPRP and WHBF. Last night, both CHNC and CKPR were heard on their new frequencies of 610 and 580 kcys respectively. A few nights ago, the little 250-watt WHBL at Sheboygan, Wis.,

came in and drowned out everything else on the same frequency, including WFBC and the Brooklyn stations. My receiver is a 1936 11-tube RCA communications model. I use two aerials, both 50 feet in length. One runs East-West, and the other is in the form of a triangle, which proves very good for both short and medium wave work."

"Latest veries to be received here are KYSM, KHUB, WHMA, WKST, CJLS, KUTA, TGW, WPG, WAPO and KGKY," gloats Jim Walker, Romney, W. Va. "The latest catches include XEM, the new Mex on 1390; XEBZ; CX18, heard December 28th on 890, covering KFPY; HJ1ABN, Barranquilla, Col., heard January 1st on 1190; and YV1RA, covering KFAC from 5:30 to 5:50 a.m., EST, on December 31st. Total heard to date is 853, but as I didn't start to verify right away, I'll have to log some of them a second time. Know anything about XEBZ? Two reports to them have been returned marked 'No such station' and 'Not claimed.'

"Here are a few sign-on times for you: WCHS and WMMN on at 5:30 a.m., EST; WKAQ on at 6; CJLS on at 6 for a few minutes and then off until 9; and CHSJ on at 6:30. XEBS has been signing off lately right on the dot at 1:08 a.m., EST, while XEO goes off at 3. XEAI seems to be on most all night.

"On some of my delinquent veries, I tried addressing my reports to the 'Chief Engineer of Radio Station —' and that has brought the veries back in a hurry. They seem to appreciate the reports, too."

"I am a regular RADEX reader and enjoy it very much," compliments Al-

bert Waterfield, Toronto, Ont. "Although I am a student and thus have to limit my DX activities, I have built up a log of 287 stations in two and a half years. This isn't so bad, considering that I have never DXed after 2 a.m. Up to Christmas, I was using a 10-year-old 7-tube DeForest Crosley, but my brother and I got a 1939 8-tube Rogers for Christmas. I am using a Philco vertical antenna with fine results. I have been confining my listening to the broadcast band, but I may try the short waves now that I have an all wave receiver."

"I have been DXing about one year now," supplies Robert Trubee, Brentwood, N. Y., "and my log stands at 340 stations heard on the broadcast band. I have yet to hear any trans-oceanic stations. Some of my better catches are LR5, TGW, TGI, TIPG, ZNS, XET, KOB, WKAQ, CFRN, CFQC and CMJE. I hope to increase my log considerably when I get around to listening to the FCC frequency checks. My receiver is a 1937 9-tube Silvertone."

#### More Daytime DX

There seems to be little doubt but what many listeners are becoming intrigued by daytime dialing. Strictly speaking, we suppose, it can hardly be called DX, since reception is necessarily limited to local and semi-distant stations. However, there is an odd fascination in seeing how many stations can be heard at mid-day and how far it is possible to hear. There seems to be as much satisfaction in hearing a 50-kilowatt a thousand miles away at high noon, as there is in tuning a 100-watt across the continent in the early morning.

"Starting at 10:30 a.m. this morning, January 1st," relates E. C. Stewart, Washington, D. C., "I started out to see how many stations I could hear in the daytime. Using an old 8-tube Westinghouse, I naturally heard the locals WMAL, WRC, WOL and WJSV. Within a 50-mile radius, I could hear WFMD, WCAO, WBAL, WCBM and WFBR. Was also able to hear WTBO, WSAL and WJEJ, each of which came in with fair volume. Then I was able to hear WJZ, WOR, WLW, WFIL, WRVA and WABC. Other stations were coming in, but due to church services I was unable to get the call letters."

"Tried my luck with daytime DXing on January 11th," reports Glenn L. Thompson, Chicago, "and, exclusive of locals, was able to hear KSD, WILL, WKZO, WMT, WOW, WDAF, WTMJ, WGBF, WOI, WSM, WLW, WJR, WEW, WGY, WFAA, WCCO, WHAS, KOA, CBL, WKAR, WBAA, WTAD, WHA, KMBC, WHO, WDW, CKLW, WIBC, WTAM, KMOX, WISN, WOWO, WWAE, WMRO, WIBA, WHBL, WCLS, WSAI, WRJN, WIRE, WROK, WMBD, WKBZ and WOOD. These were heard between 11 a.m. and noon. The day was cloudy and the temperature about 34°."

#### Having Fine Season

"I have been having a very fine year so far with my DXing on the broadcast band," states Gerald Harris, Kansas City, Mo. "Some of my best catches are KEX, CBL, CKY, WBEN, WABC, WEAJ, CJRM, CMCD, CMCY, WNAX, KMA, KFNF, WOR, KGO, KPO, WGY, WBZ and several others."

"I have been DXing since 1923," briefs Don Sollenberger, Inglewood, Calif., "when I started with the usual crystal set and a dinky aerial. Today, however, I am using a Miller 5-tube all-wave super and a 114-foot flat-top aerial, with a 60-foot lead-in. I have received and verified 19 countries on five of the six continents."

"Since my last report, I have heard CMOK, CMK, WLLH, KVGB, KOIN, WCAX, WMFF, WCAD, WLNH, WIL, WGRC, WHA and WIBU," reports Leon Grossman, Rochester, N. Y. "I've been DXing since April, 1937, logging 316 stations on the BCB and verifying 78 out of 89 reports. Several other DXers and I have formed the 'World DX Club' and are anxious to add new members. Our dues are \$1.50 for the first two years, and \$1.25 a year thereafter. Bulletins will be published weekly. I will be glad to supply details to anyone who writes to me."

"Well, another year of DXing is past," writes Richard Wright, 5762 Harper Ave., Chicago, "and the BCB log now stands at 632 stations heard, with verifications from 229 U. S. stations and 61 foreigners. All Canadian provinces are verified, except Nova Scotia and Prince Edward Island, while in the United States I am shy only Nevada. In all, I have heard 32 stations in Canada, 25 in Cuba, 21 in Mexico, two in Hawaii, four in Puerto Rico, and one each in the Bahamas, Costa Rica and Guatamala. Several friends and I are compiling a list of transmitter locations, where it is different from the the studio location, so I'd appreciate any stray tips your readers would care to send in."

Joseph T. Lippincott, East Vassalboro, Me., submits a detailed report of his DXing during the second week in January. On January 10th, he heard Rennes, Poste Parisien, Radio Normandie, KRLD, WAIR and KFAM; January 11th—Rennes, Paris, Radio Normandie, XEFE and KWEW; January 12th—Rennes, Poste Parisien, Radio Normandie, Bordeaux, XEAC, KJR, CFAC, XELO and HJ1ABN; January 13th—Lille, Sarragossa, Toulouse, Poste Parisien, Rennes, Bordeaux, Radio Normandie, Nice and Lille, as well as doubtful signals from Sofia, Tunis, Milan, Horby, L'île de France and Radio Cité; January 14th—Radio Normandie, Rennes, Poste Parisien, Lyon, and Lille; January 16th—Rennes, Radio Normandie, Poste Parisien, Lyon, Lille, Radio Paris (182 kcys), Deutchlandsender (191 kcys), Milan, Tunis, Bordeaux, Radio Cité, Strasbourg, WCOV and KTSW. The receiver was a 1938 11-tube General Electric, with two 200-foot aerials, one directed Northeast and the other towards South America.

#### DX on Long Waves

It will be noted that two of Mr. Lippincott's European catches were heard on long waves—Radio Paris on 182 kcys and Deutchlandsender on 191 kcys. For some time it has been apparent that American DXers have been neglecting long waves as a medium for trans-Atlantic reception. In the past, this has been undoubtedly due to the fact that few American-built receivers would cover this wave band. Also, there has been little publicity for this type of reception, with the result that many listeners were unaware of its possibilities. However,

many present-day models have been designed to tune up to 2000 meters, so there is no reason why DXers in this country should not avail themselves of an opportunity to add to their log of TA's.

"Long wave reception has been very good here," reports L. R. Greenman, Conneaut, Ohio. "Moscow on 172 kcys and Berlin on 191 kcys have been heard regularly. Droitwich on 200 kcys came in last evening almost like a local until it signed off at 7 p.m. Paris on 182 kcys also shows good strength, as does a station on 166 kcys which I believe is Lahti. All of these stations can be heard from midnight until 2:30 a.m."

Additional evidence of what can be heard on long waves comes from Evan B. Roberts, Danvers, Mass., whose report is covered in detail in Count De Veries' article elsewhere in this issue. However, it is interesting to note the long wave stations which he has been hearing: Kansas on 153 kcys, Hilversum on 160, Radio Romania on 160, Lahti on 166, Moscow I on 172, Radio Paris on 182, Ankara on 183, Deutchlandsender on 191, Droitwich on 200, Reykjavik on 208, Motala on 216, Warsaw I on 224, Luxembourg on 232, Moscow II on 232, Kalunborg on 240 and Kiev I on 248.

These catches would make impressive additions to any trans-Atlantic log, so a word to a wise DXer should be sufficient.

#### Notes on TP's

"The articles on foreign reception interested me," greets Albert J. Bartholomew, Bradford, N. Y., "and I am sure they proved of value to beginners as well as to old timers. I have had quite a little success with foreign

reception, particularly with the TP's, and I would like to give my theory. I have heard and verified more than 25 stations Down Under, and although I don't pretend to be an authority, I do believe that my record has been above the average here in the East.

"My study of the peculiarities of trans-Pacific reception has taken place over a period of six years. I have found that, almost without fail, reception from Australia and New Zealand has been best when the moon is past full and is on the wane. During the new moon and until just beyond the full, reception has always been very poor, but during the wane signals reach a peak. As you state in your article, the signals are best in October, but I have also found that they sometimes continue good through November and into December. In fact, the best morning I ever struck for TP's was December 2, 1935, when more than 20 of them could be heard. I only had time to get verification data from four of them, but, had time permitted, it would have been a cinch to get 20 of them—and that would have included stations with as low as 500 watts power."

Several times in the past, listeners have advanced theories on the effect of the moon on DX reception. It would be interesting to check Mr. Bartholomew's theory about TP's being best during the wane of the moon—and observations might be extended to cover the TP's and SA's, too.

### "Verie Signers"

From Orestes Zoniades, Newark, N. J., comes a worthwhile suggestion to aid DXers who have trouble in obtaining verifications from certain stations. "Might I suggest," he writes, "that in each issue of RADEX you print a list of the persons who sign the veries from the different stations?"

To start the ball rolling, he submits the following list of officials who have signed recent letters of verification for him:

WCOC—John B. Rogers, Chief Engineer.

WSLI—G. G. Benson, Chief Engineer.

WGRM—C. A. Perkins, Chief Engineer.

KGFI—Fred Hammond, Engineer.

WLVA—J. T. Orch, Engineer.

WGIL—Paul Kalbfleisch, Assistant Engineer.

KHBG—A. F. Schultz, Chief Engineer.

If other Radexers will check over their recent veries and forward the names of the signers, in no time at all we will have a long list for the reference of DXers throughout the country.

---

### THE IMPROVED RADEX

**WILL HELP YOUR FRIENDS TOO!**

WILL YOU PLEASE HELP BY  
TELLING THEM ABOUT IT?—*The Editor*

## STATICLESS RADIO

● When the ultra-high frequency bands were first opened up for experimental broadcasting, the Federal Communications Commission assigned licenses in the hope that this type of broadcasting would provide strictly local coverage, permitting a large number of stations, not widely separated geographically, to broadcast simultaneously on the same frequency without interference. Theoretically, broadcasting on duplicated channels should be possible on the u.h.f., since the coverage of these stations is claimed to be only from 50 to 75 miles at the most.

As soon as tests started, however, such stations as W8XAI, W6XKG, W8XWJ, and more recently, W9XA, demonstrated that interference is possible from stations on the same frequency, with even the entire continent separating them. It is true that in general practice, the "line of sight" idea holds good (that is, the ultra-high frequencies can be broadcast only as far as one can see), but DXers know that frequently it is possible to enjoy reception from radio stations regardless of frequency or distance.

While the FCC has recently expressed pleasure at the progress made so far on the u.h.f. bands, it is enlightening to learn that they are also interested in studying another type of transmission. If the new system proves to be more desirable than the present "apex" broadcasting, we shall see big changes, no doubt, in the entire apex broadcasting scene.

As a solution to the problem of local coverage, Major Armstrong, of superheterodyne fame, offers a new system of broadcasting. His forty kilowatt W2XMN, high on the Palis-

ades, overlooking New York City, promises a static and interference-free primary area, and practically no secondary service area. His special single-masted aerial, 400 feet high, with three 150 foot crossarms, is designed to eliminate the sky wave, which is responsible for the transmission of shortwaves over great distances. With the sky wave suppressed, and the ground wave held close to the ground, the signals can be heard up to about 100 miles away. Beyond this point, however, they cannot be heard, and it would be possible for another station to share the same frequency, without interference, if the stations were separated by only about 100 miles, as New York and Philadelphia.

W2XMN is a frequency modulated station. Other radio stations employ amplitude modulation. In amplitude modulation, the carrier wave remains constant, and the voice currents carried on it vary. In frequency modulation, the power remains constant, and the carrier itself fluctuates. Frequency modulation, therefore requires a very wide band in which to work. In fact, the band required is so wide that only five of these stations could be accommodated in the standard broadcast band.

W2XMN, and two or three other stations which have been licensed to use this modulation system, work on the ultra highs, just above the regular apex broadcasting channels. At present, the frequency is 42800 kilocycles.

It is difficult to explain why this station is staticless. It has been pointed out, though, that the very high frequencies are normally free of static, both man-made and natural. And of



course the very wide transmission band helps a lot. A writer in the *New York Times* described it quite aptly, saying that the carrier wave, constantly varying, is never still long enough for static or other noises to mix with it. In order to be reproduced, the static would have to change in intensity and tone exactly as the program does, in order to be tuned in.

When regular broadcasts start, W2XMN will relay the programs of WQXR. Ordinary radio sets will not receive these broadcasts, but receivers are being built by two companies, to be placed on the market soon. The new receivers will be designed to receive broadcasts of both the frequency and amplitude modulated stations.

If Major Armstrong is right, and he has been right a great many times, his new system will be in general use within five years.



- The International DXers Alliance, with headquarters in Bloomington, Ill., has seven local chapters situated in different parts of the country. The local chapters afford an excellent opportunity for DXers to meet in person and discuss their DX reception and problems.

The Auto City Chapter meets on the third Tuesday of every month, at the Detroit News Building, in Detroit. Meetings start at 8 p.m.

The Beta Chapter, gathers at the home

of Edward Goss, 812 Prospect Place, Brooklyn, N. Y., on alternate Saturday nights.

The Golden Gate Chapter has recently been reorganized. Anyone living in the vicinity of San Francisco can obtain information about meetings by calling VALEncia 0612, or writing to G. Sholin, 55 Lapidge St., San Francisco, Calif.

DXers living near Regina, Sask., can obtain information about the Regina Jubilee Chapter by writing J. C. Hodges, 1551 Elphinstone St., Regina.

The Secretary of the Southern California Chapter, Harold B. Clein, will be glad to give information to anyone inquiring about meetings. His address is 1821 Santa Ynez St., Los Angeles, Calif.

Listeners in the southern part of New Jersey are invited to attend the meetings of the South Jersey Chapter, held every Saturday night at the home of L. Cavileer, 1223 Keswick Ave., Haddon Heights, N. J.

- The International Listeners Association of Dryden, Washington, and the World Wide Hobby Club of Dayton, Ohio and Minneapolis, Minnesota, have combined their membership. The first bulletin issued by the enlarged organization was the February, 1939 issue; it's new name is "QSA5, the Hobby Fans' Bulletin." QSA5 will continue to present radio information, as in the past, and a new department, to be headed by Larry Lundberg, formerly of *Hobbymag*, will cover the hobbies of stamp collecting, coins, postal card exchange, and others. Headquarters of the International Listeners Association are at Dryden, Washington, and the president is Floyd Slosson.

- The secretary of the Universal All-Wave League, Elmer Neuman, announces that the organization is making a drive for members, and that all inquiries addressed to him will be answered promptly. The League publishes a bulletin which contains a long list of members who exchange SWL cards. Their address is Box 8363, Pittsburgh (18), Pa.

- An eastern get-together of the members of the NRC will be held in Philadelphia in June, at the home of George Brode. Members will be advised later of the exact date. The National Radio Club will also have a convention in Erie on Sept. 2 and 3.

## HAM HOUNDING . . .

●●● By HUGH HUNTEM

● Well, well, here we are, back again, after a month's vacation, and we certainly hope that, in the meantime, all of you "dial bruisers" have continued to meet with success in hounding the hams. We've found conditions to be excellent, at times, and, as a result, several new countries have been added.

March, in our opinion, is the best month of the year for 20 meter reception. Europeans and North Africans are often heard from early in the afternoon until, as late as, 4:30 am; South Africans will frequently be heard, especially around midnight, during the early part of the month; Asians will continue to come in during the morning hours; VK's and other South Pacific signals will occasionally be heard at 4:00 pm, and frequently at 1:00 am and 7:00 am; and our hemisphere will be received at almost any hour of the day.

### DX Contest

As all of you amateur enthusiasts know, the American Radio Relay League's eleventh annual international DX phone contest will occur this month. The starter's gun will be fired at 7:01 pm (EST) on March 18, and the boy's will be calling CQ DX contest from this point until 6:59 pm, March 26. This contest certainly provides the listener with an opportunity to log virtually every recognized country in the world, and those of you who have the necessary persistence and patience, requisite to a successful DX fan, will add numerous countries to your log of nations heard.

It will be noticed that, during the contest, the VE and W stations will be in one group and the balance of the world will be in the other. Scores will be tabulated in the following manner; for example. If a W amateur contacts 100 stations in 40 countries, the 100 will be multiplied by 40, making a score of 4000. In other words, it is not only to the operators advantage to work as many foreign stations as possible, but also to land the greatest number of countries possible, as each additional country worked furnishes the amateur



*CN8MU, Meknes, Morocco, one of the most popular trans-Atlantic stations on the air, sends this card.*

with an additional multiplier.

Listeners will also notice that stations will exchange a string of numbers when making contact. Here's the dope on this situation. Station IOU is in the contest; he has adopted 246 as his identifying number; he then contacts ILY and receives him QSA 5, R7. IOU will pass the following numbers to ILY-57246. In other words, ILY will receive his signal report plus IOU's identifying number. This group of five figures serves to establish confirmation of the QSO when the scores of the contestants are tabulated at ARRL Headquarters.

### Cairo Speaks

When the International Telecommunications Conference parlied at Cairo, they had to change something to make it appear as though their time was not

entirely wasted, so they changed the old and faithful Q code into what is now known as the R S code. This new code was supposed to have gone into effect at the first of the year, but a few moments of listening on 20 meters will establish the fact that the amateurs are not observing this change. We wonder whether or not the aforementioned exchange of numbers will be affected during the DX contest?

Here's the new R S code (courtesy of Bob Blanchard, Flatbush, N. Y.)

#### Strength

QSA1—Barely perceptible.

QSA2—Weak.

QSA3—Fairly good.

QSA4—Good.

QSA5—Very good.

#### Readability

QRK1—Unreadable.

QRK2—Readable occasionally.

QRK3—Readable with difficulty.

QRK4—Readable.

QRK5—Perfectly readable.

#### Western Hemisphere

Many of our readers have requested information concerning rarely heard countries in North and South America. We'll admit that there are numerous countries where there may be but one or two 'phones and it is a matter of being at your receiver at the proper time. We'll list a few of the countries in which there are no broadcast stations and also countries whose stations are rarely heard or difficult to verify.

**ALASKA**—K7's are rarely heard in the Eastern portion of the country. We suggest trying for K7AOC on 14.155 megs. and K7FST on 14.23 megs. Both of these stations are receptive to DX reports and both QSL. K7FBE in Unalaska, Aleutian Is. is another. His frequency is approximately 14.24 megs. Many listeners consider the Aleutian Islands a country, for DX purposes, because of their great distance from the mainland of Alaska.

**ANTIGUA**—A tough country to hear and even tougher to verify. The two best stations, VP2AE (ex VP2DA) and VP2AT, refuse to confirm reports of reception. We have heard, however, that VP2AD, who operates on the low fre-

## RADIO AMATEUR CALL BOOK

### LATEST EDITION

Lists over 40,000 amateurs in every country in the world, and complete lists of all the high frequency commercial stations. Every listener interested in amateur stations should have one. 292 pages.

We pay the postage.

**RADEX**  
362 Cedar Lane,  
TEANECK, N. J.



**\$1.25**

quency side of the band will QSL, so be on the lookout for him.

**BAHAMAS**—There's plenty of 'phones in Nassau but don't pick on VP7NC, because he doesn't QSL. We are quite certain that any of the other stations will QSL for an accurate report, such as VP7NA, VP7NS and VP7NU.

**BARBADOS**—This island also boasts of numerous stations who get out quite well. We have QSL's from VP6FO, VP6LN, VP6TR and VP6YB. All four of these are heard on the low end of the band with VP6FO being the most consistently received.

**BOLIVIA**—CP1AA and CP1BA are the only CP stations we have heard. The former requests a self-addressed envelope, a home-made card for him to sign plus the conventional IRC; while the latter occasionally QSL's for an IRC, only. Both have been heard on the low end of the band.

**BRITISH HONDURAS**—Another hard country to verify. ZIK2, the broadcast station rarely verifies and according to Art Hankins of Latrobe, Penna., VP1BA refuses to confirm his 'phone. We suggest that you look for VP1DM, who operates on both ends of the band. He is always pleased to receive reports and his QTH is Duncan H. B. Macmillan, Box 199, Belize.

**CANAL ZONE**—To the best of our knowledge, every station in the Canal Zone verifies; in fact K5AH, K5AF and NY2AE, apparently, QSL'd by return mail. If you are ever in doubt about a

K5's QTH, merely address your report to the Canal Zone and it will reach the station OK.

**DOMINICAN REPUBLIC**—Getting the broadcasters in this country to verify is like pulling teeth. We suggest that if you want to save money, to be on the lookout for one of the following four stations as they QSL in good time. HI1C, HI3N, HI5X and HI7C.

**FALKLAND ISLANDS**—Only one station has ever been reported, VP8OA, who is supposed to operate around 14.05 megs. We'd sure like to have this one!

**JAMAICA**—Several VP5 'phones are heard quite well but many of them refuse to verify reception reports, such as VP5AF and VP5SI. On the other hand, VP5BR, VP5GM and VP5PZ do QSL, according to reports.

**LABRADOR**—VO6J at Sandgirt Lake is again on the air but with a different operator. For confirmation, send your reports to 5694 Waverly Street, Montreal, P.Q., Canada.

**NEWFOUNDLAND**—Several stations with good signals are on this island. Some are VO1D, VO1T, VO2N and VO4A, who do QSL; and VO1I and VO2Z, who do not QSL.

**NICARAGUA**—The 'broadcasters in this country are about as poor as those in the Dominican Republic when it comes to verifying. If you desire a YN card, look for YN3DG who occasionally operates on the high end of the band. Send your reports to Dennis Gallo in the city of Leon.

**PARAGUAY**—If Radio Cultura doesn't answer your reports, try ZP2AC, 14.1 megs. with a return card. He is occasionally heard during the evenings with a fair signal.

**PUERTO RICO**—The K4's are plentiful and easy to hear, despite their having to operate in the American phone band. As they are so numerous, we list only those who are reluctant to QSL'ing; K4DDH, K4ENT and K4UG.

**ST. LUCIA**—As stated in the January RADEX, look for VP2LB and VP2LC on the low end of the band. Both have verified for many listeners.

**ST. VINCENTS**—A VP2SA has been reported by several listeners as operating

THE BOWDOIN KENT'S ISLAND EXPEDITION  
BAY OF FUNDY

**VE1IN**

Headquarters Address:  
Thomas Gross - W1JZM  
Brunswick, Maine, U.S.A.

TRANSMITTERS:- 1000 watt phone on 14,885, 4797.5, and 3885 Kc. - Harvey UHX-10 on 3.5 and 28 mc. aboard "Scientist", POWER SUPPLY: 2 gasolene driven plants with 5 kw output, RECEIVERS: RME-59 with DB-20 pre-selector, Masterpiece V, and SW-3. VE1IN has a special frequency assignment, 4.8 mc., for bird song recording and rebroadcasting purposes. A 4000 foot terminated rhombic antenna is used on this frequency.

To Radio SWLs: We are pleased to verify your reception of our station on 3885 Kc. Remarks  
Your signals RST \_\_\_\_\_ Your report was interesting but  
Cw, WJZM "Tom" have no SWL only YN's who  
WJKE "Fred" would long for an XYL?  
WJKU "Murray"

*This interesting veri from Canada's  
Bay of Fundy was submitted by Robert  
Blanchard.*

on a frequency of 14.2 megs., but with a none too strong signal.

**SURINAM**—This one is, perhaps, better known to most of you as Dutch Guiana. The only 'phone we have heard reported is PZ1AA which operates on 14.27 megs. This station takes a couple of years to verify, so we have been told.

**TRINIDAD**—20 meter 'phones are rarely heard from this country. VP4TH is rarely on the air and VP4GA has returned to the States. The best bet is VP4TK who operates on the low frequency side of the band. His QTH is Paul C. Alonzo, No. 74 Duke St., Port of Spain.

**VIRGIN IS.**—The one and only is K4ENY who operates on the high end of the American phone band. The operator, Lieut. Wm. Smith, who is located at the Fleet Marine Base in Charlotte Amalie has a tough time in keeping up with his QSL'ing and requests that listeners send a reply card that he need merely sign and drop in the mail.

**Hawaii Calls**

One of our most active reporters is C. J. Fern, Jr. of Lihue, Kauai, Hawaii who writes that K6OXT, K6FKN and K6PLZ all QSL for return postage, but that K6NTV does not. He also informs us that less than four per cent of the SWL's in the States send return postage when writing K6 stations.

Mr. Fern has had exceptional success in logging Asia, Oceania and Africa, but, to date, has heard but one European, G3DO. Some of his better catches are

VK9XX, VQ2HC, ZE1JX, XZ2DY and VQ4KTB.

While on the subject of Hawaii, we believe it advisable to inform you that K6BAZ, K6JLV and K6KMB, also will not confirm reception reports. K6BNR, K6CMC and K6NZQ, however, will QSL.

### Canton Island

A brand new country to log is Canton Island in the South Pacific. KF6DHW is the station in mind and he has a very good signal. Look for this station on the high frequency side of the band.

Another newcomer to 20 meters is VPD2 in the Fiji Islands. VPD2 was heard on an announced frequency of 14.248 megs. and was attempting to contact VR6AY. It is believed that these two Oceanic stations keep a daily schedule.

Jack Wells of Phenix, Alabama reports some good catches which include J7CR, 14.29; ZS3F, 14.07; ZS5CL, 14.13; CN8BA, 14.07; SU1MW, 14.11; ZL2BE, 14.21. Jack considers J7CR his best catch and is so fortunate as to have him verified.

### Venezuela Reports

Walter Kammann informs us that DX is quite good in Venezuela and encloses a list of QSL's to prove his statement.



*The Association of Amateur Transmitters of Morocco is a large and influential union which includes all the well-known CN8 amateurs in its membership.*

Here are a few that we wouldn't mind having verified. ZK2AA in Nieu, FXD in the Republic of Lebanon, CT2BO in the Azores, and VK4HN in Papua. Other fine QSL's include VK6LJ, OX2QY, Radio Malaga, CN1AF, VU2CQ, PK2DF and HB9AY.

Walter also informs us that many Radexers have written him but he has a difficult time in keeping up with his correspondence; however, he always manages to answer the YL's by return mail, so here's your chance, ladies—the QTH is P.O. Box 1891, Caracas. Hi Walter!

### Skiffs

Many listeners report reception of various ships on 20 meters. One which has been heard quite widely is LA4U, 14.07 megs. The operator stated that the ship was bound for Europe and that his station had an input power of 11 watts. The most often reported is the S.S. California which is bound for the Antarctic. W9AM is the operator of the ship's transmitter and has been heard on about 14.14 megs. using various calls, such as ZX4M and ZX9AM. The rig has a power of 15 watts. Irregular skeds are kept with W9EYW at around 5:00 pm EST.

### Farewell

Well, this is just about all the space that we are able to utilize so we'll have to sign-off for another month. However, as a bit of parting advice, we suggest that during the DX contest, tune whenever possible, for if conditions for this contest are anything like those of last year, rarely heard DX stations will put in their appearances at very unusual hours. Best of luck to all of you and don't lose too much sleep!

**THE IMPROVED RADEX  
WILL HELP YOUR FRIENDS TOO!  
WILL YOU PLEASE HELP BY  
TELLING THEM ABOUT IT?—The Editor**

## Amateur Calls Heard

The names and addresses of persons reporting stations shown in this list are indicated by small letters following the call signs. Key to the small letters is given at the end of the column.

### Ten Meters

CE1AO (*i*); CN8BA (*i*); CO2JJ (*i*); CO2RG (*i*); CO2WWM (*p*); CO7AB (*ip*); CO7CX (*p*); CO7VP (*p*); CT1KH (*i*); CT1ZZ (*i*); CX1FB (*i*); EI2I (*b*); EI2IJ (*i*); EI2L (*p*); EI9G (*i*); F3HL (*i*); F3KN (*in*); F8AB (*i*); F8MX (*i*); F8QD (*i*); F8UE (*i*); G1TK (*n*); GM6RG (*bnp*); G2IS (*n*); G2PU (*in*); G2VG (*p*); G3BO (*i*); G3FA (*n*); G5BC (*np*); G5BY (*i*); G5FH (*i*); G5FI (*p*); G5GS (*n*); G5KH (*i*); G5LU (*i*); G5SA (*ip*); G5TP (*i*); G5TV (*i*); G5WP (*n*); G6BW (*in*); G6DH (*n*); G6DL (*n*); G6GS (*p*); G6IA (*n*); G6LK (*n*); G6LL (*i*); G6UX (*n*); G6WT (*np*); G8CV (*i*); G8DM (*i*); G8GX (*n*); G8IX (*n*); G8IX (*n*); G8MA (*n*); G8MX (*i*); G8OO (*in*); G8QK (*n*); G8SA (*imp*); G8TW (*n*); HI7G (*in*); IIGW (*i*); I1KN (*i*); KA1ME (*i*); K4DDH (*n*); K4EIL (*i*); K4EZR (*bn*); K4FAB (*n*); K4FAY (*in*); K6MUL (*f*); K6MVV (*k*); K6OQE (*i*); K7GSC (*i*); K7GTP (*i*); LA3B (*i*); LU1DJ (*i*); LU4BH (*i*); LU7AG (*i*); LU9BV (*i*); ON4DM (*i*); ON4PA (*in*); ON4VA (*i*); ON4VK (*p*); ON4ZA (*i*); PAOEO (*n*); PAOFB (*i*); PAOWT (*i*); SM5SI (*n*); SM5WJ (*i*); SM6RF (*i*); SU1MW (*n*); TF3C (*i*); TG9AA (*ip*); TG9BA (*i*); TL2RC (*i*); VK2AFQ (*i*); VK2GU (*i*); VK4IP (*i*); VK6MW (*i*); VO2N (*i*); VP3AA (*p*); VP9L (*p*); VE1GE (*i*); XE2F (*i*); XE2LC (*p*); XE2SE (*i*); XE3X (*i*); YN3DG (*i*); YR5KJ (*i*); YS2LR (*i*); YV1AQ (*ip*); YV5AA (*i*).

### Twenty Meters

CE1AO (*i*); CE3AT (*c*); CE3BK (*cj*); CE3CG (*cj*); CE2CI (*f*); CE3DW (*cj*); CE4AC (*c*); CE4AI (*cj*); CN1AF (*dhlo*); CN8AB (*d*); CN8AF (*j*); CN8AJ (*d*); CN8AL (*d*); CN8AM (*l*); CN8AV (*l*); CN8AY (*d*); CN8BA (*o*); CN8MA (*d*); CN8MU (*j*); CO2AM (*g*); CO2BY (*p*); CO2HY (*p*); CO2LY (*i*); CO2RR (*ag*); CO2WL (*ep*); CO2WM (*g*); CO2WW (*ip*); CO2WWM (*p*); CO6OM (*ai*);

CO7AB (*ip*); CO7CX (*a*); CO7VP\* (*g*); CO8BC (*i*); CO8YB (*f*); CT1AY (*bdl*); CT1AZ (*a*); CT1CV (*d*); CT1OX (*d*); CT1PL (*d*); CT1PM (*n*); CT1PR (*d*); CT1QG (*dn*); CT1QH (*d*); CT1ZA (*a*); CX1AX (*j*); CX1VD (*o*); CX2AK (*j*).

EA8AE (*d*); EA8TD (*a*); EA9AH (*p*); E12EV (*c*); E12G (*f*); E12L (*f*); E16G (*fl*); E18J (*b*); F3NM (*p*); F3NT (*p*); F3OO (*n*); F8BX (*b*); F8DC (*b*); F8NT (*n*); F8UE (*bn*); F8VP (*j*).

GI5QX (*f*); GM5NW (*b*); GM6RC (*i*); GM8MN (*bfln*); GW3JI (*n*); GW5PH (*in*); G2AK (*n*); G2AV (*bn*); G2DV (*b*); G2UT (*p*); G2VG (*bn*); G2XN (*bn*); G3BM (*bn*); G3DH (*b*); G3DL (*b*); G3DO (*bcn*); G3QK (*b*); G3TO (*b*); G5BJ (*b*); G5BY (*b*); G5HK (*b*); G5II (*j*); G5JO (*a*); G5LJ (*j*); G5PW (*b*); G5ZG (*bc*); G6BC (*n*); G6DL (*n*); G6GA (*n*); G6IA (*n*); G6PC (*f*); G6TZ (*bn*); G6VX (*bc*); G6WC (*b*); G6WT (*n*); G6WX (*n*); G6XR (*b*); G8BU (*c*); G8MA (*b*); G8MX (*n*); G8ND (*n*); G8NY (*b*); G8SB (*b*); G8TD (*b*); G8UJ (*bf*); G8WS (*bn*); HC1JW (*f*); HC1PZ (*el*); HC2CC (*c*); HH2B (*acefin*); HH2PB (*bp*); HH4AS (*cefjn*); HH5PA (*acfhn*); HI3N (*aef*); HI5X (*aip*); HI7G (*cfjn*); HI7L (*n*); HJ3CBD (*c*); HK1AB (*p*); HK1AH (*p*); HK3BK (*i*); HK3CG (*n*); HK3CL (*a*); HK3CO (*b*); HK3JB (*f*); HK5EE (*ip*); HJ1A (*bp*); HR5C (*ei*).

KA1HS (*b*); KA1ME (*i*); K4EIL (*f*); K4ENT (*b*); K4EZR (*f*); K4FAB (*f*); K4FAY (*befbin*); K4FKC (*aen*); K4SA (*f*); K5AF (*abcefghino*); K5AH (*l*); K6BAZ (*i*); K6BNR (*eil*); K6EME (*i*); K6IOW (*i*); K6LEJ (*e*); K6MER (*f*); K6POZ (*i*); K7AOC (*i*).

LA1G (*bd*); LA4U (*p*); LU1DA (*cei*); LU2BG (*c*); LU2HF (*c*); LU3BAC (*ij*); LU3HA (*e*); LU4AB (*j*); LU4CZ (*c*); LU4DA (*e*); LU4PB (*j*); LU5CZ (*i*); LU7BK (*l*); LU8AB (*ci*); OA4AE (*i*); OA4AI (*j*); OA4AS (*i*); OH2OI (*b*); ON4BG (*p*); ON4DI (*bp*); ON4LW (*c*); ON4VK (*f*); ON4ZA (*bn*); PAOEO (*n*); PAOMZ (*bfj*); PY2AK (*cil*); PY2AT (*c*); PY2CK (*ce*); PY8AD (*l*); PY8AG (*p*); SM2UP (*b*); SU1CH (*d*); SU1MW (*o*); SU1RD (*av*); SU2TW (*f*); TG9BA (*bfin*); TI2AV (*f*).

**VQ2PL**Ex CR7AX, CR71A,  
and ZE1JD.Confirms the QSO with WBSWL at 427 GMT  
on Nov., 16 38 My kST 54 on ACR136 Rx.  
Transmitter 48 Watts on 14 Kcs.Railway Telegraphs, Many TNX QSO  
Rhodesia Railways, PSE QSL TKS  
Livingstone, 73  
N. Rhodesia. Peter L. Lowth.

*A card from one of the world's best  
known amateur operators, Peter Lowth  
of Livingstone, Northern Rhodesia.*

VE5AAD (i); VE5AEJ (i); VK2EH  
(b); VK2OG (b); VK3BZ (l); VK3KX  
(b); VK4KH (o); VO1B (be); VOII  
(p); VO1Y (ep); VO6J (m); VJ1BA  
(filn); VP1JP (i); VP1VA (i); VP2LC  
(b); VP3AA (bcfy); VP4BK (c); VP4TK  
(d); VP5PR (c); VP6FO (bc); VP6LN  
(in); VP6YB (f); VP7NA (f); VP7NC  
(c); VP7NS (cefp); VP7NW (c); VP9L  
(bc); VP9LY (f); VP9R (abil); VR6AY  
(el); VS7GJ (b); VU2CQ (o); VU2NU  
(e); VU2UC (o); W9AM (o); XE1BT  
(a); XE1CJ (o); XE1FY (e); XE1GE  
(f); XE1GF (g); XE1Q (ei); XE2AX  
(f); XE2IY (ce); XE3AO (j).  
YV1AA (c); YV1AG (b); YV1AP  
(i); YV2EC (f); YV4ABG (c); YV4AE  
(ceg); YV4AN (g); YV4AS (c);  
YV5ABF (c); YV5ABQ (cn); YV5ABY  
(inp); YV5ACA (c); YV5AE (i);  
YV5AK (l); YV5AN (c); YV5AP (f);  
YV5AQ (n); ZE1JR (i); ZE1JS (i);  
ZE1JY (i); ZL2BE (o); ZL2BI (d);  
ZL2UJ (i); ZL4BB (i); ZS1AX (eo);  
ZSIBL (o); ZS1CN (i); ZS2AF (di);  
ZS2AX (d); ZC2FY (i); ZS2K (d);  
ZS2N (dp); ZS2X (co); ZS2XE (d);  
ZS3F (o); ZS4H (diop); ZS5CA (e);  
ZS5CL (o); ZS5J (i); ZS5T (o); ZS6A  
(i); ZS4AJ (d); ZS6BR (d); ZS6DW  
(deio); ZS6DY (dp); ZS6EB (di);  
ZS6EF (d); ZS6J (o); ZS6S (b); ZS6SJ  
(d); ZS6W (i); ZU6P (d).

**The Reporters**

- (a) Robert Blanchard, Brooklyn, N. Y.  
(b) Philip L. Craig, Waterville, Maine.  
(c) Richard A. Craig, Waterville, Maine.

- (d) J. Ray Freeland, Fairmont, W. Va.  
(e) A. M. Hankins, Latrobe, Pa.  
(f) David Hill, Washington, D. C.  
(g) Lewis R. Hill, Maywood, Ill.  
(h) Carl Horton, Athol, Mass.  
(i) E. A. Knoff, Canton, Ohio.  
(j) Bertram Podall, Gilman, Vermont.  
(k) Wm. Scott, Johnson City, Tenn.  
(l) Vincent Stasen, Philadelphia, Pa.  
(m) Carl E. Sylvester, Columbiaville, Mich.  
(n) Walter Welch, Lynn, Mass.  
(o) Jack Well, Phenix City, Ala.  
(p) Cyrus Will, Kenilworth, Ill.

"When I think back to June, 1937," reminisces Elwin H. Covey, Napa, California, "I can certainly wonder at what strides DX has taken. I started then with a small three-tube Eilen regenerative kit. After nearly three months of ear-straining, I had built up a total of 46 BCB stations. Then a cousin re-built the set into a four-tube regenerative model with electrical bandspread, plug-in coils and earphones. I was lucky enough to be coming into the winter DX season when I got the new set, and in one week's time I boosted the total from 46 to 85. At the end of the winter season, I had something over 130 in my log. With the help of the FCC checks, my present total is 208 stations—which isn't so bad for a four-tuber. Until I sent you a report on KSRO, I didn't know there were such things as DX clubs. Two weeks after my name appeared in RADEX, I received three or four sample DX bulletins. I have joined some of the clubs and have had a most enjoyable membership."

## Station NEWS of the Month

The station news of the month, gathered from official sources, includes complete lists of the broadcasting stations in France, Norway, The Netherlands, and Latvia. All this data is correct as of February 10, 1939.

### French Private Stations

- 959 kcs "Poste Parisien," 4 rue du General Foy, Paris. 60000 watts.  
 1068 "Radio Cite," 1 Blvd. Haussmann, Paris. 200 w.  
 1348 "Poste de L'Ile-de-France," 11 rue Christophe Colomb, Paris. 2000 w.  
 913 "Radio Toulouse," 51 rue Alsace-Lorraine, Toulouse. 60000 w.  
 1366 "Radio Sud-Ouest," 2 Cours de Tournon, Bordeaux. 25000 w.  
 1393 "Radio Lyon," 39 rue de Marseille, Lyon. 25000 w.  
 968 "Radio Agen," rue Amoureux, Agen. 2000 w.  
 1303 "Radio Mediterranee," Plateaux Fleuris a Antibes. 25000 w.  
 1095 "Radio Normandie," Villa "La Grandiere," Fecamp. 20000 w.  
 1492 "Radio Nimes," rue des Greffes, Nimes. 2000 w.  
 832 "Radio 37," Compagnie Moderne de Radiodiffusion, 35 rue Francois Ier, Paris. 2000 w.

### French Government Stations

- 182 kcs. "Radio Paris," 11 rue Francois Ier, Paris. 80 kw (will be increased to 150 kw).  
 1456 "Tour Eiffel," Grand Palais, Porte F, Paris. 20 kw.  
 695 "Paris P.T.T.," 103 rue de Grenelle, Paris. 120 kw.  
 1213 "Radio P.T.T.-Nord," 36 Blvd. de la Liberte, Lille. 60 kw.  
 776 "Toulouse-Pyrenees," 50 rue Gambetta, Toulouse. 120 kw.  
 1077 "Bordeaux-Lafayette," 136 rue Ernest Renan, Bordeaux. 60 kw. (Will be increased to 100 kw).  
 749 "Marseille - Provence," 34 rue Croix-de-Regnier, Marseille. 100 kw.  
 648 "Lyon—P.T.T.," 47 rue Gambetta, Lyon. 100 kw.  
 895 "Limoges—P.T.T.," 6 Blvd. Vic-

tor Hugo, Limoges. 500 w. (Will be increased to 100 kw).

- 583 "Alpes-Grenoble," 1 rue Haquelin, Grenoble. 15 kw. (Will be increased to 100 kw).  
 1040 "Renes - Bretagne," Hotel des Postes, Rennes. 120 kw.  
 1339 "Montpellier-Languedoc," 9 Blvd. General Sarraill, Montpellier. 800 w.  
 859 "Radio Strasbourg," 18 rue Nuee-Bleue, Strasbourg. 80 kw.  
 1185 "Nice-Cote d'Azur," 2 Place Grimaldi, Nice. 60 kw.  
 868 "Radio Tunis," Tunis, Tunisia. (transmitter at Djedeida). 20 kw.

### Norwegian Stations

- |                       |     | Kcs. | Watts |
|-----------------------|-----|------|-------|
| (a) Askoy (Bergen)    | LKB | 260  | 20000 |
| Bergen II (local)     | LLE | 355  | 1000  |
| Bodo                  | LKD | 823  | 10000 |
| (b) Bodo              | LKD | 347  | 10000 |
| (b) Finnmark          |     |      |       |
| (Vadso)               | LKI | 347  | 10000 |
| Fredrikstad           | LKF | 1276 | 1000  |
| Hamar                 | LKH | 519  | 700   |
| (c) Kristiansand      | LKK | 629  | 20000 |
| Narvik                | LKG | 1222 | 300   |
| Notodden              | LKN | 1357 | 250   |
| (a) Oslo              | LKO | 260  | 60000 |
| Porsgrunn             | LKP | 850  | 1000  |
| Rjukan                | LKR | 1348 | 150   |
| (d) Stavanger         | LKS | 832  | 10000 |
| Tromso                | LKM | 282  | 10000 |
| (c) Trondelag         |     |      |       |
| (Trondheim)           | LKT | 629  | 20000 |
| (a) Vigra (Alesund) * | LKA | 260  | 10000 |

- (a) Synchronized  
 (b) Synchronized  
 (c) Synchronized  
 (d) Will be replaced by a station of 100,000 watts on 850 kcs.

\* To be increased to 100,000 watts, on 629 kcs.

### Norwegian Shortwave Stations

- 6130 kcs. .... LKJ Oslo 5 kw.  
 9530 kcs. .... LKC Oslo 5 kw.  
 11735 kcs. .... LKQ Oslo 5 kw.  
 15170 kcs. .... LKV Oslo 5 kw.



(Station LKC, Jeloy, on 9530 kcs, has been replaced by the new Oslo station).

**The Netherlands**

At Kootwijk, Hilversum I operate on 160 kcs, using 10 kw. during the day and 120 kw. at night. Owned and operated by the Netherlands government postal authorities.

Hilversum II, at Hilversum, on 722 kcs, is owned and operated by Philips Gloeilampenfabriek of Eindhoven (The Philips Lamp Works).

At Jaarsveld, a station known by that name, operates on 722 kcs, with 20 kw. power. It is operated by Nederlandsche Omroep-Zender Maatschappij (Shortened to NOZEMA).

N. V. Philips operates shortwave stations PCJ, 9590 kcs, and PCJ2, 15220 kcs, both with 60 kw. power; PHI on 11730 kcs with 23.6 kw. power; PH12 on 21480 kcs, with 10 kw. power. This company also has a station at Bloemendaal, on 1220 kcs, with 100 watts.

**Latvia's Stations**

583 kcs. Madona ..... 50 kw.  
 1104 kcs. Kuldiga ..... 50 kw.  
 1258 kcs. Riga ..... 15 kw.  
 1734 kcs. Liepaja ..... 100 watts

**The Vatican**

The Vatican shortwave station now employs frequencies of 6190, 9550, 9660, 11740, 15120 and 17840 kcs. There are three characteristic signals by which the station can be identified. They are, first, a clock, or metronome, beating seconds during the five minutes preceding each broadcast. Second, the bells of St. Peter's chime the hour. Third, each broadcast begins and ends with the words, "Laudetur Jesus Christus."

**Mexico**

Senor Emilio Balli of station XEQ advises us that his station has moved to 730 kilocycles, this frequency having been assigned to them when station XEPN was completely destroyed by fire. XEQ is owned by Radio Panamericana, S. A., Mexico City, D. F., Mexico.

**Cuba**

The new CMX, "La Casa Lavin," has increased power to 15000-20000 watts, and moved to 880 kcs. CMW, formerly on 880, has shifted to 550 kcs, and

CMBD, formerly on 550, changed to 1260 kcs, CMX's former frequency.

The Cuban stations shown in our indices with power of 200 watts, are actually assigned 100-200 watts. We have chosen to show the maximum power allowed. Likewise, we shall show the maximum power for the new CMX.

**QUESTIONS AND ANSWERS**

**Creeping Dial**

*E. H. C., Napa, Calif., I have a Zenith 1938 12-tube receiver. The second-hand of the dial varies more than 5 degrees from previous station positions after the set has warmed up or cooled off.*

*Answer.* Since you say the tuning mechanism is not at fault, this trouble may be caused by "creeping" or "frequency shifting". Changes in the values of the oscillator coils, condensers and tubes may be the cause. Heating and cooling affects the tuning, and this is a "thermal effect." A careful check of the oscillator coils, tubes and associated tuning condenser, by-pass condensers and resistors, should be made by a competent service man. Dampness in the coil may call for a new coil or careful drying and recoating. Try a new oscillator tube, even if the one now used is seemingly in perfect condition.

*F. S., Chicago, Ill. My Zenith 1938 8-tube set gets weak after a few minutes and the target indicator fails to work. Then I have to use the distance switch for locals.*

*Answer.* Have the 6H6G 2nd-detector and a. v. c. tube checked and replaced, even if slightly defective. The radio-frequency stage and tube

(type 6K7G) should be under suspicion also. Defects in the i.f. transformers may give this trouble. And there are several other causes that only a good service man can correct. If the tube above mentioned is good, see a good Zenith authorized service agent who will quickly rectify any transformer trouble.

*J. W. R., Gallion, Ala. I am using a Delco receiver with my 32-volt Delco plant. My receiver is about gone. Can I buy a 110-volt a.c. set, which is cheaper than a 32-volt receiver, and rewire it for 32 volts instead of 110 volts?*

*Answer.* Rewiring any set is a problem because there are so many calculations to be made and units to be removed or replaced. It is far from being practicable, even for an expert. However, since you have only 32 volts available, it might be possible to procure a vibrator unit that will step up your 32 volts to 110 volts a.c. for the operation of a small 5 or 6 tube a.c. set. However, a rotary converter will solve your problem, but at a considerable expense. A new 6-volt farm radio with built-in vibrator is not so costly, and it can be run from only three of the 2-volt units of your lighting system.

*D. C. Wallingford, Conn. I built a wave trap by wrapping 120 turns of uncovered bell wire, No. 24, on a cardboard tube, and placed it in series with the antenna lead to my Zenith radio. But it doesn't work. What is wrong?*

*Answer.* Wind 60 turns of No. 24 insulated wire on a small tube, about  $1\frac{1}{2}$  inches in diameter. Con-

nect a small variable condenser, about .00035 mfd. capacity across the two ends of the coil. Attach one end of the coil to the set and the other to the antenna leadin. Use a single-wire antenna and a ground. Perhaps a careful examination of your set will reveal it to be in need of realignment so that a wave trap may be unnecessary.

*W. G. N., Gettysburg, So. Dak. I have a Goldentone battery set which has a loud hum when used with long battery lead wires. The hum is absent if short wires are used.*

*Answer.* Hum should not develop in this receiver as long as the parts are in good shape. A drop in voltage may cause trouble, and it may be that the long leads from the batteries in your basement insert too much resistance. Use larger wires or increase the battery potential at the source to take care of the voltage drop. It appears that the vibrator is satisfactory since hum is not heard with short leads and proper voltage. However, check the condenser that is shunted across the secondary of the power transformer in the vibrator pack.

*V. H., Chicago, Ill. It would help me to have a complete collection of the wiring diagrams of all modern receivers. How can I get them?*

*Answer.* The Technical Editor would like to have the same collection! However, quite complete sets of radio circuits may be purchased in large loose-leaf book form. These are rather costly. Radio manufacturers, of course, have this data, but it often takes more than a mere appeal to them to get the charts.

# The SHORTWAVE STATIONS and TWENTY STENTORS

● The shortwave list, arranged by frequencies in kilocycles, gives the schedules of the shortwave broadcasting stations. The Twenty Stentors are the shortwave stations which were reported the most frequently in each of the time zones last month. Arranged according to the number of reports received, this chart can be used by new listeners as a guide to the stations which they are most apt to receive in their own localities.

Best in EST	Best in CST	Best in MST	Best in PST	Best in World*
Rome	Berlin	TGWB	TGWB	TGWA
Berlin	Rome	CSW	Paris	Berlin
Paris	Tokyo	VLR3	COCQ	Martinique
London	Paris	TAQ	HAT4	HJ1ABP
VUD2	EAJ43	COBC	VUD3	COJK
XEWW	Martinique	VUD2	Tokyo	LRU
VK3ME	TGWA	VK2ME	London	COCX
Tokyo	TGWB	YV1RB	CB970	Rome
EAQ	HP5A	COCX	VUB2	TAP
VLR	COCM	Rome	TAP	Tokyo
CSW	London	Tokyo	VLR3	VUD3
COCM	HJ1ABP	HP5J	VUD2	COCQ
OZF	TAP	ZRK	VK2ME	Paris
ORK	VUD3	Paris	YV1RB	London
SP25	YV5RC	TGWA	Rome	VUD2
LKC	ZRK	London	HP5J	ZRK
ZRK	PSH	Berlin	ZRK	HP5A
SP19	HVJ	HP5A	TGWA	HVJ
Huizen	HH3W	TI4NRH	Berlin	CSW
HP5A	HP5J	TIEP	HP5A	EAJ43

\*Exclusive of the USA and Canada.

**Time is Eastern Standard. Subtract 1 hour for Central, 2 hours for Mountain and 3 hours for Pacific.**

4107 HCJB	Quito, Ecuador. 7-8:15 am; 11:30 am-2:30 pm; 2:45-10:15 pm. "Broadcasting Provincial," Clarence W. Jones, Casilla 691.	6020 DJC	Berlin, Germany. 50 kw. 1-4:25 pm. See "Berlin" at end of list.
4880 VUC2	Calcutta, India. 10 kw. All India Radio.	6040 TPB16	Paris, France. 25 kw.
4905 VUB2	Bombay, India. 10 kw. All India Radio.	6050 GSA	London, Gt. Britain. 20 kw. 10:45 am-noon; 4:15-6 pm. See "London" at end of list.
4950 VUM2	Madras, India. 10 kw. All India Radio.	6060 W3XAU	Philadelphia, Pa. 10 kw. Su, Tu, W, F, 7:30-11 pm; Su, W, F, 11:30 pm-1 am; M, Tu, Th, midnight-1 am; Sat, 11 pm-2 am. See "W3XAU" at end of list.
4995 VUD2	Delhi, India. 10 kw. All India Radio.	6079 DJM	Berlin, Germany. 50 kw. 4:50-10:50 pm. See "Berlin" at end of list.
5850 YV1RB	Maracaibo, Venezuela. 300 w. 5:45-9:45 am; 3:30-10:45 pm. "Ecos del Zulia," Apartado 37. Relays YV1RA; interval, gong and xylophone, and signs off with "Strike Up The Band."	6080 XEWW	Mexico City, D. F. 10 kw.
5969 HVJ	Vatican City. 15 kw.	6090 TPB15	Paris, France. 25 kw.
5970 YV5RC	Caracas, Venezuela. 1 kw. (Reported on 5910, 5900 and 5973). Weekdays, 7 am-10 pm; Sun, 8:30 am-9:30 pm. "Radio Caracas," Apartado 2009. Relays YV5RA, and signs off with "March 1BC."	6100 YUA	Belgrade, Yugoslavia. 1 kw. 12:45 am-5:30 pm. "Radio Beograd," Bureau Central de Presse, Poste Emetteur a Ondes Courtes. Announcement in Serbian, Italian, English, German, Turkish, Hungarian, Albanian, and Greek.

- 6110 GSL London, Gt. Britain.  
 6120 W2XE New York, N. Y. 10 kw.  
 6122 TGWB Guatemala City, Guat. Experimental.
- 6145 TPB14 Paris, France. 25 kw.  
 6170 W2XE New York, N. Y. Sat, Sun, 11:30 pm-1 am; other days, midnight-1 am. See "W2XE" at end of list.
- 6330 COCW Havana, Cuba. 7 am-midnight. Relays CMW. "La Voz de las Antillas," Apartado 130.  
 6690 TIEP San Jose, Costa Rica. 4-11 pm. (Reported on 6695). "La Voz de Isthmo," Eduardo Pinto H., Apto. 257.  
 7510 JVP Tokyo, Japan. 50 kw. 6-9:30 am. See "Tokyo" at end of list.  
 8664 COJK Camaguey, Cuba. 1 kw. 11:30 am-12:30 pm; 8-10 pm. (Reported on 8660 and 8680). Relays CMJK, "Radio Zenith," Jones Castillon y Cie., Finlay #3.  
 8820 HCJB Quito, Ecuador. 1 kw.  
 9125 HAT4 Budapest, Hungary. 20 kw. Sun, Wed, 7-8 pm; Sat, 6-7 pm. Radiolabor, Kiserleti Allomasa, Gyali-ut 22, Budapest IX.  
 9460 TAP Ankara, Turkey. 20 kw. 11:30 am-5 pm.  
 9480 EAR Madrid, Spain. 20 kw. 7:30-8 pm; 8:30-9 pm. "La Voz de Espana," Medinaclaci 6.  
 9500 XEWW Mexico City, D. F. 10 kw. 8:55 am-midnight. "La Voz de la America Latina desde Mexico." Apto. 2516. Relays XEW, Cadena Radiodifusora Mexicana.  
 9510 GSB London, Gt. Britain. 20 kw. 10:30 am-noon; 1:30-4 pm; 4:15-8:30 pm; 9:20-11:25 pm. See "London" at end of list.  
 VK3ME, Melbourne, Australia. 5 kw. Weekdays, 4-7 am. Amalgamated Wireless, (A/sia), Ltd., 167 King St.  
 9520 OZF Copenhagen, Denmark. 6 kw. 2-6 pm; 10-11 pm. Postog Telegrafvaisenet, Radioingeni-vertjenesten, Bernstorffsgade 32, Copenhagen V.  
 TPB13 Paris, France. 25 kw.  
 9530 LKC Jeloy, Norway. 1 kw. 5-8 am.  
 VUC2 Calcutta, India. 10 kw. 2:06-4:06 am. All India Radio.  
 9535 JZI Tokyo, Japan. 20 kw. 4:30-5:30 pm. See "Tokyo" at end of list.  
 9540 DJN Berlin, Germany. 50 kw. 12:05-11 am; 4:50-10:50 pm. See "Berlin" at end of list.  
 9550 TPB11 Paris, France. 25 kw. 11:15 pm-6 pm. See "Paris" at end of list.  
 9550 VUB2 Bombay, India. 10 kw. 1-3:30 am; 9:30-11:30 pm. All India Radio.  
 9560 DJA Berlin, Germany. 50 kw. 12:05-11 am; 4:50-10:50 pm. See "Berlin" at end of list.
- 9570 TPB11 Paris, France. 25 kw.  
 9580 GSC London, Gt. Britain. 20 kw. 4:15-6 pm; 6-8:30 pm; 9:20-11:25 pm. See "London" at end of list.
- VLR Melbourne, Vic., Australia. 1 kw. 3:15-9:45 am. Robert C. McCall, Manager, Australian Brdcstg. Commission, G.P.O. Box 1686, Melbourne.
- 9590 HP5J Panama City, Panama. 1 kw. (Reported on 9610). 6:30-11 pm. "La Voz de Panama." Apartado 867.  
 PCJ Huizen, Netherlands. 60 kw. Sun, 2-3 pm; Mon, 7:15-8:15 pm; 8:25-9:25 pm; Tu, 1:45-3:30 pm; W, Th, 7-9:30 pm; F, 8-9 pm. Philips' Radio, Emmasingel 29, Eindhoven, Netherlands.  
 VK2ME Sydney, Australia. 20 kw. Sun, 1-3 am; 5-11 am. Signature, laughing notes of kookaburra. Amalgamated Wireless, (A/sia), Ltd., 47 York St.  
 VK6ME Perth, Australia. 5 kw. Weekdays, 6-8 am. Amalgamated Wireless, (A/sia), Ltd.  
 VUD2 Delhi, India. 10 kw. 8:30-10:30 pm. All India Radio.  
 VUD3 Delhi, India. 5 kw. 8:30-10:30 pm. All India Radio.  
 W3XAU Philadelphia, Pa. 10 kw. M, Th, 7:30-11:30 pm; Sat, 7:30-10:45 pm. See "W3XAU" at end of list.  
 9606 ZRK Cape Town, U. of South Africa. 5 kw. Weekdays, 11:45 pm-12:45 am. Programs open with bugle call, and announcement is "Johannesburg Calling." South African Broadcasting Corp., Box 4559, Johannesburg.  
 9618 HJ1ABP Cartagena, Colombia. 750 w. 4:30-10:30 pm. "Radio Cartagena," Apto. 37.  
 9635 2RO3 Rome, Italy. 25 kw. 12:10-10 pm; "Radio Roma-Napoli." Sign off with "Giovinezza" and "Marcha Reale." E.I.A.R., 5 Via Montello.  
 9645 HH3W Port-au-Prince, Haiti. 30 w. 1-2 and 7-8 pm. C. Ricardo Widmaier, Box A-117.  
 9650 W2XE New York, N. Y. Mon thru Fri, 10:30-11:30 pm. See "W2XE" at end of list.  
 9670 COCQ Havana, Cuba. 1 kw. (Reported on 8840, 8700, 8800 and 8850). 9 am-1 am. "de la RCA Victor." Cambo y Gabriel S. A., Calle 25 No. 225, Vedado.  
 9675 DJX Berlin, Germany. 10:35 am-4:25 pm. See "Berlin" at end of list.  
 9684 TI4NRH Heredia, Costa Rica. 500 w. Sun, 7-8 am; Tu, Th, Sat, 9-10 pm. Amando Cspedes Marin, Apartado 40.

9685 TGWA	Guatemala City, Guat. 10 kw. Sun, 7:10:45 pm; Weekdays, 10-11:30 pm. "Voice of Guatemala," Radio-difusion Nacional.	11800 JZJ	Tokyo, Japan. 50 kw. 12:30-1:30 am; 7-9:30 am; 2:30-4 pm; 4:30-5:30 pm; 8-8:30 pm. See "Tokyo."
9700	"Radio Martinique," Fort de France, Martinique. 1500 w. 1:15-2:45 pm; 6-10 pm. Sign off with Marseillaise. Poste Seri, Boite 136.	11810 2RO4	Rome, Italy. 25 kw. 4:40-8:45 am; 11 am-1:09 pm. See "Rome."
9730 CB970	Valparaiso, Chile. (Reported on 9710). 6:30-11 pm.	11820 GSN	London, Gt. Britain.
9830 IRF	Rome, Italy. 20 kw. 12:40-1 pm; 1:37-3:30 pm; 6-9 pm. See "Rome" at end of list.	11830 W2XE	New York, N. Y. 10 kw. Sat, Sun, 6:30-11 pm; Other days, 6:30-10 pm. See "W2XE."
9833 COCM	Havana, Cuba. 1 kw. (Reported on 9805 and 9840). 8 am-10:30 pm. "Trans Radio Columbia," 23 No. 1113, Vedado.	11860 GSE	London, Gt. Britain. 20 kw. 3-5:25 am; 5:45-8:50 am; 9-10:30 am. See "London."
9860 EAQ	Madrid, Spain. "The Voice of Republican Spain," Apartado 951.	11880 VLR3	Melbourne, Australia. 1-3 am. See VLR on 9580 kcs.
9940 CSW	Lisbon, Portugal. 5 kw. (Reported on 9735).	11885 TPA3	Paris, France. 25 kw. 2-5 am; 11:15 am-6 pm. See "Paris."
9960 COBC	Havana, Cuba. (Reported on 9980). 6:55 am-midnight. "El Progreso Cubano," Aptdo 132.	TPB7	Paris, France. 25 kw. 9:30 pm-midnight. See "Paris."
10042 DZB	Berlin, Germany.	12450 HCJB	Quito, Ecuador. Daily exc. Mon, 7:15-10:30 pm.
10220 PSH	Rio de Janeiro, Brazil. 12 kw. Mon, 6-9 pm. Relays PRF4; signs off with Brazilian National Hymn. Cia. Radio Internacional do Brasil, Caixa Postal 709.	15110 DJL	Berlin, Germany. 50 kw. 12:05-2 am; 8-9 am; 10:35 am-4:25 pm. See "Berlin."
10330 ORK	Brussels, Belgium. 11 kw. 1:30-3 pm.	15120 HVJ	Vatican City. 10 kw. 10-10:30 am. Pontificia Accademia Della Scienze, Roma-Castina Pio IV.
10660 JVN	Tokyo, Japan.	15130 TPB11	Paris, France. 25 kw. 2-5 am. See "Paris."
10740 JVM	Tokyo, Japan.	15140 GSF	London, Gt. Britain. 15 kw. 3-5:25 am; 5:45-8:50 am; 9 am-non. See "London."
11040 CSW	Lisbon, Portugal. 5 kw. 2-5:30 pm. "Emisora Nacional".	15160 JZK VUD3	Tokyo, Japan. 50 kw. Delhi, India. 5 kw. 9:30-11:30 pm. All India Radio.
11650 COCX	Havana, Cuba. 1 kw. (Reported on 11740). Sun, 6-9 pm; Weekdays, 8 am-midnight. Relays CMX, "Casa Lavin," Box 32.	XEWW	Mexico City, D. F. 10 kw. "La Voz de la America Latina desde Mexico," Aptdo. 2516.
11660 JVL	Tokyo, Japan.	15170 TGWA	Guatemala City, Guat. 10 kw. Sun, 12:45-1:45 pm; Weekdays, 12:45-5:15 pm. "Voice of Guatemala," Radio-difusora Nacional.
11700 HP5A	Panama City. 300 w. Sun, 9 am-1 pm; 6-10 pm. Weekdays, 11:45 am-1 pm; 6-10 pm. "Radio Teatro Estrella de Panama." Sign off with "Anvil Chorus." Radio Teatro, Aptdo. 954.	15180 GSO	London, Gt. Britain. 3-5:25 am; 4:15-8:30 pm. See "London."
11718 TPB6	Paris, France. 7-9:15 pm. See "Paris."	TAQ	Ankara, Turkey. 20 kw. 9:30-11 am.
TPA4	Paris, France. 7-9:15 pm; 9:30 pm-midnight. See "Paris."	15200 DJB	Berlin, Germany. 8 kw. 8-9 am; 4:50-10:50 pm; Sun only, 11:10 am-12:25 pm. See "Berlin."
11730 PHI	Huizen Netherlands. 23.6 kw. N. V. Philips' Radio, Eindhoven.	15220 PCJ2	Huizen, Netherlands. 60 kw. Tues, 3-4:30 am; Wed, 9:30-11:30 am.
11750 GSD	London, Gt. Britain. 20 kw. 3-5:25 am; 9-10:15 am; 12:20-4 pm; 4:15-8:30 pm; 9:20-11:25 pm. See "London."	15243 TPA2	Paris, France. 25 kw. 6-11 am. See "Paris."
HVJ	Vatican City. Sun, 1-1:30 pm. Pontificia Accademia Della Scienze, Roma-Castina Pio IV.	15260 GSI	London, Gt. Britain. 3-5:25 am; 12:20-1:30 pm.
11760 TGWA	Guatemala City, Guat. 10 kw.	15270 W2XE W3XAU	New York, N. Y. Philadelphia, Pa. 10 kw. 3-7 pm. See "W3XAU."
11770 DJD	Berlin, Germany. 50 kw. 11:30 am-4:25 pm; 4:50-10:50 pm. See "Berlin."	15280 DJQ	Berlin, Germany. 50 kw. Sun, 11:10 am-12:25 pm; Daily, 12:05-11 am; 4:50-10:50 pm. See "Berlin."
		LRU	Buenos Aires, Argentina. 5 kw. 8 am-1 am. "Radio El Mundo," Calle Maipu 555.

15310 GSP	London, Gt. Britain.	1:45-4 pm. See "London."
15340 DJR	Berlin, Germany.	50 kw. 12:05-11 am. See "Berlin."
17760 DJE	Berlin, Germany.	50 kw. 12:05-5:50 am; 6-7:50 am. See "Berlin."
17770 PHI2	Huizen, Netherlands.	23.6 kw. Sun, 6:25-9:40 am; M, Th, 7:40-8:40 am.
17790 GSG	London, Gt. Britain.	5:45-8:50 am; 9 am-noon; 12:20-4 pm. See "London."
17810 GSV	London, Gt. Britain.	5:45-8:50 am; 12:20-4 pm. See "London."
17830 W2XE	New York, N. Y.	
21470 GSH	London, Gt. Britain.	5:45-8:50 am; 9 am-noon. See "London."
21520 W3XAU	Philadelphia, Pa.	10 kw. 1-2:30 pm. See "W3XAU."
21530 GSJ	London, Gt. Britain.	5:45-8:50 am. See "London."
21550 GST	London, Gt. Britain.	
21565 DJJ	Berlin, Germany.	6-7:50 am. See "Berlin."

### Addresses

Berlin—These transmitters are located at Zeesen, near Berlin. Interval signal is the tune, repeated several times, "Ever Be True and Honest," and sign off theme, two national anthems, "Horst Wessel Lied" and "Deutschlandlied". Address is Reichs-Rundfunk G. m. b. H., Haus des Rundfunk, Masurenallee, Berlin-Charlottenberg 9.

London—Transmitters are at Daventry. Interval signals are Bow Bells; Greenwich time signal on even hours; and, irregularly, Big Ben, preceded by Westminster Chimes, strikes the hours. Sign off with "God Save The King." British Broadcasting Corp., London W1.

Tokyo—Transmitters are at Nazaki. Sign off with national anthem, "Kimagayo." Broadcasting Corp. of Japan, Overseas Section, Atago-Yama, Tokyo.

Paris—Transmitters at Essarts-le-Roi. Announce as "Paris Mondial," (Paris Embracing The World), and sign off with "La Marseillaise." Minister of Posts, Telegraphs and Telephones, 98 bis Blvd. Haussmann.

Rome—Stations sign off with "Giovinezza" and "Marcha Reale." E. I. A. R., 5 Via Montello.

W2XE—Transmitters at Wayne Township, N. J. Relay programs of CBS-WABC, and sign off with "Star Spangled Banner." Columbia Broadcasting System, 485 Madison Ave., New York, N. Y.

W3XAU—Transmitters at Newton Square. Relay CBS-WCAU. WCAU Broadcasting Co., 1622 Chestnut St.

## Applications to the FCC

(Only applications which are set for hearing are shown in this list)

KAND, Corsicana, CP 100 (.25) unlt. (Com).
KCMC, Texarkana, CP 1340 kcs, 500 (1) unlt. (C).
KECA, Los Angeles, CP move to San Diego (E).
KEEN, Seattle, CP 1420 kcs, 100 (.25) unlt (E).
KERN, Bakersfield, CP 1380 kcs, 1 kw. (C).
KEX, Portland, CP 1160 kcs, unlt. (E).
KFAB, Lincoln, CP DA night, 1080 kcs, 50 kw unlt.
KFEL, Denver, CP 1 kw. (C).
KFEQ, St. Joseph, CP 500 w. nights, 2500 w. to ss at San Francisco (C).
KFJZ, Fort Worth, CP 930 kcs, 500 w. unlt. DA night (E).
KFSD, San Diego, CP 5 kw. (C).
KGCI, Coeur d'Alene, mod. of CP for 1200 kcs, 100 w. days (C).
KGEC, Sterling, CP move to Denver. (C).
KGNO, Dodge City, CP 500 w. unlt. (C).
KLS, Oakland, CP 1280 kcs, 500 w. unlt. (C).
KMED, Medford, CP 1 kw unlt. (C).
KMJ, Fresno, CP 1000 (5). (C).
KOY, Phoenix, mod. of lic. for 550 kcs. (C).
KPAC, Pt. Arthur, CP 1220 kcs, 500 w. unlt. DA night (E).
KRKO, Everett, CP 100 (.25) unlt. (E).
KRRV, Sherman, CP 880 kcs, 1 kw unlt, DA. (E).
KRSC, Seattle, CP 1 kw. (E).
KTAT, Ft.W orth, CP 1000 (5), and move to Wichita Falls. (E).
KTEM, Temple, mod. of lic. 100 (.25) unlt. (E).
KTKC, Visalia, CP 890 kcs, 1 kw unlt, DA nite (C).
KVOD, Denver, CP 630 kcs, 1 kw. (C).
WALA, Mobile, CP 1 kw unlt. (C).
WAZL, Hazelton, mod. lic. 1320 kcs, 100 w. unlt. (E).
WBAX, Wilkes Barre, renewal of lic. set for hearing (C).
WBNX, New York, CP 5 kw, move trans. to Carlstadt, N. J. (C).
WCBS, Springfield, Ill., CP 1290 kcs, 1 kw. (C).
WDAE, Tampa, mod. lic. 780 kcs, (E. rec. denial). (C).
WDAN, Danville, mod. lic. for 100 (.25) unlt. (E).
WDEL, Wilmington, mod. of CP for 1 kw. (E).
WDGY, Minneapolis, mod. of lic. for unlt. (C).
WEDC, Chicago, CP 100 (.25) specified hrs. (C).
WEXL, Royal Oak, SP 1300 kcs, 250 w. (E).
WFIL, Philadelphia, CP 1000 (5) unlt. (E).
WFMD, Frederick, CP 500 w. unlt, DA nite (C).
WGRC, New Albany, CP 880 kcs, 250 w. unlt, DA nite (E).
WGTM, Wilson, CP 1240 kcs, 500 w. (E).
WHAI, Greenfield, mod. of lic. 100 (.25) unlt. (E).
WHLS, Port Huron, mod. of lic. 100 (.25) unlt. (C).
WIP, Philadelphia, CP 5 kw, move trans. to Brooklawn, N. J., DA (E).
WIRE, Indianapolis, mod. of CP for 5 kw, (E).

WIS, Columbia, spec. exp. authority for new satellite station at Sumter, S. C., 560 kcs, 10 to 100 w. from LS to sunrise (E).  
 WJAC, Johnstown, mod of lic. 1370 kcs, 100 (.25) unlt'd (E).  
 WJBW, New Orleans, mod. of lic. unlt'd. (C).  
 WJRD, Tuscaloosa, mod. of lic. for 100 (.25) unlt'd. (C).  
 WKOK, Sunbury, mod. of lic. unlt'd. (C).  
 WLAC, Nashville, CP 50kw. (E).  
 WLAW, CP DA nite, 1 kw to ss at San Francisco (C).  
 WMBC, Detroit, CP 600 kcs, 250 w. unlt'd. (E).  
 WMBR, Jacksonville, CP 1120 kcs, 500 (1). (E).  
 WMFF, Plattsburg, CP 1240 kcs, DA, 1 kw. (E).  
 WMIN, St. Paul, mod. lic. 250 w. unlt'd. (C).  
 WPG, Atlantic City, CP unlt'd, move studio to New York, trans. to Kearney, N. J., requesting facilities of WBIL and wOV. CP change owner to Greater N. Y. Brdcastg. Corp. (E).  
 WPRM, Mayaguez. CP 780 kcs, 1000 (2.5) unlt'd. (E).  
 WRAW, Reading, CP 250 w. (C).  
 WRBL, Columbus, CP 1330 kcs, 1 kw. (C).  
 WRR, Dallas, CP 1 kw (E).  
 WSFA, Montgomery, CP 1410 kcs, 1 kw unlt'd. (E).  
 WSJS, Winston Salem, CP 100 (.25) (E).  
 WSNJ, Bridgeton, CP 100 (.25) unlt'd (C).  
 WTAQ, Green Bay, Wis. CP 1000 (5). (C).  
 WTAR, Norfolk, CP 5 kw. (E).  
 WTEL, Philadelphia, mod. of lic. to share with WHAT (E).  
 WTHT, Hartford, CP 100 (.5). (C).  
 WTMV, E. St. Louis, mod. of lic. 250 w. (E).  
 WTOLO, Toledo, mod. of lic. unlt'd. (E).

### Applications For New Stations

Akron, Ohio, Summit Radio Corp., 1530 kcs, 1 kw unlt'd. (E).  
 Ashland, Wis., WJMS, Inc., 1370 kcs, 100 w. unlt'd. (C).  
 Asheville, N. C., Asheville Daily News, 1370 kcs, 100 w. unlt'd. (C).  
 Asheville, N. C., Publix Bamford Theaters, 1430 kcs, 500 (1). (E).  
 Birmingham, Ala., Birm. News Co., 590 kcs, 1 kw. (C).  
 Bowling Green, Ky., B. G. Brdcastg. Co., 1310 kcs, 100 (.25). (C).  
 Cleveland, Ohio, Cuyahoga Valley Brdcastg. Co., 1500 kcs, 100 w. days. (E).  
 Dalhart, Texas, Dalhart Brdcastg. Co., 1500 kcs, 10w (.25) (C).  
 Elgin, Ill., Elgin Brdcastg. Ass'n., 1170 kcs, 100 w. days (E).  
 Elizabeth City, N. C., 1370 kcs, 100 (.25) (E).  
 Ely, Wyo., Eastern Nev. Brdcastg. Co., 1500 kcs, 100 w. days (E).  
 Erie, Pa., Presque Isle Brdcastg. Co., 1500 kcs, 100 (.25) (E).  
 Evanston, Ill., Northwestern Brdcastg. Assn., 1310 kcs, 100w. (E).  
 Everett, Wash., Cascade Brdcastg. Co., 1420 kcs, 100 (.25) (E).

Florence, S. C., Pee Dee Brdcastg. Co., 1200 kcs, 100 (.25) (requests facilities of WOLS) (E).  
 Fremont, Nebr., Nebr. Brdcastg. Corp., 1370 kcs, 100 (.25) (E).  
 Grants Pass, Ore., Southern Ore. Brdcastg. Co., 1310 kcs, 100 w. unlt'd. (C).  
 Hastings, Nebr., South Nebr. Brdcastg. Co., 920 kcs, 1000 (5) (E).  
 Kingston, N. Y., Kingston Brdcastg. Corp., 1500 kcs, 100 w. days.  
 Louisville, Ky., Gateway Brdcastg. Co., 880 kcs, 500 w. (C).  
 Louisville, Ky., Ky. Brdcastg. Corp., 1210 kcs, 100 (.25) (C).  
 Mansfield, Ohio, Richland, Inc., 1370 kcs, 250 w. days (E).  
 Marinette, Wis., M & M Brdcastg. Co., 570 kcs, 250 w. days (C).  
 Martinsville, Va., Mart'le Brdcastg. Co., 1420 kcs, 100 (.25) (C).  
 Marysville, Calif., Yuba-Sutter Broadcasters, 1320 kcs, 250 w. (C).  
 McComb, Miss., McComb Brdcastg. Corp., 1200 kcs, 100 w. days (E).  
 Modesto, Calif., Thomas McTammany, 1340 kcs, 500 w. (C).  
 Modesto, Calif., Wm. H. Bates, 740 kcs, 250 w. days (facilities of KTRB) (E).  
 Montebello, Calif., Bureau of Education, 1420 kcs, 100 w. days (contingent upon KECA's move to San Diego). (C).  
 Niagara Falls, N. Y., 1260 kcs, 1 kw. (C).  
 Norfolk, Va., Colonial Brdcastg. Corp., 1370 kcs, 100 (.25) (C).  
 North Sacramento, Calif., 1420 kcs, 100 w. days (C).  
 Ocala, Fla., John Alsop, 1500 kcs., 100 w. (E).  
 Ogdensburg, N. Y., St. Lawrence Brc. Corp., 1310 kcs, 100 (.25) (C).  
 Olney, Ill., Olney Brc. Co., 1210 kcs, 100 (.25) (E).  
 Phoenix, Ariz., M. C. Reese, 1200 kcs, 100 (.25) (E).  
 Pontiac, Mich., King-Trendle Brdc. Corp., 1440 kcs, 250 w. (C).  
 Pontiac, Mich., Pontiac Brc. Co., 1100 kcs, 1 kw days. (C).  
 Pontiac, Mich., Geo. B. Storer, 600 kcs, 500 (1). (C).  
 Proctorville, Ohio, David F. Thomas, CP spec. em. station, 2726 kcs, 5 w., in addition to anyone of 3 freqs. 31420, 39660, 39860 kcs, 15 w.  
 Providence, R. J., Peter J. Calderone, 1270 kcs, 250 w. days. (E. rec. denial). (C).  
 Rochester, N. Y., Edward J. Doyle, 1270 kcs, 500 w. days. (E).  
 Rockville, Md., Monocacy Brc. Co., 1140 kcs, 250 w. days (C).  
 Saginaw, Mich., Saginaw Brc. Co. Co., 950 kcs. (C).  
 Sandusky, Mich., Thumb Brc. Co., 880 kcs, 1 kw days. (E).  
 San Juan, P. R., United Theaters, Inc., 580 kcs, 1000 w. (C).  
 San Juan, P. R., E. R. Sanfeliz, 580 kcs., 1 kw. (C).

(E) indicates the application is set for hearing before an Examiner. (C) indicates it is set for hearing before the Commission. freq (frequency); mod (modification); lic (license); pwr (power); ltd (limited time); unlt'd (unlimited time); CP (construction permit); hrs (hours); trans (transmitter); exp (experimental); ss (sunset); LS (local sunset); DA (directional aerial).

Santa Monica, Calif., A. E. Austin, 1160 kcs, 100 (.25) (C).  
 Sedalia, Mo., Drohlich Bros., 1500 kcs, 100 (.25) (E).  
 Springfield, Ohio, S. Brc. Corp., 1310 kcs, 100 w. (E).  
 Suffolk, Va., S. Brc. Corp., 1420 kcs, 100 (.25) (C).  
 Sumter, S. C., J. Samuel Brody, 1310 kcs, 100 (.25) (E).  
 Sweetwater, Tex., 1210 kcs, 250 w. days (E).  
 Tacoma, Tacoma Brc. Co., 1420 kcs, 100 (.25) (E).  
 Tacoma, Michael J. Mingo, 1400 kcs, 250 w. (E).  
 Vincennes, Ind., Vin. Newspapers, Inc., 1420 kcs., 100 w. (C).  
 Washington, D. C., Lawrence J. Heller, 1310 kcs, 100 (.25) (Facilities of WOL) (C).  
 Washington, D. C., Lawrence J. Heller, synchronous station on 1310 kcs, 10 to 100 w. unlt'd, to be used with above station if application is granted (C).  
 Worcester, Mass., Central Brc. Corp., 1500 kcs, 100 (.25) (C).

**Applications, listed here last month, which have been withdrawn or denied.**  
 Metuchen, N. J., Bernard Goldsmith, 1420 kcs, 100 w. days (E).  
 San Francisco, Calif., Larry Rhine, 1420 kcs, 100 w. (facilities of KSAN) (E).  
 Tupelo, Miss., Julius H. Dixon, 1500 kcs, 100 (.25) Facilities of WHEF. (C).

1080 CMBX Havana, Cuba, 200 from 150.  
 1080 CMKM Manzanillo, Cuba, 200 from 100.  
 1090 XERB Rosarito Beach, B. Cfa., 150000 from 100000.  
 1140 CMBC Havana, Cuba, 200 from 150.  
 1150 CMKG Santiago, Cuba, 200 from 100.  
 1150 XEDW Minatitlan, Ver., 300 from 20.  
 1160 CMHJ Cienfuegos, Cuba, 200 from 100.  
 1170 CMBS Havana, Cuba, 200 from 150.  
 1190 CMKX Santiago, Cuba, 200 from 75.  
 1200 CMCO Havana, Cuba, 200 from 150.  
 1210 CMHK Cruces, Cuba, 200 from 250.  
 1230 CMCB Havana, Cuba, 200 from 150.  
 1250 CMKC Santiago, Cuba, 200 from 150.  
 1310 XEX Monterrey, N. L., 500 from 125.  
 1380 CMCW Havana, Cuba, 200 from 150.  
 1400 CMKR Santiago, Cuba, 200 from 100.  
 1430 KSO Des Moines, Iowa, 1000 (5) from 500 (2.5).  
 1450 CMHM Cienfuegos, Cuba, 200 from 150.  
 1470 CMGX Havana, Cuba, 200 from 150.  
 1480 CMHX Cienfuegos, Cuba, 200 from 120.  
 1530 CMC Havana, Cuba, 200 from 150.

**Location**

1340 XEXD Orizaba, Ver., from Jalapa.

**Network**

580 KCUA Edmonton, Alta., new CBC.  
 1010 CKWX Vancouver, B. C., new CBC.  
 1180 WDGY Minneapolis, Minn., new MBS.  
 1200 KOOS Marshfield, Ore., new MBS.  
 1210 WCOU Lewiston, Maine, new MBS.  
 1210 WHAI Greenfield, Mass., new MBS.  
 1370 KRKO Everett, Wash., new MBS.  
 1500 KXO El Centro, Calif., new MBS.

**Delete**

1200 KDNC Lewistown, Mont.

**Permit to Change Power**

580 WILL Urbana, Ill., to 5000.  
 590 WKZO Kalamazoo, Mich., to 250 (1).  
 760 KXA Seattle, Wash., to 1000.  
 770 KFAB Lincoln, Nebr., to 50000.  
 850 WKAR E. Lansing, Mich., to 5000.  
 850 WWL New Orleans, La., to 50000.  
 880 CMW Havana, Cuba, to 5000.  
 880 WRNL Richmond, Va., to 1000.  
 890 KFNF Shenandoah, Iowa, to 1000 (5).  
 900 KGBU Ketchikan, T. A., to 1000.  
 1020 WDJ Tuscola, Ill., to 1000.  
 1040 KRLD Dallas, Texas, to 50000.  
 1110 WRVA Richmond, Va., to 50000.  
 1190 WATR Waterbury, Conn., to 250.  
 1250 KIT Yakima, Wash., to 500 (1).  
 1350 KWK St. Louis, Mo., to 5000.  
 1370 KAST Astoria, Ore., to 100 (.25).  
 1370 KSLM Salem, Ore., to 500.  
 1400 KLO Ogden, Utah, to 1000 (5).  
 1430 WHP Harisbug, Pa., to 1000 (5).  
 1460 KSTP St. Paul, Minn., to 50000.  
 1460 WJSV Washington, D. C., to 50000.  
 1490 WCKY Covington, Ky., to 50000.

**Permit to Change Frequency**

770 KFAB Lincoln, Nebr., to 1080.  
 1190 WATR Waterbury, Conn., to 1290.  
 1370 KAST Astoria, Ore., to 1200.  
 1370 KSLM Salem, Ore., to 1360.

**The Month's Changes in Station Data**

**New**

1340 XEBW Chihuahua, Chih.  
 1370 WBTH Williamson, W. Va.  
 1380 XEM Chihuahua, Chih.  
 1430 XERH Mexico City, D. F.  
 1490 XECH Toluca, Mex.  
 1500 WRKL Rock Hill, S. C.

**Frequency**

590 CMCY Havana, Cuba, from 570.  
 770 CMKW Santiago, Cuba, from 750.

**Power**

660 CMCR Havana, Cuba, 200 from 150.  
 720 CMK Havana, Cuba, 200 from 250.  
 750 CMBL Havana, Cuba, 200 from 500.  
 780 CMCU Havana, Cuba, 200 from 150.  
 850 CMCM Havana, Cuba, 200 from 250.  
 850 WWL New Orleans, La., 50000 from 10000.  
 860 CMJA Camaguey, Cuba, 200 from 250.  
 890 WMMN Fairmont, W. Va., 1000 (5) from 500 (1).  
 910 CMOA Havana, Cuba, 200 from 250.  
 980 XEAC Tijuana, B. Cfa., 5000 from 1000.  
 1000 XEBI Aguascalientes, Ags., 250 from 25.  
 1060 CMHI Santa Clara, Cuba, 200 from 250.



NORTH AMERICAN B. C. STATIONS BY FREQUENCIES  
WITH WEEKDAY TIME ON THE AIR

KEY TO SYMBOLS

As shown in the Index by Frequencies

Frequencies are given in kilocycles per second, and wavelengths in meters. Night power is shown in watts in third column. Daytime power is shown in parentheses in fourth column, in kilowatts. Thus: (25) indicates 250 watts. Exact frequencies, when not multiples of ten, are shown in the fourth column.

Second Column Symbols

- a Verifies for return postage.
- b Verifies only occasionally.
- c Does not verify.
- d Verifies — no postage required.
- e Verifies for International Reply Coupon
- f Verifies for 10 cents.
- g Card for postage; veri stamp for 10c.
- z No information available.

Fourth Column Symbols

- A Status in doubt.
- B National "Blue" Network.
- C Columbia Network.
- D Daytime only.
- F Canadian Network.

- G Assigned this frequency but using another under Special Authorization.
- H Assigned another frequency —using this one under Special Authorization.
- J Assigned lower power but using this power under Special Authorization.
- K Licensed for facsimile.
- L Limited time.
- M Mutual Network.
- N National "Red" and "Blue" Networks.
- P Has Construction Permit only.
- Q Station not in use.
- R National "Red" Network.
- S Sundays only.
- Sy Synchronized.
- X Has Permit to change power
- Y Has Permit to change location.
- Z Has Permit to change frequency.
- a-b-c Small letters show stations using same transmitter.
- 1-2-3 Figures denote stations sharing time.
- ? Reported but not officially confirmed.
- ... No information.

LS means Local Sunset, and always refers to sunset at the transmitter.

540 kcs. (555.2 m.)



EASTERN STANDARD TIME

CBK	z	5000	P	Saskatoon, Sask.	
CJRM	a	1000	F	Regina, Sask.	9:30 am-1:30 am.
ZNS	d	400	....	Nassau, Bahamas	

550 kcs. (545.1 m.)



CFNB	a	500	F(1)	Fredericton, N. B.	
CMBD	z	200	....	Havana, Cuba	
KFUO	a	500	2(1)	St. Louis, Mo.	8-9 am; 10:30-10:45 am; 1:15-1:45 pm; 4-4:45 pm.
KFYR	a	1000	N(5)	Bismarck, N. Dak.	8 am-1 am.
KOAC	a	1000	....	Corvallis, Ore.	noon-midnight.
KSD	a	1000	2R(5)	St. Louis, Mo.	
KTSA	a	1000	C(5)	San Antonio, Tex.	
WDEV	a	500	D	Waterbury, Vt.	7 am-LS.
WGR	a	1000	C(5)	Buffalo, N. Y.	
WKRC	a	1000	C(5)	Cincinnati, Ohio	6:30 am-2 am.
WSVA	a	500	D	Harrisonburg, Va.	6:30 am-5 pm.

560 kcs. (535.4 m.)



KFDM	a	500	N(1)	Beaumont, Texas	
KLZ	a	1000	C(5)	Denver, Colo.	8 am-2 am.
KSFO	a	1000	C(5)	San Francisco, Calif.	9:10 am-3 am.
KWTO	a	5000	D	Springfield, Mo.	
WFIL	a	1000	BMJ	Philadelphia, Pa.	7 am-12:30 am.
WIND	a	1000	(5)	Gary, Ind.	7 am-5 am.
WIS	a	1000	N(5)	Columbia, S. C.	6:45 am-midnight.
WQAM	a	1000	C	Miami, Fla.	6:30 am-midnight.

570 kcs. (526 m.)



KGKO	a	1000	B(5)	Ft. Worth, Texas	
KMTR	a	1000	....	Los Angeles, Calif.	8 am-2 am.
KVI	a	1000	C(5)	Tacoma, Wash.	9 am-3 am.
WKBN	a	500	1C	Youngstown, Ohio	
WMCA	a	1000	....	New York, N. Y.	
WNAX	a	1000	C(5)	Yankton, S. Dak.	
WOSU	a	750	1(1)	Columbus, Ohio	MTWTF, 9-11 am; MTWT, 1-3 pm; M, 8-10 pm; W, 8-11 pm.
WSYR	a	1000	Ba	Syracuse, N. Y.	6 am-1 am.
WSYU	a	1000	Qa	Syracuse, N. Y.	
WWNC	a	1000	N	Asheville, N. C.	

## Monday Thru Friday

## Eastern Standard

## 580 kcs. (516.9 m.)

CKPR	a	100	...	Prince Rupert, B. C.	
CHRC	a	100	...	Quebec, P. Q.	7:30 am-midnight.
CKCL	a	100	F	Toronto, Ont.	7:30 am-12:30 am.
CKPR	a	1000	...	Fort William, Ont.	8 am-11:30 pm.
CKUA	c	500	F	Edmonton, Alta.	MTWTF, 1:30-3 pm; Th, 4-5 pm; M, 4-5:15 pm; TWF, 4-5:30 pm; MTF, 7-10:15 pm; Th, 7-10:30 pm; W, 7 pm-midnight.
KMJ	a	1000	KN	Fresno, Calif.	
KSAC	a	500	2(1)	Manhattan, Kans	10:30-11:30 am; 1:30-3 pm; 5:30-6:30 pm.
WCHS	a	500	C(1)	Charleston, W. Va	6 am-1 am.
WDBO	a	1000	C(5)	Orlando, Fla.	7 am-12:05 am.
WIBW	a	1000	C2(5)	Topeka, Kans.	5:30-10:30am; 11:30 am-1:30 pm; 3:30 pm-1 am.
WILL	a	1000	DX	Urbana, Ill.	8:30 am-LS.
WTAG	a	1000	R	Worcester, Mass.	7:30 am-midnight.
XEMU	z	250	....	Piedras Negras, Coah.	

## 590 kcs. (508.2 m.)

CMCY	a	15000	....	Havana, Cuba	
KHQ	a	1000	R(5)	Spokane, Wash.	9:45 am-3 am.
WEEI	a	1000	C(5)	Boston, Mass.	6:30 am-1 am.
WKZO	a	1000	BDX	Kalamazoo, Mich.	7 am-5:15 pm.
WOW	a	1000	R(5)	Omaha, Nebr.	6:45 am-2 am.

## 600 kcs. (499.7 m.)

CFCF	a	500	BF	Montreal, P. Q.	7:45 am-1 am.
CJOR	a	500	....	Vancouver, B. C.	10 am-3 am.
FQN	a	250	609	St. Pierre, Miquelon	
KFSO	a	1000	B	San Diego, Calif.	10 am-3 am.
WCAO	g	500	C(1)	Baltimore, Md.	7 am-midnight.
WICC	f	500	BM(1)	Bridgeport, Conn.	6 am-1:30 am.
WMT	a	1000	BM(5)	Cedar Rapids, Iowa	
WREC	a	1000	C(5)	Memphis, Tenn	

## 610 kcs. (491.5 m.)

CHNC	a	1000	F	New Carlisle, P. Q.	7 am-11:15 pm.
KFAR	z	1000	P	Fairbanks, Alaska	
KFRC	b	1000	M(5)	San Francisco, Calif.	
WCLE	a	500	DM	Cleveland, Ohio	6:45 am-LS.
WDAF	a	1000	R(5)	Kansas City, Mo.	7 am-1 am.
WIOD	a	1000	Na	Miami, Fla.	MTTF, 6:45 am-midnight; W, 6:45 am-1 am.
WIP	a	1000	....	Philadelphia, Pa.	
WMBF	a	1000	Qa	Miami, Fla.	

## 620 kcs. (483.6 m.)

KGW	a	1000	R(5)	Portland, Ore.	
KTAR	a	1000	N	Phoenix, Ariz.	
KWFT	z	250	(1)P	Wichita Falls, Tex.	
TIPG	z	2000	625	San Jose, Costa Rica	
WFLA	a	1000	Na(5)	Tampa, Fla.	MWF, 7 am-1 am.
WHJB	a	250	CD	Greensburg, Pa.	
WLBZ	a	500	MN(1)	Bangor, Maine	
WSUN	a	1000	Na(5)	St. Petersburg, Fla.	TThSat, 7:55 am-1 am.
WTMJ	a	1000	N(5)	Milwaukee, Wis.	

## 630 kcs. (475.9 m.)

CFCO	a	100	F	Chatham, Ont.	7:30 am-1:30 pm; 4:30-10:30 pm.
CFCY	a	1000	F	Charlottetown, P.E.I.	
CJRC	a	1000	F	Winnipeg, Man.	8:30 am-2 am.
CKOW	a	100	F	Kelowna, B. C.	7 am-2 am.
CMCD	a	15000	....	Havana, Cuba	
KFRU	a	500	1(1)	Columbia, Mo.	M, 7 am-9:30 pm; TWT, 7 am-1 am; F, 7 am-6:30 pm.
KGFX	a	200	D	Pierre, S. Dak.	

**Monday Thru Friday**

**Eastern Standard**

WGFB	a	500	N(1)	Evansville, Ind.	M, 7:30 am-8:30 pm; 9:30-1 am; T Th, 7 am-8 pm; W, 7:30 am-8 pm; F, 7:30 am-1 am.
WMAL	a	250	B(.5)	Washington, D. C.	
WPRO	a	500	C(1)	Providence, R. I.	6 am-1 am.
XEZ	a	500	....	Merida, Yuc.	11 am-2:30 pm; 7:15 -11 pm.

**640 kcs. (468.5 m.)**

KFI	f	50000	R	Los Angeles, Calif.	10 am-3 am.
WGAN	a	500	D	Portland, Me.	7 am-3 hrs after LS.
WHKC	a	500	ML	Columbus, Ohio	6:30 am-8:30 pm.
WOI	a	5000	D	Ames, Iowa	7:30 am-LS.
XEBX	z	250	....	Sabinas, Coah.	
YSS	a	500	....	San Salvador, E. S.	

**650 kcs. (461.3 m.)**

TIX	z	1000	....	San Jose, Costa Rica	
WSM	a	50000	KMN	Nashville, Tenn.	

**660 kcs. (454.3 m.)**

CMCR	z	200	....	Havana, Cuba	
WAAW	a	500	D	Omaha, Nebr.	7 am-6 pm.
WEAF	a	50000	R	New York, N. Y.	6:30 am-1 am.
XEAL	z	1000	A	Mexico City, D. F.	
XEAO	a	250	....	Mexicali, B. Cfa.	

**670 kcs. (447.5 m.)**

WMAQ	c	50000	R	Chicago, Ill.	8 am-2 am.
------	---	-------	---	---------------	------------

**680 kcs. (440.9 m.)**

CMHW	f	200	....	Santa Clara, Cuba	8 am-noon; 3-11 pm.
KFEQ	a	2500	D	St. Joseph, Mo.	
KPO	a	50000	R	San Francisco, Calif.	
VAS	f	2000	685	Glace Bay, N. S.	noon and 11 pm.
VOWR	c	500	681	St. John's, Nfld.	
WLAW	a	1000	D	Lawrence, Mass.	7 am-LS.
WPTF	a	5000	N	Raleigh, N. C.	6:30 am-11 pm.

**690 kcs. (434.5 m.)**

CMBG	a	200	...	Havana, Cuba	
CFRB	a	10000	C	Toronto, Ont.	7:30 am-midnight.
CJ CJ	a	100	F	Calgary, Alta.	9 am-1 am.
XET	a	5000	....	Monterrey, N. L.	

**700kcs. (428.3 m.)**

WLW	a	500000	JKMN	Cincinnati, Ohio	5:45 am-2 am.
-----	---	--------	------	------------------	---------------

**710 kcs. (422.3 m.)**

CMKS	a	200	....	Guantanamo, Cuba.	9 am-11 pm.
KIRO	a	1000	CHJ	Seattle, Wash.	
KMPC	a	500	L	Beverly Hills, Calif.	
WOR	a	50000	KM	Newark, N. J.	6:25 am-1:30 am.
XEQ	a	50000	....	Mexico City, D. F.	

**720 kcs. (416.4 m.)**

CMK	a	200	....	Havana, Cuba.	
TIGH	z	600	725	San Jose, Costa Rica	
WGN	a	50000	KM	Chicago, Ill.	
XEH	a	250	....	Monterrey, N. L.	

**730 kcs. (410.7 m.)**

CFPL	a	100	F	London, Ont.	
CJCA	a	1000	F	Edmonton, Alta.	8:30 am-2 am.

## Monday Thru Friday

## Eastern Standard

CKAC	a	5000	C	Montreal, P. Q.
XELO	a	50000	....	Tijuana, B. Cfa.
XEPN	a	100000	A	Piedras Negras, Coah.

## 740 kcs. (405.2 m.)

CMJX	z	200	....	Camaguey, Cuba	
KMMJ	a	1000	D	Clay Center, Nebr.	
KTRB	a	250	D	Modesto, Calif.	
WHEB	a	250	D	Portsmouth, N. H.	7 am-LS at Atlanta
WSB	a	50000	R	Atlanta, Ga.	

## 750 kcs. (399.8 m.)

CMBL	a	200	....	Havana, Cuba	
KGU	a	2500	LN	Honolulu, Hawaii	11:30 am-4:30 am.
WJR	a	50000	C	Detroit, Mich.	
XEAA	a	200	....	Mexicali, B. Cfa.	
XEAM	z	25	....	Matamoros, Tams.	

## 760 kcs. (394.5 m.)

KXA	a	250	(.5)X	Seattle, Wash.	
WBAL	a	2500	BMSy	Baltimore, Md.	
WCAL	a	1000	2(5)	Northfield, Minn.	7:30-11:30 am; 1:30-2:30 pm.
WEW	a	1000	D	St. Louis, Mo.	7 am-LS.
WJZ	a	50000	BSy	New York, N. Y.	6:30 am-1 am.
WLB	a	1000	2(5)	Minneapolis, Minn.	

## 770 kcs. (389.4 m.)

CMKW	z	200	....	Santiago, Cuba	
KFAB	a	10000	CSyXZ	Lincoln, Nebr.	
TILJ	z	500	775	San Jose, Costa Rica	
WBBM	a	50000	CSy	Chicago, Ill.	

## 780 kcs. (384.4 m.)

CHWK	f	100	F	Chilliwack, B. C.	11 am-midnight.
CKSO	a	1000	F	Sudbury, Ont.	7:45 am-midnight.
CMCU	a	200	....	Havana, Cuba	
KEHE	a	1000	(5)	Los Angeles, Calif.	
KFDY	a	1000	D	Brookings, S. Dak.	
KFQD	c	250	....	Anchorage, Alaska	
KGHL	a	1000	N(5)	Billings, Mont.	
KWLK	a	250	D	Longview, Wash.	10 am-LS.
WEAN	a	1000	BM(5)	Providence, R. I.	
WMC	a	1000	R(5)	Memphis, Tenn.	7 am-1 am.
WPIC	a	250	D	Sharon, Pa.	6:30 am-LS.
WTAR	g	1000	N	Norfolk, Va.	6:30 am-1 am.
XEN	a	1000	....	Mexico City, D. F.	

## 790 kcs. (379.5 m.)

CMGH	a	200	....	Matanzas, Cuba	
KGO	a	7500	B	San Francisco, Calif.	
KOAM	a	1000	DN	Pittsburg, Kans.	7 am-LS.
WGY	a	50000	R	Schenectady, N. Y.	6:45 am-1 am.

## 800 kcs. (374.8 m.)

HIX	a	800	....	Ciudad Trujillo, D. R.	
TIXD	z	1000	....	San Jose, Costa Rica	
WBAP	a	50000	Na	Fort Worth, Tex.	6:45-8 am; 9:30-11:30 am; 1:30-4 pm; 6:30-7:30 pm; 8-11 pm.

**Monday Thru Friday**

**Eastern Standard**

WFAA	a	50000	Na	Dallas, Texas	8-9:30 am; 11:30 am-1:30 pm; 4-6:30 pm; 7:30-8 pm.
WTBO	a	250	D	Cumberland, Md.	7:30 am-6:30 pm.

**810 kcs. (370.2 m.)**

CMCF	a	5000		Havana, Cuba	8 am-midnight.
WCCO	g	50000	C	Minneapolis, Minn.	7 am-1 am.
WNYC	a	1000	D	New York, N. Y.	
XEBZ	a	100	....	Mexico City, D. F.	
XEDF	a	100	....	Nuevo Laredo, Tams.	

**820 kcs. (365.6 m.)**

WHAS	a	50000	C	Louisville, Ky.	
XEBG	z	1000	....	Tijuana, B. Cfa.	

**830 kcs. (361.2 m.)**

KOA	a	50000	R	Denver, Colo.	
WEEU	a	1000	DR	Reading, Pa.	
WHDH	a	1000	L	Boston, Mass.	
WRUF	a	5000	L	Gainesville, Fla.	

**860 kcs. (348.6 m.)**

CBL	a	50000	F	Toronto, Ont.	7:45 am-12:30 am.
CFQC	a	1000	F	Saskatoon, Sask.	
VOGY	a	400	....	St. Johns, Nfld.	
XERA	a	250000	....	Villa Acuna, Coah.	

**850 kcs. (352.7 m.)**

CMCM	a	200	....	Havana, Cuba	
KIEV	a	250	D	Glendale, Calif.	
WESG	a	1000	CDH	Elmira, N. Y.	7:30 am-LS at New Orleans.
WKAR	a	1000	DX	E. Lansing, Mich.	7 am-5 pm.
WWL	a	50000	CJX	New Orleans, La.	

**860 kcs. (348.6 m.)**

CMJA	a	200	....	Camaguay, Cuba.	
WABC	a	50000	Ca	New York, N. Y.	
WBOQ	a	50000	Qa	New York, N. Y.	
WHB	a	1000	DM	Kansas City, Mo.	
XEMO	a	5000	....	Tijuana, B. Cfa.	

**870 kcs. (344.6 m.)**

WENR	c	50000	Ba	Chicago, Ill.	4-7:30 pm; 9 pm-2 am.
WLS	a	50000	Ba	Chicago, Ill.	
XEFB	a	200	....	Monterrey, N. L.	
XERC	z	500	A	Mexico City, D. F.	

**880 kcs. (340.7 m.)**

CBO	a	1000	F	Ottawa, Ont.	
CFJC	a	1000	F	Kamloops, B. C.	7 am-midnight.
CMW	e	1400	X	Havana, Cuba	7:30-9:15 am; 11 am-4:30 pm; 6:30-8:30 pm; 10:30 pm-2 am.
KFKA	a	500	2M(1)	Greeley, Colo.	
KLX	a	1000	....	Oakland, Calif.	
KPOF	a	1000	2	Denver, Colo.	9:15-10:45 am; 4:30-6:30 pm; 8:30-10:30 pm.
KVAN	z	250	DP	Vancouver, Wash.	
TILS	z	1000	....	San Jose, Costa Rica	

## Monday Thru Friday

## Eastern Standard

WCOC	a	1000	C	Meridian, Miss.	
WGBI	f	500	C1(1)	Scranton, Pa.	7 am-1 am.
WQAN	a	500	1(1)	Scranton, Pa.	
WRNL	a	500	DX	Richmond, Va.	6 am-LS.
WSUI	a	500	(1)	Iowa City, Iowa	9 am-1:30 pm; 2-10 pm.

## 890 kcs. (336.9 m.)

<ARK	a	500	N(1)	Little Rock, Ark.	
KFNF	a	500	2X(1)	Shenandoah, Iowa	6:30-10:30 am; 11:30 am-5 pm; 6-10:30 pm.
KFPY	a	1000	C(5)	Spokane, Wash.	
KUSD	a	500	2	Vermillion, S. Dak.	
WBAA	a	500	(1)	W. Lafayette, Ind.	noon-6 pm.
WGST	a	1000	C(5)	Atlanta, Ga.	
WTAR	a	1000	R(5)	Providence, R. I.	
WMMN	a	1000	C(5)	Fairmont, W. Va.	6:30 am-1:00 am.
XEW	a	100000	...	Mexico City, D. F.	

## 900 kcs. (333.1 m.)

KGBU	a	500	X	Ketchikan, Alaska	
KHJ	a	1000	M(5)	Los Angeles, Calif.	9 am-4 am.
KSEI	a	250	N(1)	Pocatello, Idaho	
WBEN	a	1000	KR(5)	Buffalo, N. Y.	
WELI	a	500	D	New Haven, Conn.	
WFMD	a	500	D	Frederick, Md.	(6:30 am-LS.
WIXA	a	1000	N(5)	Jacksonville, Fla.	6:45 am-1 am.
WKY	a	1000	N(5)	Oklahoma City, Okla.	
WLBL	a	5000	D	Stevens Point, Wis.	9 am-5:15 pm.
WTAD	a	1000	D	Quincy, Ill	

## 910 kcs. (329.6 m.)

CBF	a	50000	FN	Montreal, P. Q.	
CIAT	a	1000	F	Trail, B. C.	
CKY	a	15000	F	Winnipeg, Man.	8:30 am-1:30 am.
CMKD	a	1000	....	Havana, Cuba	
CMOA	z	200	..	Havana, Cuba	
TIRS	z	250	915	San Jose, Costa Rica	
XENT	a	150000	A	Nuevo Laredo, Tams.	7 pm-8:15 am.

## 920 kcs. (325.9.)

CMHT	z	200	....	Trinidad, Cuba.	
KFEL	a	500	Ma	Denver, Colo.	
KOMO	a	1000	R(5)	Seattle, Wash.	10 am-3 am.
KPRC	a	1000	R(5)	Houston, Texas	7 am-1 am.
KVOD	a	500	Ba	Denver, Colo.	10:30 am-12:30 pm; 2:30-5 pm; 6:30-8 pm; 9:30 pm-2:30 am.
WAAF	a	1000	D	Chicago, Ill.	
WORL	a	500	D	Boston, Mass.	7 am-LS.
WPEN	a	1000	...	Philadelphia, Pa.	
WRAX	a	1000	Q	Philadelphia, Pa.	
WSPA	a	1000	D	Spartanburg, S. C.	6 am-LS.
WWJ	a	1000	R(5)	Detroit, Mich.	

## 930 kcs. (322.4 m.)

CFAC	a	1000	F	Calgary, Alta.	
CFCH	a	100	F	North Bay, Ont.	
CFLC	a	100	....	Prescott, Ont.	
CHNS	a	1000	F	Halifax, N. S.	7 am-11:15 pm.
CKPC	a	100	....	Brantford, Ont.	
CMJF	z	200	....	Camaguey, Cuba	
KMA	a	1000	B(5)	Shenandoah, Iowa	
KROW	a	1000	....	Oakland, Calif.	10 am-4 am.
WBRC	a	1000	R(5)	Birmingham, Ala.	7:15 am-1 am.
WDBJ	a	1000	C(5)	Roanoke, Va.	7 am-midnight.
XEBH	a	500	....	Hermosillo, Son.	

Monday Thru Friday

Eastern Standard

940 kcs. (319 m.)

CMBZ	a	200	....	Havana, Cuba	
KOIN	a	1000	C(5)	Portland, Ore.	
WAAT	a	500	D	Jersey City, N. J.	
WAVE	a	1000	N	Louisville, Ky.	7 am-2 am.
WCSH	a	1000	R(2.5)	Portland, Me.	7:15 am-midnight.
WDAY	a	1000	N(5)	Fargo, N. Dak.	
WHA	a	5000	D	Madison, Wis.	9 am-LS.
WICA	a	250	D	Ashtabula, Ohio	7 am-LS.
XEFO	a	5000	....	Mexico City, D. F.	

950 kcs. (315.6 m.)

CBV	a	1000	F	Quebec, P. Q.	Noon-midnight.
CJOC	a	100	F	Lethbridge, Alta.	8 am-1 am.
CMKL	z	200	....	Bayamo, Cuba	
KFWB	a	1000	(5)	Los Angeles, Calif.	9 am-3 am.
KMBC	a	1000	C(5)	Kansas City, Mo	
TIRH	z	1000	....	San Jose, Costa Rica	
WRC	a	1000	R(5)	Washington, D. C	
WTRY	z	1000	DP	Troy, N. Y.	

960 kcs. (312.3 m.)

CBY	a	500	F	Toronto, Ont.	Noon-midnight.
CFRN	a	100	F	Edmonton, Alta.	MWThF, 6:30 am-11 pm; Tu, 6:30 am-10 pm.
CRCY	a	100	F	Toronto, Ont.	
XEAW	a	100000	....	Reynosa, Tams.	5-7:15 am; 7 pm-12:30 am.
XECL	z	1000	....	Mexicali, B. Cfa.	

970 kcs. (309.1 m.)

CMCK	a	5000	....	Havana, Cuba	
KJR	a	5000	B	Seattle, Wash.	10 am-3 am.
WCFL	a	5000	N	Chicago, Ill.	
WIBG	a	100	D	Glenside, Pa.	7:30 am-LS.

980 kcs. (306 m.)

KDKA	b	50000	B	Pittsburgh, Pa.	
XEAC	a	5000	....	Tijuana, B. Cfa.	8 am-1 am.
XEFE	z	250	....	Nuevo Laredo, Tams.	

990 kcs. (302.8 m.)

WBZ	a	50000	BSy	Boston, Mass.	6 am-1 am.
WBZA	a	1000	BSy	Springfield, Mass.	6 am-1 am.
XEFF	z	250	....	Nogales, Son.	
XEK	a	100	....	Mexico City, D. F.	
XES	a	250	....	Tampico, Tams.	

1000 kcs. (299.8 m.)

KFVD	a	1000	L	Los Angeles, Calif.	
VOCM	z	200	1006	St. John's Nfld.	
WHO	a	50000	KR	Des Moines, Iowa	7 am-1 am.
XEBI	a	250	....	Aguascalientes, Ags.	

1010 kcs. (296.9 m.)

CHML	a	100	F	Hamilton, Ont.	7 am-11:30 pm.
CKCD	a	100	1	Vancouver, B. C.	MT, 10:30 am-2:30 am; WF, 11 am-midnight; Th, 10:30 am-12:30 am.
CKCK	a	1000	F	Regina, Sask.	9 am-2 am.
CKCO	a	100	F	Ottawa, Ont.	
CKIC	a	50	.	Wolfville, N. S.	
CKWX	a	100	1F	Vancouver, B. C.	MT, 9:30 am-10:30 pm; WF, 9:30 am-11:30 pm; W midnight-2 am; Th, 9:30 am-10:30 pm; F midnight-1:30 am.
CMQ	a	25000	N	Havana, Cuba	
KGGF	a	1000	2M	Coffeyville, Kans.	MTWTF, 8 am-11:30 pm; TW, 12:30-3 pm; TuTh, 5-8 pm; W, 5-11:30 pm.
KQW	a	1000	M	San Jose, Calif.	9:15 am-3 am.

## Monday Thru Friday

## Eastern Standard

WHN	a	1000	(5)	New York, N. Y.	7 am-1 am.
WNAD	a	1000	2	Norman, Okla.	TWT, 11:30 am-12:30 pm; 3-5 pm; TT, 8-9 pm; W-9-10 pm.
WNOX	a	1000	C(5)	Knoxville, Tenn.	6:30 am-2 am.
XEFQ	a	50	....	Cananea, Son.	
XEU	a	250	....	Veracruz, Ver.	

## 1020 kcs. (293.9 m.)

KYW	c	10000	R	Philadelphia, Pa.	6 am-1:15 am.
WDZ	a	250	DX	Tuscola, Ill.	
XEJ	a	1000	....	Juarez, Chih.	

## 1030 kcs. (291.1 m.)

CFCN	a	10000	....	Calgary, Alta.	
CJBR	z	1000	F	Rimouski, P. Q.	
CKLW	a	5000	FM	Windsor, Ont.	
XEB	a	10000	....	Mexico City, D. F.	

## 1040 kcs. (288.3 m.)

KRLD	a	10000	CX	Dallas, Texas	
KWJJ	a	500	H	Portland, Ore.	9 am-LS; midnight-6 am.
KYOS	a	250	D	Merced, Calif.	9 am-LS.
WTIC	a	50000	R	Hartford, Conn.	6 am-1 am.

## 1050 kcs. (285.5 m.)

CBA	z	50000	P	Sackville, N. B.	
CBM	a	5000	FR	Montreal, P. Q.	
CMCP	z	200	....	Havana, Cuba	
HIT	z	50	....	Ciudad Trujillo, D. R.	
KFBI	a	5000	L	Abilene, Kans.	7 am-LS.
KNX	c	50000	C	Los Angeles, Calif.	9 am-4 am.
WEAU	a	1000	D	Eau Claire, Wis.	
WIBC	a	1000	D	Indianapolis, Ind.	7 am-LS.

## 1060 kcs. (282.8 m.)

CMHI	a	200	....	Santa Clara, Cuba	
KTHS	a	10000	HN	Hot Springs, Ark.	7 am-LS; 9 pm-1 am.
VOAC	z	40	1065	St. John's, Nfld.	
WBAL	a	10000	BHM	Baltimore, Md.	
WJAG	a	1000	DH	Norfolk, Nebr.	7:15 am-LS.
W3XJ	z	100	P	College Park, Md.	

## 1070 kcs. (280.2 m.)

CMJW	z	200	....	Camaguey, Cuba	
KJBS	a	500	L	San Francisco, Calif.	1 pm-LS.
WCAZ	a	100	D	Carthage, Ill.	8 am-5 pm.
WTAM	a	50000	R	Cleveland, Ohio	

## 1080 kcs. (277.6 m.)

CMBX	a	200	....	Havana, Cuba	
CMKM	a	200	....	Manzanillo, Cuba	
WBT	a	50000	C	Charlotte, N. C.	
WCBD	a	5000	iL	Chicago, Ill.	
WMBI	g	5000	iL	Chicago, Ill.	8-8:30 am; 11:30 am-2 pm; 4-5:30 pm.
XEBA	z	20	....	Guzman, Jal.	
XEBK	a	100	....	Nuevo Laredo, Tams.	
XEDP	a	500	....	Mexico City, D. F.	

## 1090 kcs. (275.1 m.)

CMHA	z	200	....	Sagua la Grande, Cuba	
HIN	a	740	....	Ciudad Trujillo, D. R.	
KMOX	a	50000	C	St. Louis, Mo.	
XERB	a	150000	....	Rosarito Beach, B. Cfa.	



Monday Thru Friday

Eastern Standard

1100 kcs. (272.6 m.)

CBR	a	5000	F	Vancouver, B. C.	
CMHP	z	200	....	Placetas, Cuba	
KGDM	f	1000	DM	Stockton, Calif.	9 am-LS.
KWKH	a	10000	CH	Shreveport, La.	
WBIL	a	5000	1	New York, N. Y.	
WPG	a	5000	C1	Atlantic City, N. J.	8 am-6 pm; 8 pm-midnight.
XECL	z	1000	?	Mexicali, B. Cfa.	

1110 kcs. (270.1 m.)

CMCJ	a	200	....	Havana, Cuba	
KSOO	a	5000	LN	Sioux Falls, S. Dak.	7 am-LS.
WRVA	a	50000	CM	Richmond, Va.	7 am-midnight.

1120 kcs. (267.7 m.)

CBJ	a	100	F	Chicoutimi, P. Q.	3:15-11:15 pm.
CHLP	a	100	F	Montreal, P. Q.	8 am-11 pm.
CHSJ	a	100	F	St. John, N. B.	7 am, and 8:30 am-1:15 am.
CKOC	a	500	F(1)	Hamilton, Ont.	
CKX	a	1000	F	Brandon, Man.	9 am-12:30 am.
CMGF	a	200	....	Matanzas, Cuba	
KFIO	a	100	D	Spokane, Wash.	
KFSG	a	500	a(2.5)	Los Angeles, Calif.	
KRKD	a	500	a(2.5)	Los Angeles, Calif.	
KRSC	a	250	....	Seattle, Wash.	9 am-4:30 am.
KTBC	z	1000	DP	Austin, Texas	
WCOP	a	500	D	Boston, Mass.	7 am-LS.
WDEL	a	250	R(.5)	Wilmington, Del.	
WISN	a	250	C(1)	Milwaukee, Wis.	7 am-1 am.
WJBO	a	500	B	Baton Rouge, La.	
WTAW	a	500	L	College Station, Tex.	

1130 kcs. (265.3 m.)

CMJI	a	200	....	Ciego de Avila, Cuba	
KSL	a	50000	C	Salt Lake City, Utah	
WJJD	a	20000	L	Chicago, Ill.	7 am-LS at Salt Lake.
WVOV	a	1000	D	New York, N. Y.	
XEJP	z	100	....	Mexico City, D. F.	

1140 kcs. (263 m.)

CMBC	a	200	....	Havana, Cuba	
KVOO	a	25000	N	Tulsa, Okla.	
WAPI	a	5000	C	Birmingham, Ala.	7 am-1 am.
WSPR	a	500	DM	Springfield, Mo.	7 am-6:30 pm.

1150 kcs. (260.7 m.)

CMKG	z	200	....	Santiago, Cuba	
WHAM	a	50000	B	Rochester, N. Y.	6:30 am-1 am.
XEBP	z	250	....	Durango, Dgo.	
XEC	a	100	....	Tijuana, B. Cfa.	
XEDW	z	300	....	Minatitlan, Ver.	
XEL	z	250	....	Mexico City, D. F.	

1160 kcs. (258.5 m.)

CMHJ	a	200	....	Cienfuegos, Cuba	
WOWO	a	10000	1B	Fort Wayne, Ind.	
WVVA	a	5000	1C	Wheeling, W. Va.	
XEAS	a	100	....	Saltillo Coah.	
XED	e	2500	....	Guadalajara, Jal.	noon-midnight.
XEP	a	500	....	Juarez, Chih.	

1170 kcs. (256.3 m.)

CMBS	a	200	....	Havana, Cuba	
WCAU	a	50000	C	Philadelphia, Pa.	6:30 am-1 am.
XEXX	z	1000	....	Mexico City, D. F.	

## Monday Thru Friday

## Eastern Standard

## 1180 kcs. (254.1 m.)

KEX	a	5000	2B	Portland, Ore.	9:30 am-3 am.
KOB	a	10000	2N	Albuquerque, N. Mex	9 am-1 am.
WDGY	a	1000	CM(5)	Minneapolis, Min.	7:00 am-7:30 pm.
WINS	a	1000	....	New York, N. Y.	
WMAZ	a	1000	C(5)	Macon, Ga.	

## 1190 kcs. (252 m.)

CMKX	z	200	....	Santiago, Cuba	
KTKC	f	250	DM	Visalia, Calif.	9 am-LS.
VONF	a	500	1195	St. John's Nfld.	
WATR	a	100	DXZ	Waterbury, Conn.	
WOAI	a	50000	N	San Antonio, Tex.	7:30 am-12:30 am.
WSAZ	a	1000	L	Huntington, W. Va.	6 am-7:30 pm.

## 1200 kcs. (249.9 m.)

CFGP	a	100	....	Grande Prairie, Alta.	9:45 am-5 pm; 7 pm-midnight.
CHAB	a	100	F(.25)	Moose Jaw, Sask.	9 am-1 am.
CHGB	z	100	FP	St. Anne de Pocatiere, P.Q.	
CKNX	b	100	....	Wingham, Ont.	MWTF, 10:30 am-1:30 pm; Tu, 10:30 am-2 pm; MTWTF, 5:30-10:30 pm.
CKTB	a	100	F	St. Catharines, Ont.	
CMCO	a	200	....	Havana, Cuba	
ΔADA	a	100	M	Ada, Okla.	
KBTM	a	100	D	Jonesboro, Ark.	8:30 am-6:30 pm.
KELO	a	100	N	Sioux Falls, S. Dak.	1 pm-1 am.
KFTB	a	100	(.25)	Marshalltown, Iowa	7 am-10 pm.
KFXD	a	100	(.25)	Nampa, Idaho	8 am-11 pm.
KFXJ	a	100	(.25)	Grand Junction, Colo.	
KGCI	z	100	DP	Coeur d'Alene, Idaho	
KGDE	b	100	(.25)	Fergus Falls, Minn.	
KGEK	f	100	L	Sterling, Colo.	MTWTF, 1:30-3:30 pm; TuF, 9:15-10:45 pm.
KGFI	a	100	....	Los Angeles, Calif.	
KGHI	a	100	(.25)	Little Rock, Ark.	
KGVL	z	100	DP	Greenville, Tex.	
KMLB	a	100	(.25)	Monroe, La.	
KOOS	a	100	(.25)M	Marshfield, Ore.	
KSUN	a	100	(.25)	Lowell, Ariz.	9:30 am-midnight.
KVCV	a	100	....	Redding, Calif.	
KVEC	a	100	(.25)	San Luis Obispo, Calif.	9:30 am-3 am.
KVNU	z	100	P	Logan, Utah	
KVOS	b	100	M	Bellingham, Wash.	
KWG	a	100	N	Stockton, Calif.	
KWNO	a	250	D	Winona, Minn.	
WABI	a	100	(.25)	Bangor, Maine	
WAIM	a	100	C	Anderson, S. C.	
WAYX	a	100	(.25)	Waycross, Ga.	7 am-9 pm.
WBBZ	a	100	M(.25)	Ponca City, Okla	
WBHP	a	100	....	Huntsville, Alta.	
WCAT	a	100	D	Rapid City, S. Dak.	1-3 pm.
WCAX	a	100	(.25)	Burlington, Vt.	7:30 am-9 pm.
WCLO	a	100	(.25)	Janesville, Wis.	8 am-10 pm.
WCPO	a	100	(.25)	Cincinnati, Ohio	6:30 am-12:10 am.
WDSM	z	100	P	Superior, Wis.	
WENY	z	250	DP	Elmira, N. Y.	
WEST	a	100	3(.25)	Easton, Pa.	
WFAM	a	100	4	South Bend, Ind.	
WFTC	a	100	(.25)	Kinston, N. C.	
WHBC	a	100	(.25)	Canton, Ohio	
WHBY	a	100	(.25)	Green Bay, Wis.	MTuF, 9 am-10:30 pm; Th, 9 am-10:45 pm.
WIBX	a	100	C(.25)	Utica, N. Y.	
WIL	a	100	(.25)	St. Louis, Mo.	
WJBC	a	100	5(.25)	Bloomington, Ill.	
WJBL	a	100	5	Decatur, Ill.	7-10 am; 1:30-4 pm; 8:30 pm-1 am.
WJBW	a	100	..	New Orleans, La.	2 am-1 pm; 6-9 pm; midnight-1 am.
WJHI	z	100	(.25)	Johnson City, Tenn.	

Monday Thru Friday

Eastern Standard

WJNO	a	100	C(.25)	W. Palm Beach, Fla.	7 am-midnight.
WJRD	a	250	D	Tuscaloosa, Ala.	
WKBO	a	100	3(.25)	Harrisburg, Pa.	7 am-noon; 3-6 pm; 8-11 pm.
WLVA	a	100	(.25)	Lynchburg, Va.	
WMFR	a	100	D	High Point, N. C.	6:30 am-10 pm.
WMPC	a	100	(.25)	Lapeer, Mich.	
WOLS	a	100	D	Florence, S. C.	7 am-LS.
WRBL	a	100	(.25)	Columbus, Ga.	8 am-midnight.
WSAL	z	250	D	Salisbury, Md.	
WTHT	a	100	M	Hartford, Conn.	
WTOL	a	100	D	Toledo, Ohio	
WWAB	a	100	4	Hammond, Ind.	

1210 kcs. (247.8 m.)



CHLT	z	100	....	Sherbrooke, P. Q.	
CJCS	a	50	....	Stratford, Ont.	
CJCU	z	50	....	Aklavik, N. W. T.	
CKBI	a	100	F	Prince Albert, Sask.	
CKCH	a	100	F	Hull, P. Q.	
CKMC	a	50	....	Cobalt, Ont.	
CMHK	z	200	....	Cruces, Cuba	
KALB	a	100	(.25)	Alexandria, La.	
KANS	a	100	N	Wichita, Kans.	
KASA	b	100	M	Elk City, Okla.	7:30 am-7:45 pm.
KDLR	a	100	(.25)	Devils Lake, N. Dak.	
KDON	a	100	M	Monterey, Calif.	
KFJI	a	100	....	Klamath Falls, Ore.	
KFOR	a	100	CM(.25)	Lincoln, Nebr.	
KFPW	a	100	....	Fort Smith, Ark.	7:30 am-11 pm.
KFVS	a	100	5(.25)	Cape Girardeau, Mo.	
KFXM	a	100	2M	San Bernardino, Calif.	MTTF, 9 am-3 am; W, 9 am-10 pm; 12:30 am-3 am.
KGLO	a	100	C(.25)	Mason City, Iowa	7 am-1 am.
KGY	a	100	M	Olympia, Wash.	MTWF, 10 am-2 am; Th, 10 am-10:30 pm.
KHBG	a	100	D	Okmulgee, Okla.	
KIUL	a	100	....	Garden City, Kans.	8 am-9 pm.
KLAH	a	100	(.25)	Carlsbad, N. Mex.	8:30 am-11 pm.
KOCA	a	100	(.25)	Kilgore, Texas	
KPFA	a	100	N(.25)	Helena, Mont.	10:15 am-midnight.
KPPC	a	100	2	Pasadena, Calif.	
KROY	a	100	CD	Sacramento, Calif.	9:30 am-8 pm.
KVSO	a	100	M(.25)	Ardmore, Okla.	8 am-midnight.
KWJB	a	100	(.25)	Globe, Ariz.	10 am-midnight.
KWTN	z	100	A	Watertown, S. Dak.	
WALR	a	100	....	Zanesville, Ohio	7 am-midnight.
WBAX	a	100	M	Wilkes-Barre, Pa.	
WBBL	a	100	S	Richmond, Va.	
WBLY	a	100	D	Lima, Ohio	
WBRB	a	100	3	Red Bank, N. J.	MThF, 9-11 am; M, 7-9 pm; Tu, 4-7 pm; W, 5-8 pm; Th, 5-7 pm; F, 1 pm-midnight.
WCOL	a	100	N	Columbus, Ohio	7 am-1 am.
WCOU	a	100	M	Lewiston, Maine	6 am-midnight.
WCOV	z	100	DP	Montgomery, Ala.	
WCRW	a	100	4	Chicago, Ill.	noon-3 pm; 6-8 pm.
WEBQ	a	100	5(.25)	Harrisburg, Ill.	MTWTF, 7-10 am; 1-5 pm; MWF, 9:30 pm-1 am; TuTh, 8:30-10 pm.
WEDC	a	100	4	Chicago, Ill.	10-11 am; 5-6 pm; 10 pm-midnight.
WFAS	a	100	3	White Plains, N. Y.	
WFOY	a	100	(.25)	St. Augustine, Fla.	7:30 am-10 pm.
WGBB	a	100	3	Freeport, N. Y.	
WGCM	a	100	(.25)	Gulfport, Miss.	
WGNV	a	100	3	Newburgh, N. Y.	
WGRM	a	100	....	Grenada, Miss.	
WHAI	a	250	DM	Greenfield, Mass.	7 am-LS.
WHBF	a	100	(.25)	Rock Island, Ill.	
WHBU	a	100	(.25)	Anderson, Ind.	
WIBU	a	100	(.25)	Poynette, Wis.	
WJBY	a	100	(.25)	Gadsden, Ala.	8 am-11 pm.
WJEJ	a	100	....	Hagerstown, Md.	MWF, 7 am-9:30 pm; TuTh, 7 am-11 pm.

## Monday Thru Friday

## Eastern Standard

WJIM	z	100	B(.25)	Lansing, Mich.	
WJLS	z	100	(.25)P	Beckley, W. Va.	
WJMC	z	250	DP	Rice Lake, Wis.	
WJTN	a	100	B(.25)	Jamestown, N. Y.	
WJW	a	100	(.25)	Akron, Ohio	8 am-10:30 pm.
WKOK	a	100	L	Sunbury, Pa.	MWF, non-midnight; TuTh, noon-6 pm.
WMFG	a	100	(.25)	Hibbing, Minn.	
WOCB	z	100	(.25)P	Barnstable, Mass.	
WOMT	a	100	....	Manitowoc, Wis.	
WPAX	a	100	(.25)	Thomasville, Ga.	6:30 am-7:30 pm.
WPV	z	100	(.25)P	Petersburg, Va.	
WRAL	z	100	(.25)P	Raleigh, N. C.	
WSAY	z	100	(.25)	Rochester, N. Y.	
WSBC	a	100	4(.25)	Chicago, Ill.	
WSIX	a	100	(.25)	Nashville, Tenn.	
WSNJ	a	100	D	Bridgeton, N. J.	7 am-LS.
WSOC	a	100	N(.25)	Charlotte, N. C.	6:30 am-midnight.
WTAX	a	100	....	Springfield, Ill.	
WTMA	z	100	(.25)P	Charleston, S. C.	
XEAT	a	250	....	Parra. Chib.	
XEE	a	50	....	Durango, Dgo.	
XEFV	a	50	....	Juarez, Chih.	
XETH	a	100	....	Puebla, Pue.	

## 1220 kcs. (245.8 m.)

KFKU	a	1000	a(5)	Lawrence, Kans.	
KTMS	z	500	B	Santa Barbara, Calif.	
KTW	a	1000	2S	Seattle, Wash.	
KWSC	a	1000	2(5)	Pullman, Wash.	MTWTF, 9:45-11 am;MTWF, 2 pm-1 am; Th, 2-10:30 pm.
WCAD	a	500	D	Canton, N. Y.	12:30-1:30 pm; 3-4 pm.
WCAE	a	1000	MR(5)	Pittsburgh, Pa.	7 am-1:30 am;
WDAE	a	1000	C(5)	Tampa, Fla.	7 am-midnight.
WREN	a	1000	Ba(5)	Lawrence, Kans.	
XEBL	a	50	....	Mazatlan, Sin.	
XEDA	z	200	....	Gral. Anaya, D. F.	
XETF	a	12	....	Veracruz, Ver.	

## 1230 kcs. (243.8 m.)

CMCB	a	200	....	Havana, Cuba	
KGBX	a	500	N	Springfield, Mo.	
KGGM	a	100	....	Albuquerque, N. Mex.	9 am-1 am.
KYA	a	1000	(5)	San Francisco, Calif.	9:30 am-3 am.
WPBM	a	1000	C(5)	Indianapolis, Ind.	
WNAC	a	1000	R(5)	Boston, Mass.	
WOL	a	1000	M	Washington, D.C.	6 am-2 am.
XECA	z	250	....	Tampico, Tamps	
XEG	z	250	....	Monterrey, N. L.	

## 1240 kcs. (241.8 m.)

CJCB	a	1000	F	Sydney, N. S.	7 am-1 am.
CMAB	z	200	....	Pinar del Rio, Cuba	
CMHB	z	200	....	Sancti Spiritus, Cuba	
KGCU	a	250	....	Mandan, N. Dak.	11 am-midnight.
KTAT	a	1000	M	Fort Worth, Tex.	7:30 am-midnight.
KTFI	a	1000	N	Twin Falls, Idaho	8 am-1 am.
WKAQ	a	1000	....	San Juan, P. R.	
WXYZ	a	1000	B	Detroit, Mich.	
XEBU	z	50	....	Chihuahua, Chih.	
XEKL	b	500	A	Leon, Gto.	
XEME	z	50	....	Merida, Yuc.	

## 1250 kcs. (239.9 m.)

CMKC	a	200	....	Santiago, Cuba	
CMKC	a	200	....	Tegucigalpa, Hond.	

Monday Thru Friday

Eastern Standard

KFOX	a	1000	....	Long Branch, Calif.	
KIT	a	250	MX(.5)	Yakima, Wash.	9:30 am-3 am.
KXOK	z	1000	....	St. Louis, Mo.	
WAIK	a	250	D	Winston-Salem, N. C.	6 am-LS.
WDSU	a	1000	B	New Orleans, La.	
WHBI	a	1000	(2.5)	Newark, N. J.	
WKST	z	250	D	New Castle, Pa.	7 am-LS.
WMRO	z	250	D	Aurora, Ill.	
WNEW	a	1000	(2.5)	New York, N. Y.	
WTCN	a	1000	B(5)	Minneapolis, Minn.	7 am-1 am.
XEAI	z	500	....	Mexico City, D. F.	

1260 kcs. (238 m.)



CMJO	a	200	....	Ciego de Avila, Cuba	
CMX	e	200	....	Havana, Cuba	8 am-1 am.
KGVO	a	1000	C(5)	Missoula, Mont.	9 am-1 am.
KHSL	a	250	....	Chico, Calif	
KOIL	a	1000	BM(5)	Omaha, Nebr.	
KPAC	a	500	D	Port Arthur, Tex.	7 am-LS.
KRGV	a	1000	MN	Weslaco, Texas	7:30 am-midnight.
KUOA	a	5000	D	Siloam Springs, Ark.	7 am-LS.
KVOA	a	1000	....	Tucson, Ariz.	8 am-11:30 pm.
WHIO	a	1000	C(5)	Dayton, Ohio	
WNBX	a	1000	CM	Springfield, Vt.	7 am-midnight.
WTOC	a	1000	C	Savannah, Ga.	6 am-midnight.

1270 kcs. (236.1 m.)



CMHD	b	200	....	Caibarien, Cuba	
KGCA	a	100	2D	Decorah, Iowa	
KOL	a	1000	M(5)	Seattle, Wash.	
KVOR	a	1000	C	Colorado Springs, C.	8:45 am-1:45 am.
KWLC	a	100	2D	Decorah, Iowa	7:30-9:30 am; 10:45-11:45 am! 12:30- 1:30 pm.
WASH	a	500	DNA	Grand Rapids, Mich.	
WFBR	a	500	R(1)	Baltimore, Md.	6:30 am-1:30 am.
WJDX	a	1000	R(5)	Jackson, Miss.	
WOOD	a	500	Na	Grand Rapids, Mich.	
XEXB	a	250	A	Jalapa, Ver.	
XEXE	z	17	....	Texcoco, Mex.	

1280 kcs. (234.2 m.)



CMKO	z	200	....	Holguin, Cuba	
KFBB	a	1000	C(5)	Great Falls, Mont.	10 am-1 am.
KLS	a	250	....	Oakland, Calif.	
WCAM	a	500	1	Camden, N. J.	Silent.
WCAP	a	500	1	Asbury Park, N. J.	10:30 am-4 pm; 8 pm-midnight.
WDOD	c	1000	C(5)	Chattanooga, Tenn.	7 am-midnight.
WIBA	a	1000	N(5)	Madison, Wis.	8 am-1 am.
WORC	a	500	C	Worcester, Mass.	8 am-midnight.
WRR	a	500	M	Dallas, Texas	8 am-1 am.
WTNJ	a	500	1	Trenton, N. J.	
XEMX	z	100	....	Mexico City, D. F.	

1290 kcs. (232.4 m.)



CMCG	a	200	....	Havana, Cuba	
CMJK	a	200	....	Camaguey, Cuba	
KDYL	a	1000	R(5)	Salt Lake City, Utah	
KLCN	a	100	D	Blytheville, Ark	
KTRH	a	1000	C(5)	Houston, Texas	7:30 am-3:30 am.
WEBC	a	1000	N(5)	Duluth, Minn.	7:30 am-1 am.
WJAS	a	1000	C(5)	Pittsburgh, Pa.	
WJHP	z	250	P	Jacksonville, Fla.	

## Monday Thru Friday

## Eastern Standard

WNBZ	a	100	D	Saranac Lake, N. Y.	8 am-LS.
WNEL	a	1000	(2.5)	San Juan, P. R.	5:30 am-11 pm.

## 1300 kcs. (230.6 m.)

KALE	a	1000	M	Portland, Ore.	9:30 am-3 am.	(6:30 am-midnight)
KFAC	a	1000	....	Los Angeles, Calif.	24 hours daily.	(24 hours daily)
KFH	a	1000	C(5)	Wichita, Kans.	7 am-1 am.	(4 am-10 pm)
WBRR	a	1000	1	Brooklyn, N. Y.	Silent.	(Silent)
WEVD	a	1000	1	New York, N. Y.		
WFBC	a	1000	N(5)	Greenville, S. C.	6:45 am-midnight.	
WHAZ	a	1000	1	Troy, N. Y.		
WHBL	a	250	....	Sheboygan, Wis.	8 am-midnight.	

## 1310 kcs. 228.9 m.)

CHCK	a	50	....	Charlottetown, P.E.I.		
CJKL	a	100	F	North Bay, Ont.		
CJLS	a	100	F	Yarmouth, N. S.		
CKCV	a	100	F	Quebec, P. Q.	7:45 am-11:45 pm.	
KAND	z	100	DM	Corsicana, Tex.		
KARM	a	100	C	Fresno, Calif.	9 am-3 am.	
KBND	z	100	(.25)	Bend, Ore.		
KCKN	a	100		Kansas City, Kans.	7 am-1 am.	
KCRJ	a	100	(.25)	Jerome, Ariz.		
KFPL	f	100	(.25)	Dublin, Texas		
KFYO	a	100	M(.25)	Lubbock, Texas	7 am-midnight.	
KGEZ	a	100	....	Kalispell, Mont.		
KGFV	a	100	(.25)	Kearney, Nebr.	7 am-11:30 pm.	
KHUB	a	250	D	Watsonville, Calif.	9 am-LS.	
KOCY	a	100	D	Tulsa, Okla.		
KOME	z	250	D	Tulsa, Okla.		
KPDN	a	100	D	Pampa, Texas		
KRBA	a	100	D	Lufkin, Texas	7 am-6:15 pm.	
KRMD	a	100	(.25)	Shreveport, La.	7:30 am-1 am.	
KROC	a	100	(.25)	Rochester, Minn.		
KROA	a	100		Santa Fe, N. Mex.	9 am-4 pm; 6:30-11:30 pm.	
KRRV	a	250	DM	Sherman, Texas		
KSRO	a	100	(.25)	Santa Rosa, Calif.	10 am-2 am.	
KSUB	a	100	....	Cedar City, Utah		
KTSM	a	100	N(.25)	El Paso, Texas	8:30 am-2 am.	
KVOL	a	100	(.25)	Lafayette, La.	8 am-2 pm; 5-11 pm.	
KVOX	a	100	(.25)	Moorhead, Minn.	7 am-10 pm.	
KWOC	a	100	D	Poplar Bluff, Mo.	7:30 am-LS.	
KWOS	a	100	(.25)	Jefferson City, Mo.	7 am-11 pm.	
KXRO	a	100	M(.25)	Aberdeen, Wash.		
TG1	d	....	....	Guatemala C., Guat.		
WAML	a	100	(.25)	Laurel, Miss.		
WBEO	a	100	(.25)	Marquette, Mich.		
WBOW	a	100	N(.25)	Terre Haute, Ind.		
WBRE	a	100	N(.25)	Wilkes-Barre, Pa.		
WBRK	z	100	C(.25)	Pittsfield, Mass.		
WCLS	a	100	L	Joliet, Ill.		
WCMJ	a	100	(.25)	Ashland, Ky.		
WDAH	a	100	S(.25)	El Paso, Tex.		
WFBR	a	100	B(.25)	Buffalo, N. Y.	7 am-midnight.	
WEMP	a	100	....	Milwaukee, Wis.		
WEXL	a	50	....	Royal Oak, Mich.	8 am-4 am.	
WFBG	a	100	3	Altoona, Pa.		
WPDF	a	100	B	Flint, Mich.	6 am-midnight.	
WGAU	a	100	(.25)	Athens, Ga.	7 am-midnight.	
WGH	a	100	(.25)	Newport News, Va.		
WGTM	a	100	D	Wilson, N. C.		
WHAT	s	100	4	Philadelphia, Pa.		
WIAC	s	100	3(.25)	Johnstown, Pa.	8:30-10:30 am; 4:30-6:30 pm; 9:30 pm-midnight.	
WLAK	z	100	N	Lakeland, Fla.		
WLBC	a	100	(.25)	Muncie, Ind.	6:30 am-12:30 am.	
WLNH	a	100	M	Laconia, N. H.	7 am-midnight.	
WMB0	a	100	....	Auburn, N. Y.		

Monday Thru Friday

Eastern Standard

WMFF	a	100	B(.25)	Plattsburgh, N. Y.	7:45 am-midnight.
WNBH	a	100	M(.25)	New Bedford, Mass.	
WRAW	a	100	....	Reading, Pa.	
WROL	a	100	N(.25)	Knoxville, Tenn.	
WSAJ	a	100	....	Grove City, Pa.	Silent.
WSAV	z	100	P	Savannah, Ga.	
WSGN	a	100	B(.25)	Birmingham, Ala.	7 am-midnight.
WSJS	a	100	C	Winston-Salem, N. C.	6:30 am-midnight.
WTAL	a	100	(.25)	Tallahassee, Fla.	
WTEL	a	100	4	Philadelphia, Pa.	
WTJS	a	100	(.25)	Jackson, Tenn.	7 am-11 pm.
WTRC	a	100	(.25)	Elkhart, Ind.	7:30 am-10:30 pm.
XEAG	z	10	....	Cordoba, Ver.	
XEBO	z	25	....	Irapuato, Gto.	
XEFW	a	300	....	Tampico, Tams	
XETB	a	500	....	Torrecon, Coah.	
XEX	a	500	....	Monterrev, N. L.	

1320 kcs. (227.1 m.)

CMBQ	z	5000		Havana, Cuba	
KGHF	a	500	B	Pueblo, Colo.	9 am-1 am.
KGMB	a	1000	CM	Honolulu, Hawaii	11:25 am-5:30 am.
KID	a	500	(1)	Idaho Falls, Idaho	
KRNT	a	1000	C(5)	Des Moines, Iowa	6:30 am-1 am.
WADC	a	1000	C(5)	Akron, Ohio	
WORK	a	1000	N	York, Pa.	8 am-midnight.
WSMB	a	1000	R(5)	New Orleans, La.	

1330 kcs. (225.4 m.)

KGB	a	1000	M	San Diego, Calif.	
KMO	a	1000	M	Tacoma, Wash.	9 am-3 am.
KRIS	a	500	NM	Corpus Christi, Tex.	7:30 am-midnight.
KSCJ	a	1000	C(5)	Sioux City, Iowa	7 am-2 am.
WDRC	g	1000	C(5)	Hartford, Conn.	7 am-1 am.
WSAI	a	1000	MN(5)	Cincinnati, Ohio	
WTAQ	a	1000	C	Green Bay, Wis.	8 am-1 am.

1340 kcs. (223.7 m.)

KDTH	z	500	ADP	Dubuque, Iowa	
KGIR	a	1000	N(5)	Butte, Mont.	
KGNO	c	250	....	Dodge City, Kans.	7:30 am-10 pm.
WCOA	a	500	C(1)	Pensacola, Fla.	
WFEA	a	500	MN(1)	Manchester, N. H.	
WFNC	z	250	DP	Fayetteville, N. C.	
WSPD	a	1000	B(5)	Toledo, Ohio	6:30 am-1 am.
XEAP	z	50	....	Obregon, Son.	
XEBS	z	200	....	Mexico City, D. F.	
XEBW	z	250	?	Chihuahua, Chih.	
XEDH	z	200	....	Villa Acuna, Coah.	
XEFC	a	100	..	Merida, Yuc.	
XEXD	z	350	A	Orizaba, Ver.	

1350 kcs. (222.1 m.)

CMCA	a	200	....	Havana, Cuba	
CMKW	z	....	....	Santiago, Cuba	
KIDO	a	1000	N(2.5)	Boise, Idaho	9 am-2 am.
KWK	a	1000	XBM(5)	St. Louis, Mo.	
WAWZ	a	500	1(1)	Zarephath, N. J.	7:45-8:45 am; 6-7:30 pm.
WBNX	a	1000	1	New York, N. Y.	
WMBG	a	500	R	Richmond, Va.	7 am-midnight.

1360 kcs. (220.4 m.)

CMJH	b	200	....	Ciego de Avila, Cuba	
KCRC	a	250	M	Enid, Okla.	

## Monday Thru Friday

## Eastern Standard

KGFR	a	1000	....	Long Beach, Calif.	9 am-3 am.
KLPM	a	500	(1)	Minot, N. Dak.	
WCSC	a	500	N(1)	Charleston, S. C.	7 am-midnight.
WFBL	a	1000	C(5)	Syracuse, N. Y.	
WGES	a	500	1(1)	Chicago, Ill.	
WQBC	a	1000	D	Vicksburg, Miss.	
WSBT	a	500	1	South Bend, Ind.	

## 1370 kcs. (218.8 m.)

CFAR	a	100	....	Flin Flon, Man.	8am-2:15 pm; 6-10 pm.
CFOS	z	100	....	Owen Sound, Ont.	
CKCW	a	100	F	Moncton, N. B.	
CKRN	z	100	P	Rouyn, P. Q.	
CMGE	a	200	....	Cardenas, Cuba	
KAST	a	100	DXZ	Astoria, Ore.	10 am-LS.
KCMO	a	100	....	Kansas City, Mo.	
KEEN	a	100	3	Seattle, Wash.	
KELD	z	100	....	El Dorado, Ark.	
KERN	a	100	N	Bakersfield, Calif.	10 am-3 am.
KFGQ	a	100	D	Boone, Iowa	7-8:30 am; 10:30-11 am; 1-2 pm.
KFJZ	a	100	M(.25)	Fort Worth, Texas	8 am-midnight.
KFRO	a	250	DM	Longview, Texas	
KGAR	a	100	C(.25)	Tucson, Ariz.	9 am-1 am.
KGFL	a	100	4	Roswell, N. Mex.	
KGKL	a	100	(.25)	San Angelo, Texas	
KICA	a	100	4	Clovis, N. Mex.	
KIUN	a	100	....	Pecos, Texas	8 am-10 pm.
KIUP	a	100	....	Durango, Colo.	
KLUF	a	100	M(.25)	Galveston, Tex.	8 am-1 am.
KMAC	a	100	5(.25)	San Antonio, Tex.	
KOBH	a	100	(.25)	Rapid City, S. Dak.	
KOKO	a	100	....	La Junta, Colo.	8:30 am-11:30 pm.
KONO	a	100	5	San Antonio, Tex.	7-8 am; 9:30-11 am; noon-1 pm; 2:30-5 pm; 7-8 pm; 9-11 pm.
KRE	a	100	(.25)	Berkeley, Calif.	
KRKO	a	50	3M	Everett, Wash.	10 am-3 pm; 7-10 pm.
KRMC	a	100	(.25)	Jamestown, N. Dak.	
KSLM	a	100	MXZ	Salem, Ore.	10:30 am-2:30 am.
KTEM	a	250	DM	Temple, Texas	
KTOK	a	100	MN	Oklahoma City, Okla.	7 am-1 am.
KTSW	z	100	DP	Emporia, Kans.	
KUJ	a	100	....	Walla Walla, Wash.	9:30 am-1 am.
KVGB	z	100	....	Great Bend, Kans.	
KVRS	z	100	(.25)	Rock Springs, Wyo.	
KWYO	a	100	(.25)	Sheridan, Wyo.	
WABY	a	100	N(.25)	Albany, N. Y.	7 am-1 am.
WAGF	a	250	D	Dothan, Ala.	9 am-LS.
WATL	a	100	(.25)	Atlanta, Ga.	7 am-2 am.
WBLK	a	100	....	Clarksburg, W. Va.	6 am-11:30 pm.
WBNY	a	100	2(.25)	Buffalo, N. Y.	7-8:30 am; 10 am-2 am.
WBTM	a	100	(.25)	Danville, Va.	
WBTH	z	100	DP	Williamson, W. Va.	
WCBM	a	100	(.25)	Baltimore, Md.	
WCOS	z	100	P	Columbia, S. C.	
WDAS	a	100	(.25)	Philadelphia, Pa.	7:30 am-midnight.
WDWS	a	100	(.25)	Champaign, Ill.	7 am-midnight.
WEOA	a	100	C(.25)	Evansville, Ind.	8 am-1 am.
WFOR	a	100	....	Hattiesburg, Miss.	8 am-9:30 pm.
WGL	a	100	N(.25)	Fort Wayne, Ind.	
WGRC	a	250	D	New Albany, Ind.	7 am-LS.
WHBQ	a	100	....	Memphis, Tenn.	
WHDF	a	100	(.25)	Calumet, Mich.	
WHLB	a	100	C(.25)	Virginia, Minn.	
WHLS	a	250	D	Port Huron, Mich.	6 am-7:30 pm.
WIBM	a	100	(.25)B	Jackson, Mich.	
WILH	a	100	Sy	Lawrence, Mass.	
WLLH	a	100	MSy(.25)	Lowell, Mass.	7:30 am-midnight.



Monday Thru Friday

Eastern Standard

WMBR	a	100	C(.25)	Jacksonville, Fla.	7 am-midnight.
WMFD	a	100	D	Wilmington, N. C.	7:30 am-7 pm.
WMFO	a	100	D	Decatur, Ala.	7 am-LS.
WMIN	a	100	(.25)	St. Paul, Minn.	7 am-3 am.
WOC	a	100	C(.25)	Davenport, Iowa	
WPAY	a	100	....	Portsmouth, Ohio	7 am-8 pm.
WPRA	a	100	(.25)	Mayaguez, P. R.	
WRAK	a	100	(.25)	Williamsport, Pa.	7:30 am-9 pm.
WRDO	a	100	MN	Augusta, Maine	8 am-midnight.
WRJN	a	100	(.25)	Racine, Wis.	
WSAU	a	100	(.25)	Wausau, Wis.	7:30 am-1 am.
WSVS	a	50	2D	Buffalo, N. Y.	8:30 am-10 pm.
XECZ	z	100	....	San Luis Potosi, S.L.P.	
XEI	a	125	....	Morelia, Mich.	
XELZ	z	100	....	Mexico City, D. F.	

1380 kcs. (217.3 m.)



CMCW	b	200	....	Havana, Cuba	
KOH	a	500	C	Reno, Nev.	
KQV	c	500	C(1)	Pittsburgh, Pa.	7 am-12:30 am.
WALA	a	500	C(1)	Mobile, Ala.	8 am-midnight
WKBB	a	1000	C	La Crosse, Wis.	7 am-midnight.
WNBC	a	250	R(1)	New Britain, Conn.	7 am-midnight.
WSMK	a	250	C(.5)	Dayton, Ohio	6 am-7:30 pm; 10 pm-1 am.
XEM	z	500	....	Chihuahua, Chih.	

1390 kcs. (215.7 m.)



CJGX	a	100	F	Yorkton, Sask.	8:30 am-1:45 am.
CMJC	z	150	....	Camaguey, Cuba	
KABR	a	500	(1)	Aberdeen, S. Dak.	8 am-11 pm.
KLRA	a	1000	C(5)	Little Rock, Ark.	
KOY	g	1000	C	Phoenix, Ariz.	8:30 am-2 am.
KRLC	a	250	....	Lewiston, Idaho	9:30 am-12:30 am.
WHK	a	1000	BM(.25)	Cleveland, Ohio	7 am-2 am.
WQDM	f	1000	D	St. Albans, Vt.	6 am-LS.

1400 kcs. (214.2 m.)

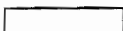

CMKR	z	200	....	Santiago, Cuba	
KHBC	a	250	CM	Hilo, Hawaii	Noon-4 am.
KLO	a	500	BX	Ogden, Utah	9:30 aam-1:30 am.
KTUL	a	1000	C(5)	Tulsa, Okla.	7:30 am-1:30 am.
TGX	d	....	....	Guatemala City, Guat.	
WARD	a	500	2	Brooklyn, N. Y.	
WBBC	a	500	2	Brooklyn, N. Y.	7-11 am; 7:30-9 pm.
WEGE	z	500	2(1)	Brooklyn, N. Y.	
WHDL	a	250	....	Olean, N. Y.	
WIRE	a	1000	MR(5)	Indianapolis, Ind.	
WLTH	a	500	2	New York, N. Y.	11 am-1:30 pm; 6-7:30 pm.
WVFW	a	500	2	Brooklyn, N. Y.	1:30-3:45 pm; 9-10:30 pm.

1410 kcs. (212.6 m.)



CKFC	a	50	5	Vancouver, B. C.	
CKMO	a	100	5	Vancouver, B. C.	
CMCQ	a	200	....	Havana, Cuba	
KFJM	a	500	(1)	Grand Forks, N. Dak	8 am-10 pm. (5 am-7 pm)
KGNC	a	1000	MN(2.5)	Amarillo, Texas	
KMED	b	250	N	Medford, Ore.	
WAAB	a	500	M(1)	Boston, Mass.	
WBGM	a	500	(1)	Bay City, Mich.	
WHIS	a	500	(1)	Bluefield, W. Va.	5 am-10 pm. (3 am-7 pm)
WROK	a	500	(1)	Rockford, Ill.	7:30 am-11 pm. (4:30 am-8 pm)
WSFA	a	500	C(1)	Montgomery, Ala.	

## Monday Thru Friday

## Eastern Standard

## 1420 kcs. (211.1 m.)

CHLN	z	100	....	Three Rivers, P. Q.		
CKCA	a	100	....	Kenora, Ont.		
CKGB	a	100	F	North Bay, Ont.	7:45 am-midnight.	
CMJP	a	200	....	Moron, Cuba		
KABC	a	100	M(.25)	San Antonio, Tex.	7:30 am-12:30 am.	
KATE	a	100	(.25)	Albert Lea, Minn.		
KBPS	a	100	4	Portland, Ore.	2-3:30 pm; 6-8 pm.	
KCMC	a	100	M(.25)	Texarkana, Tex.	8 am-midnight.	
KDNT	a	100	D	Denton, Texas	8 am-LS.	
KEUB	a	100	....	Price, Utah	10 am-10 pm.	
KFAM	a	100	(.25)	St. Cloud, Minn.	8 am-10 pm.	
KFIZ	a	100	....	Fond du Lac, Wis.		
KGFF	a	100	M(.25)	Shawnee, Okla.	8 am-1 am.	
KGIW	a	100	1	Alamosa, Colo.	9:30 am-9:30 pm.	
KGLU	z	100	(.25)	Safford, Ariz.		
KIDW	a	100	1	Lamar, Colo.		
KLBM	z	100	(.25)	La Grande, Ore.		
KNET	a	100	D	Palestine, Texas		
KORE	a	100	M	Eugene, Ore.		
KRBC	a	100	M(.25)	Abilene, Tex.		
KRBM	z	100	P(.25)	Bozeman, Mont.		
KRIC	z	100	M(.25)	Beaumont, Texas		
KRLH	a	100	D	Midland, Texas		
KSAN	a	100	....	San Francisco, Calif.	24 hrs. daily.	
KTRI	f	100	(.25)	Sioux City, Iowa	7 am-midnight.	
KUMA	a	100	D	Yuma, Ariz.		
KVAK	z	100	DP	Atchison, Kans.		
KWAL	z	100	(.25)P	Wallace, Idaho		
KWBG	a	100	....	Hutchinson, Kans.	8 am-10 pm.	
KXL	c	100	(.25)	Portland, Ore.	9 am-3 am.	
WACO	c	100	CM(.25)	Waco, Texas	9 am-1 am.	
WAGM	a	100	....	Presque Isle, Me.		
WAPQ	a	100	(.25)N	Chattanooga, Tenn.	7 am-midnight.	
WAZL	a	100	2	Hazleton, Pa.		
WBNO	a	100	(.25)	New Orleans, La.		
WBNS	a	100	(.25)	Springfield, Ill.	7 am-1 am.	
WCHV	a	100	(.25)	Charlottesville, Va.	7 am-10:05 pm.	
WEED	a	100	(.25)	Rocky Mount, N. C.	7 am-8 pm.	
WELL	a	100	B	Battle Creek, Mich.	7 am-midnight.	
WFMJ	z	100	DP	Youngstown, Ohio		
WGNC	z	100	(.25)P	Gastonia, N. C.		
WGPC	a	100	....	Albany, Ga.		
WHFC	a	100	(.25)	Cicero, Ill.	8 am-2 am.	
WHMA	z	100	D	Anniston, Ala.		
WILM	a	100	2	Wilmington, Del.		
WJMS	a	100	....	Ironwood, Mich.	8 am-8:30 pm.	(5 am-5:30 pm)
WLAP	a	100	(.25)	Lexington, Ky.	8 am-11 pm.	(5 am-8 pm)
WLEU	a	100	B(.25)	Erie, Pa.		
WMAS	a	100	C(.25)	Springfield, Mass.		
WMBB	a	100	(.25)	Detroit, Mich.	7 am-midnight.	(4 am-9 pm)
WMBH	a	100	(.25)	Joplin, Mo.	7 am-midnight.	(4 am-9 pm)
WMBS	a	100	(.25)	Uniontown, Pa.	7 am-8 pm.	(4 am-5 pm)
WMFJ	a	100	....	Daytona Beach, Fla.	8 am-11 pm.	,5 am-8 pm)
WMSD	a	100	....	Muscle Shoals City, Ala.		
WPAD	a	100	(.25)	Paducah, Ky.		
WPAR	a	100	C	Parkersburg, W. Va.		
WPRP	z	100	(.25)	Ponce, P. R.		
WSLI	a	100	(.25)	Jackson, Miss.	8 am-11 pm.	

## 1430 kcs. (209.7 m.)

CMKZ	z	200	....	Palma Soriano, Cuba		
KECA	a	1000	B(5)	Los Angeles, Calif.		
KGNF	a	1000	D	North Platte, Nebr.	8 am-LS.	
KINY	a	250	....	Juneau, Alaska		
KSO	a	1000	BM(5)	Des Moines, Iowa	7:30 am-2 am.	
WBNS	a	1000	C(5)	Columbus, Ohio		

Monday Thru Friday

Eastern Standard

WHEC	a	500	C(1)	Rochester, N. Y.	
WHP	a	500	C(1)	Harrisburg, Pa.	7:30 am-1 am.
WMPS	a	500	B(1)	Memphis, Tenn.	8 am-12:30 am.
WOKO	a	500	C(1)	Albany, N. Y.	7 am-1 am.
XERH	z	500	?	Mexico City, D. F.	

1440 kcs. (208.2 m.)

CMBY	z	200	....	Havana, Cuba	
HP50	z	....	....	Colon, Panama	
KDFN	a	500	....	Casper, Wyo.	
KELA	a	500	M	Centralia, Wash.	9:45 am-3 am.
KXYZ	a	1000	BM	Houston, Texas	
WBIG	a	1000	C	Greensboro, N. C.	6:30 am-midnight.
WCBA	a	500	a	Allentown, Pa.	
WMBD	a	1000	C(5)	Peoria, Ill.	7 am-2 am.
WSAN	a	500	Na	Allentown, Pa.	
XEFI	a	250	....	Chihuahua, Chih.	

1450 kcs. (206.8 m.)

CFCT	a	500	....	Victoria, B. C.	11 am-4:30 pm; 7:30 pm-5 am.
CHGS	f	50	F	Summerside, P. E. I.	6:30-8:30 am; 9:30 am-1:30 pm; 3-8 pm.

CMHM	z	200	....	Cienfuegos, Cuba	
KGCX	a	1000	....	Wolf Point, Mont.	
KIEM	a	500	M(1)	Eureka, Calif.	
KTBS	a	1000	N	Shreveport, La.	
TGO	d	200	....	Quezaltenango, Guat.	
WAGA	a	500	B(1)	Atlanta, Ga.	7:15 am-2 am.
WGAR	a	1000	C(5)	Cleveland, Ohio	
WHOM	a	250	....	Jersey City, N. J.	
WSAR	f	1000	M	Fall River, Mass.	7:30 am-midnight.
XEF	a	100	....	Juarez, Chih.	

1460 kcs. (205.4 m.)

CMKF	z	250	....	Holguin, Cuba	
KSTP	a	10000	R(25) X	St. Paul, Minn.	7 am-2 am.
WJSV	a	10000	CX	Washington, D. C.	7 am-1 am.

1470 kcs. (204 m.)

CMCX	z	200	....	Havana, Cuba	
KGA	a	5000	BM	Spokane, Wash.	
WLAC	a	5000	C	Nashville, Tenn.	

1480 kcs. (202.6 m.)

CMHX	a	200	....	Cienfuegos, Cuba	
KOMA	a	5000	C	Oklahoma City, Okla.	7:30 am-1 am.
WHIP	z	5000	D	Hammond, Ind.	6 am-LS.
WKBW	a	5000	C	Buffalo, N. Y.	7 am-1 am.

1490 kcs. (201.2 m.)

CMKQ	z	200	....	Santiago, Cuba	
KFBK	a	10000	N	Sacramento, Calif.	10 am-3 am.
WCKY	a	10000	NX	Covington, Ky.	6:30 am-1 am.
XECH	z	250	?	Toluca, Mex.	
XEDR	z	100	....	Guaymas, Son.	

1500 kcs. (199.9 m.)

CJIC	a	100	F	Sault Ste. Marie, Ont.	10 am-midnight.
CMOX	a	200	....	Havana, Cuba	
KAWM	a	100	....	Gallup, N. Mex.	10 am-10 pm.

Monday Thru Friday				Eastern Standard
KBIX	a	100	M Muskogee, Okla.	8 am-1 am. (5 am-10 pm)
KBKR	z	100	(.25)P Baker, Ore.	
KBST	a	100	M Big Spring, Tex.	
KDAL	a	100	C Duluth, Minn.	7:30 am-midnight.
KDB	a	100	M(.25) Santa Barbara, Calif.	10 am-3 am.
KFDA	z	100	P Amarillo, Texas	
KGFI	a	100	(.25) Brownsville, Tex.	8 am-midnight.
KGKB	a	100	M(.25) Tyler, Texas	8 am-1 am.
KGKY	a	100	(.25) Scottsbluff, Nebr.	
KNEL	a	250	D Brady, Texas	
KNOW	a	100	CM Austin, Texas	
KOTN	a	100	D Pine Bluff, Ark.	
KOVC	a	100	(.25) Valley City, N. Dak.	
KPAB	a	100	(.25) Laredo, Tex.	7:30 am-11 am.
KPLC	a	100	(.25) Lake Charles, La.	
KPLT	a	250	DM Paris, Texas	
KPQ	a	100	M(.25) Wenatchee, Wash.	
KRNR	a	100	M(.25) Roseburg, Ore.	
KROD	z	100	AP El Paso, Texas	
KSAL	a	100	(.25) Salina, Kans.	
KSAM	z	100	D Huntsville, Texas	
KTOH	z	100	(.25)P Lihue, Hawaii	
KUTA	a	100	N Salt Lake City, Utah	9 am-2 am.
KVNU	z	100	P Logan, Utah	
KVOE	a	100	M Santa Ana, Calif.	10 am-3 am.
KVWC	z	100	P Vernon, Texas	
KWEW	z	100	D Hobbs, N. Mex.	
KXO	a	100	M El Centro, Calif.	
KYCA	z	100	A(.25)P Prescott, Ariz.	
KYSM	z	100	(.25) Mankato, Minn.	7 am-3 am.
WCNW	a	100	1(.25) Brooklyn, N. Y.	3-9 pm.
WDAN	a	250	D Danville, Ill.	7:30 am-LS.
WDNC	a	100	C Durham, N. C.	7 am-11 pm.
WGAL	a	100	(.25) Lancaster, Pa.	
WGIL	z	250	DP Galesburg, Ill.	
WGKV	z	100	P Charleston, W. Pa.	
WHBB	a	100	.... Selma, Ala.	8 am-10 pm.
WJBK	a	100	(.25) Detroit, Mich.	
WKAT	a	100	(.25) Miami Beach, Fla.	
WKBB	a	100	YC(.25) E. Dubuque, Ill.	7:30 am-noon.
WKBV	a	100	(.25) Richmond, Ind.	9:30 am-9:30 pm.
WKCB	a	100	(.25) Muskegon, Mich.	7 am-10 pm.
WKEU	a	100	D Griffin, Ga.	
WMEX	a	100	(.25) Boston, Mass.	
WNBF	a	100	C(.25) Binghamton, N. Y.	
WNLC	a	100	DM New London, Conn.	7:30 am-LS.
WOMI	a	100	(.25) Owensboro, Ky.	8 am-midnight.
WOPI	a	100	.... Bristol, Tenn.	6 am-11 pm.
WRDW	a	100	C(.25) Augusta, Ga.	
WRGA	a	100	(.25) Rome, Ga.	7:30 am-11 pm.
WRKL	z	100	DP Rock Hill, S. C.	7 am-1 am.
WRTO	a	100	B Richmond, Va.	
WSTP	z	100	(.25) Salisbury, N. C.	
WSYB	a	100	.... Rutland, Vt.	8:30-9 pm.
WTMV	a	100	(.25) E. St. Louis, Ill.	
WWRL	a	100	1(.25) Woodside, N. Y.	
WWSW	a	100	(.25) Pittsburgh, Pa.	

### 1510 kcs. (198.6 m.)

CFRC	a	100	F Kingston, Ont.	8 am-11:15 pm.
CKCR	a	100	Waterloo, Ont.	

### 1520 kcs. (197.3 m.)

TGW	d	1000	.... Guatemala City, Guat.	
-----	---	------	----------------------------	--

### 1530 kcs. (196 m.)

CMC	z	200	.... Havana, Cuba	
KITE	a	1000	.... Kansas City, Mo.	6 am-3 am.
WBRV	a	1000	M Waterbury, Conn.	8 am-midnight.

Monday Thru Friday

Eastern Standard

1550 kcs. (193.4 m.)

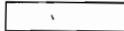

KPMC a 1000 M

Bakersfield, Calif.

9:45 am-3 am.  
7:30-11 am; 4 pm-  
midnight.

WQXR a 1000 ....

New York, N. Y.

1560 kcs. (192.2 m.)



CMBF z 5000 ....

Havana, Cuba

1580 kcs. (189.8 m.)



CM9RT z 200 ....

Guines, Cuba

1600 kcs. (187.4 m.)



CMBH z 5000 ....

Havana, Cuba

**TIME CONVERTER**

The RADEX Map of the World with Time Converting Dial is the most useful accessory any radio fan could have around. Just a twirl of the dial shows the correct time at any location in the world. No calculation is necessary; the dial does all the work. **The price is only**  
**You Can't Get Along Without It.**

**25c**

The Radex Publishing Co., 362 Cedar Lane, Teaneck, N. J.

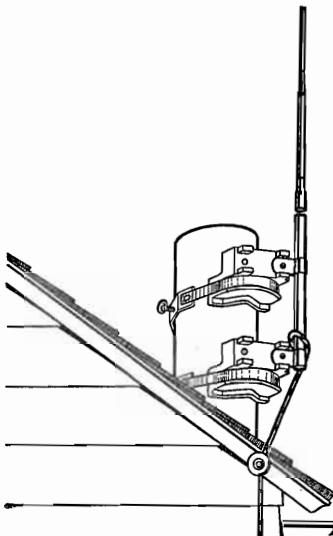

No longer need Henry risk life or limb in putting up the aerial, for there's a new aerial on the market that goes up without any poles, supports or guy wires.

Manufactured by The Ward Products Corp., Cleveland, Ohio, the new aerial mast is made of attractive, nickel-plated, super-sized bronze tubing, four sectional, 12 ft. in height. Easy to install, it mounts vertically to any suitable surface such as soil pipe (as shown) cornice, window frame, garage, etc.

The new aerial operates on the same principle as modern broadcasting stations with their vertical antenna masts, and is claimed to give better pick-up, better reception than the unsightly old "clothes-line" aerials.

Even with the best of aerials, you still need RADEX to keep abreast of radio. Get it every month on your newsstand.

### NORTH AMERICAN B. C. STATIONS BY LOCATIONS

*Frequency in kilocycles in second column. Night power in watts in third column.  
Net work affiliations in fourth column, C Columbia, R National Red, B National Blue, N National Red and Blue, P Canadian, M Mutual.*

<b>ALABAMA</b>		<b>Het Springs</b>				<b>San Diego</b>		<b>New Haven</b>	
Anniston		KTHS 1060	10000 N	KFSD 600	1000 B	WELI 900		500	
WHMA	1420 100	Jonesboro		KGB 1330	1000M	New London			
Birmingham		KBTM 1200	100	<b>San Francisco</b>		WNLC 1500		100M	
WAPI	1140 5000 C	Little Rock		KFRC 610	1000M	Waterbury			
WBRC	930 1000 R	KARK 890	500 N	KGO 790	7500 B	WATR 1190		100	
WSGN	1310 100 B	KGHI 1200	100	KJBS 1070	500	WBRY 1530		1000M	
Decatur		KLRA 1390	1000 C	KPO 680	50000 R				
WMFO	1370 100	Pine Bluff		KSAN 1420	100				
Dothan		KOTN 1500	100	KSFO 560	1000 C				
WAGF	1370 250	Siloam Springs		KYA 1230	1000				
Gadsden		KUOA 1260	5000						
WJBY	1210 100			<b>San Jose</b>					
Huntsville				KQW 1010	1000M				
WBHP	1200 100			<b>San Luis Obispo</b>					
Mobile				KVEC 1200	100				
WALA	1380 500 C	<b>CALIFORNIA</b>							
Montgomery				<b>Santa Ana</b>					
WCOV	1210 100	Bakersfield		KVOE 1500	100M				
WSFA	1410 500 C	KERN 1370	100 N	<b>Santa Barbara</b>					
Selma		KPMC 1550	1000M	KDB 1500	100M				
WHBB	1500 100	Berkeley		KTMS 1220	500 B				
Musela Shoals City		KRE 1370	100	<b>Santa Rosa</b>					
WMSD	1420 100	Beverly Hills		KSRO 1310	100				
Tuscaloosa		KMPCC 710	500	<b>Stockton</b>					
WJRD	1200 250	Chico		KGDM 1100	1000M				
		KHSL 1260	250	KWG 1200	100 N				
		El Centro		<b>Visalia</b>					
		KXO 1500	100M	KTKC 1190	250M				
		Eureka		<b>Watsonville</b>					
		KIEM 1450	500M	KHUB 1310	250				
		Fresno							
<b>ALASKA</b>		KARM 1310	100 C	<b>COLORADO</b>					
		KMJ 580	1000 N	<b>Alamosa</b>					
		Glendale		KGIW 1420	100				
		KIEV 850	250	<b>Colorado Springs</b>					
		Long Beach		KVOR 1270	1000 C				
KPQD	780 250	KFOX 1250	1000	<b>Denver</b>					
Fairbanks		KGER 1360	1000	KFEL 920	500M				
KFAR	610 1000	Los Angeles		KLZ 560	1000 C				
Juneau		KECA 1430	1000 B	KOA 830	50000 R				
KINY	1430 250	KEHE 780	1000	KPOF 880	1000				
Ketchikan		KFAC 1300	1000	KVOD 920	500 B				
KGBU	900 500	KFI 640	50000 R	<b>Durango</b>					
		KFSG 1120	500	KIUP 1370	100				
<b>ARIZONA</b>		KFVD 1000	1000	<b>Grand Junction</b>					
		KFWB 950	1000	KFXJ 1200	100				
KWJB	1210 100	KGFB 1200	100	<b>Greeley</b>					
Jerome		KHJ 900	1000M	KFA 880	500M				
KCRJ	1310 100	KMTR 570	1000	<b>La Junta</b>					
Lowell		KNX 1050	50000 C	KOKO 1370	100				
KSUN	1200 100	KRKD 1120	500	<b>Lamar</b>					
Phoenix		Merced		KIDW 1420	100				
KOY 1390	1000 C	KYOS 1040	250	<b>Pueblo</b>					
KTAR 620	1000 N	Modesto		KGHF 1320	500 B				
Prescott		KTRB 740	250	<b>Sterling</b>					
KYCA 1500	100	Monterey		KGFK 1200	100				
Safford		KDON 1210	100M	<b>CONNETICUT</b>					
KGLU 1420	100	Oakland		<b>Bridgeport</b>					
Tucson		KLS 1280	250	WICC 600	500M				
KGAR 1370	100 C	KLK 880	1000	<b>Hartford</b>					
KVOA 1260	1000	KROW 930	1000	WDRC 1330	1000 C				
Yuma		Pasadena		WTC 1040	50000 R				
KUMA 1420	100	KPPC 1210	100	WTHT 1200	100M				
		Redding		<b>New Britain</b>					
<b>ARKANSAS</b>		KVCV 1200	100	WNBC 1380	250 R				
		Sacramento							
Blytheville		KFBK 1490	10000 N						
KLCN 1290	100	KROY 1210	100 C						
El Dorado		San Bernardino							
KELD 1370	100	KFXM 1210	100M						
Fort Smith									
KFPW 1210	100								

**GEORGIA**

<b>ALBANY</b>		<b>ALBANY</b>	
WGPC 1420	100		
<b>ATHENS</b>		<b>ATHENS</b>	
WGAT 1310	100		
<b>ATLANTA</b>		<b>ATLANTA</b>	
WAGA 1450	500 B		
WATL 1370	100		
WGST 890	1000 C		
WSB 740	50000 R		
<b>AUGUSTA</b>		<b>AUGUSTA</b>	
WRDW 1500	100 C		

NORTH AMERICAN B. C. STATIONS BY LOCATIONS

<b>Columbus</b>		
WRRB	1200	100
Griffin		
WKBU	1500	100
Macon		
WMAZ	1780	1000 C
Rome		
WRGA	1500	100
Savannah		
WSAV	1310	100
WTOC	1260	1000 C
Thomasville		
WPAX	1210	100
Waycross		
WAYX	1200	100

**HAWAII**

Hilo		
KHBC	1400	250 M
Honolulu		
KGMB	1320	1000 C
KGU	750	2500 N
Lihue		
KTOH	1500	100

**IDAHO**

<b>Boise</b>		
KIDO	1350	1000 N
Coeur d'Alene		
KGCI	1200	100
Idaho Falls		
KID	1320	500
Lewiston		
KRLC	1390	250
Nampa		
KFXD	1200	100
Pocatello		
KSEI	900	250 N
TwIn Falls		
KTFI	1240	1000 N
Wallace		
KWAL	1420	100

**ILLINOIS**

<b>Aurora</b>		
WMRO	1250	250
Bloomington		
WJBC	1200	100
Carthage		
WCAZ	1070	100
Champaign		
WDWS	1370	100
Chicago		
WAAF	920	1000
WBBM	770	50000 C
WCBD	1080	5000
WCFL	970	5000 N
WCRW	1210	100
WEDC	1210	100
WENR	870	50000 B
WGES	1360	500
WGN	720	50000 M
WJJD	1130	20000
WLS	870	50000 B
WMAQ	670	50000 R
WMBI	1080	5000
WSBC	1210	100

<b>Cicero</b>		
WHFC	1420	100
Danville		
WDAN	1500	250
Decatur		
WJBL	1200	100
East Dubuque		
WKBB	1500	100 C
East St. Louis		
WTMV	1500	100
Galesburg		
WGIL	1500	250
Harrisburg		
WEBQ	1210	100
Joliet		
WCLS	1310	100
Peoria		
WMPD	1440	1000 C
Quincy		
WTAD	900	1000
Rockford		
WROK	1410	500
Rock Island		
WHBF	1210	100
Springfield		
WCBS	1420	100
WTAX	1210	100
Tuscola		
WDZ	1020	250
Urbana		
WILL	580	1000

**INDIANA**

<b>Anderson</b>		
WHBU	1210	100
Elkhart		
WTRC	1310	100
Evansville		
WEOA	1370	100 C
WGEB	630	500 N
Fort Wayne		
WGL	1370	100 N
WOWO	1160	10000 B
Gary		
WIND	560	1000
Hammond		
WHIP	1480	5000
WWAE	1200	100
Indianapolis		
WFPM	1230	1000 C
WIBC	1050	1000
WIRE	1400	1000 R
Muncie		
WLBC	1310	100
New Albany		
WGRC	1370	250
Richmond		
WKEV	1500	100
South Bend		
WFAM	1200	100
WSBT	1360	500
Terre Haute		
WBOW	1310	100 N
West Lafayette		
WBAA	890	500

**IOWA**

<b>Ames</b>		
WOI	640	5000

<b>Boone</b>		
KFGQ	1370	100
Cedar Rapids		
WMT	600	1000 B
Davenport		
WOC	1370	100 C
Decorah		
KGCA	1270	100
KWLC	1270	100
Des Moines		
KRNT	1320	1000 C
KSO	1430	1000 B
WHO	1000	50000 R
Dubuque		
KDTH	1340	500
Iowa City		
WSUI	880	500
Marshalltown		
KFJB	1200	100
Mason City		
KGLO	1210	100 C
Shenandoah		
KPNF	890	500
KMA	930	1000 B
Sioux City		
KSCJ	1330	1000 C
KTRI	1420	100

**KANSAS**

<b>Abilene</b>		
KFBI	1050	5000
Atchison		
KVAK	1420	100
Coffeyville		
KGGF	1010	1000 M
Dodge City		
KGNO	1340	250
Emporia		
KTSW	1370	100
Garden City		
KIUL	1210	100
Great Bend		
KVGB	1370	100
Hutchinson		
KWBG	1420	100
Kansas City		
KCKN	1310	100
Lawrence		
KFKU	1220	1000
WREN	1220	1000 B
Manhattan		
KSCA	580	500
Pittsburg		
KOAM	790	1000 N
Salina		
KSAL	1500	100
Topeka		
WIBW	580	1000 C
Wichita		
KANS	1210	100 R
KFH	1300	1000 C

**KENTUCKY**

<b>Ashland</b>		
WCMI	1310	100
Covington		
WCKY	1490	10000 N

<b>Lexington</b>		
WLAP	1420	100
Louisville		
WAVE	940	1000 N
WHAS	820	50000 C
Owensboro		
WOMT	1500	100
Paducah		
WPAD	1420	100

**LOUISIANA**

<b>Alexandria</b>		
KALB	1210	100
Baton Rouge		
WBFO	1120	500 B
Lafayette		
KVOL	1310	100
Lake Charles		
KPLC	1500	100
Monroe		
KMLB	1200	100
New Orleans		
WBNO	1420	100
WDSU	1250	1000 B
WJBW	1200	100
WSMB	1320	1000 R
WWL	850	50000 C
Shreveport		
KRMD	1310	100
KTBS	1450	1000 N
KWKH	1100	10000 C

**MAINE**

<b>Augusta</b>		
WRDO	1370	100 M
Bangor		
WABI	1200	100
WLBZ	620	500 N
Lewiston		
WCOU	1210	100 M
Portland		
WCSE	940	1000 R
WGAN	640	500
Presque Isle		
WAGM	1420	100

**MARYLAND**

<b>Baltimore</b>		
WBAL	760	2500 B
WBAL	1060	10000 B
WCAO	600	500 C
WCBM	1370	100
WFBR	1270	500 R
College Park		
W3XJ	1060	100
Cumberland		
WTBO	800	250
Frederick		
WFMD	900	500
Hagerstown		
WJEJ	1210	100
Salisbury		
WSAL	1200	250

**MASSACHUSETTS**

<b>Barnstable</b>		
WOCB	1210	100

## NORTH AMERICAN B. C. STATIONS BY LOCATIONS

<b>Boston</b>			<b>MINNESOTA</b>			<b>St. Joseph</b>			<b>WCAP</b>					
WAAB	1410	500M				KFEQ	680	2500	Atlantic	1280	500			
WBZ	990	50000 B	<b>Albert Lea</b>			<b>St. Louis</b>			Bridgeton	1100	5000 C			
WCOP	1120	500	KATE	1420	100	KFUO	550	500	WSNJ	1210	100			
WEEI	590	1000 C	KDLH	Duluth		KMox	1090	50000 C	Camden					
WHDH	830	1000	KDAL	1500	100 C	KSD	550	1000 R	WCAM	1280	500			
WMEX	1500	100	WEBC	1290	1000 N	KWK	1350	1000 B	Jersey City					
WNAC	1230	1000 R	Fergus Falls			KXOK	1250	1000	WAAT	940	500			
WORL	920	500	KGDE	1200	100	WEW	760	1000	WHOM	1450	250			
<b>Fall River</b>			<b>Hibbing</b>			<b>Springfield</b>			<b>Newark</b>					
WSAR	1450	1000M	WMFG	1210	100	KGBX	1230	500 N	WBBI	1250	1000			
<b>Greenfield</b>			<b>Mankato</b>			KWTO	580	5000	WOR	710	50000M			
WHAI	1210	250M	KYSM	1500	100									
<b>Lawrence</b>			<b>Minneapolis</b>			<b>MONTANA</b>								
WLAW	680	1000	WCCO	810	50000 C	<b>Billings</b>								
WLLH	1370	100M	WDGY	1180	1000 C	KGHL	780	1000 N	<b>Bozeman</b>					
<b>Lowell</b>			WLB	760	1000	KRBM	1420	100	<b>Butte</b>					
WLLH	1370	100	WTCN	1250	1000 B	KGIR	1340	1000 N	<b>Great Falls</b>					
<b>New Bedford</b>			<b>Moorhead</b>			KFB	1280	1000 C	<b>Helena</b>					
WLLH	1370	100M	KVOX	1310	100	KPFA	1210	100 N	<b>Kalispell</b>					
<b>Pittsfield</b>			<b>Northfield</b>			KGEZ	1310	100	<b>Missoula</b>					
WBRK	1310	100 C	WCAL	760	1000	KGVO	1260	1000 C	<b>Wolf Point</b>					
<b>Springfield</b>			<b>Rochester</b>			KGCV	1450	1000						
WBZA	990	1000 B	KROC	1310	100	<b>NEBRASKA</b>								
WMAS	1420	100 C	St. Cloud			<b>Clay Center</b>								
WSPR	1140	500 M	KFAM	1420	100	KMMJ	740	1000	<b>Kearney</b>					
<b>Worcester</b>			KSTP	1460	10000 R	KGFW	1310	100	<b>Lincoln</b>					
WTRC	1280	500 C	WMIN	1370	100	KFAB	770	10000 C	<b>Norfolk</b>					
WTAG	580	1000 R	Virginia			KFOR	1210	100 C	<b>North Platte</b>					
			WHLB	1370	100 C	<b>Norfolk</b>								
			Wino			<b>Omaha</b>								
			KWNO	1200	250	KOIL	1260	1000 B	<b>Omaha</b>					
			<b>MISSISSIPPI</b>			WAAW	680	500	<b>Portsmouth</b>					
			<b>Grenada</b>			WOW	590	1000 R	<b>Scottsbluff</b>					
			WGRM	1210	100	KGKY	1500	100						
			<b>Gulfport</b>			<b>NEVADA</b>								
			WGCM	1210	100	<b>Reno</b>								
			<b>Hattiesburg</b>			<b>KOH</b>								
			WFOR	1370	100									
			<b>Jackson</b>			<b>NEW HAMPSHIRE</b>								
			WJDX	1270	1000 R	<b>Laconia</b>								
			WSLI	1420	100	WLNH	1310	100M	<b>Manchester</b>					
			<b>Laurel</b>			WFEA	1340	500 N	<b>Portsmouth</b>					
			WAML	1310	100	WHEB	740	250						
			<b>Meridian</b>			<b>NEW JERSEY</b>								
			WCOO	880	1000 C	<b>Asbury Park</b>								
			<b>Vioksburg</b>											
			WQBC	1360	1000									
			<b>MISSOURI</b>											
			<b>Cape Girardeau</b>											
			KFVS	1210	100									
			<b>Columbia</b>											
			KFRU	630	500									
			<b>Jefferson City</b>											
			KWOS	1310	100									
			<b>Joplin</b>											
			WMBH	1420	100									
			<b>Kansas City</b>											
			KCMO	1370	100									
			<b>KITE</b>											
			KMBC	950	1090 C									
			<b>WDAF</b>											
			WDB	860	1000M									
			<b>Poplar Bluff</b>											
			KWOC	1310	100									
			<b>NEW MEXICO</b>											
			<b>Albuquerque</b>											
			KGGM	1230	1000									
			<b>KOB</b>											
			1180	10000 N										
			<b>Carlsbad</b>											
			KLAH	1210	100									
			<b>Clovis</b>											
			KICA	1370	100									
			<b>Gallup</b>											
			KAWM	1500	100									
			<b>Hobbs</b>											
			KWEV	1500	100									
			<b>Roswell</b>											
			KGFL	1370	100									
			<b>Santa Fe</b>											
			KRQA	1310	100									
			<b>NEW YORK</b>											
			<b>Albany</b>											
			WABY	1370	100 N									
			<b>WOKO</b>											
			1430	500 C										
			<b>Auburn</b>											
			WMBO	1310	100									
			<b>Binghamton</b>											
			WNBF	1500	100 C									
			<b>Brooklyn</b>											
			WARD	1400	500									
			<b>WBBC</b>											
			1400	500										
			<b>WBRR</b>											
			1300	1000										
			<b>WCNV</b>											
			1500	100										
			<b>WVFW</b>											
			1400	500										
			<b>Buffalo</b>											
			WBEN	900	1000 R									
			<b>WBNY</b>											
			1370	100										
			<b>WEBR</b>											
			1310	100 B										
			<b>WGR</b>											
			550	1000 C										
			<b>WKBW</b>											
			1480	5000 C										
			<b>WWSV</b>											
			1370	50										
			<b>Canton</b>											
			WCAD	1220	500									
			<b>Elmira</b>											
			WENY	1200	250									
			<b>WESG</b>											
			850	1000 C										
			<b>Freeport</b>											
			WGBB	1210	100									



NORTH AMERICAN B. C. STATIONS BY LOCATIONS

<b>Jamestown</b>	<b>Salisbury</b>	<b>KADA</b>	<b>Erle</b>
WJTN 1210 100 B	WSTP 1500 100	Ardmore 1200 100M	WLEU 1420 100 B
Newburgh	Wilmington	KVSO 1210 100M	Glenside
WGNV 1210 100	WMPD 1370 100	Eik City	WIBG 970 100
New York	Wilson	KASA 1210 100 M	Greensburg
WABC 860 50000 C	WGTM 1310 100	Enid	WHJB 620 250 C
WBIL 1100 5000	Winston-Salem	KCRC 1360 250M	Grove City
WBNX 1350 1000	WAIR 1250 250	Muskogee	WSAJ 1310 100
WBQ 860 50000	WSJS 1310 100 C	KBIX 1500 100M	Harrisburg
WEAF 660 50000 R		Norman	WHP 1430 500 C
WEVD 1300 1000	<b>NORTH DAKOTA</b>	WNAD 1010 1000	WKBO 1200 100
WHN 1010 1000		Oklahoma City	Hazelton
WINS 1180 1000	<b>Bismarck</b>	KOCY 1310 100	WAZL 1420 100
WJZ 760 50000 B	KFYR 550 1000 N	KOMA 1480 5000 C	Johnstown
WLTH 1400 500	Devis Lake	KTOK 1370 100 M	WJAC 1310 100
WMCA 570 1000	KDLR 1210 100	WKY 900 1000 N	Lancaster
WNEW 1250 1000	Fargo	Okmulgee	WGAL 1500 100 N
WNYC 810 1000	WDAY 940 1000 N	KHBG 1210 100	New Castle
WOV 1130 1000	Grand Forks	Ponca City	WKST 1250 250
WQXR 1550 1000	KFJM 1410 500	WBBZ 1200 100 M	Philadelphia
Olean	Jamestown	Shawnee	KYW 1020 10000 R
WHDL 1400 250	KRMC 1370 100	KGFF 1420 100M	WCAU 1170 50000 C
Pattsburg	Mandan	Tulsa	WDAS 1370 100
WMPF 1310 100 B	KGCU 1240 250	KOME 1310 250	WFIL 560 1000 B
Rochester	Minot	KTUL 1400 1000 C	WHAT 1310 100
WHAM 1150 50000 B	KLPM 1360 500	KVOO 1140 25000 N	WIP 610 1000
WHEC 1430 500 C	Valley City		WPEN 920 1000
WSAY 1210 100	KOVC 1500 100		WRAX 920 1000
Saranac Lake		<b>OREGON</b>	WTEL 1310 100
WNBZ 1290 100			
Schenectady	<b>OHIO</b>		
WGY 790 50000 R		Astoria	Pittsburgh
Syracuse	Akron	KAST 1370 100	KDKA 980 50000 B
WFBL 1360 1000 C	WADC 1320 1000 C	Baker	KQV 1380 500 C
WSYR 570 1000 B	WJW 1210 100	KBKR 1500 100	WCAE 1220 1000 R
WSYU 570 1000	Ashtabula	Bend	WJAS 1290 1000 C
Troy	WICA 940 250	KBND 1310 100	WWSW 1500 100
WHAZ 1300 1000	Canton	Corvallis	Reading
WTRY 950 1000	WIBC 1200 100	KOAC 550 1000	WEU 830 1000 R
Utica	Cincinnati	Eugene	WRAW 1310 100
WBX 1200 100 C	WCPO 1200 100	KORE 1420 100M	Seranton
White Plains	WKRC 550 1000 C	Klamath Falls	WGBI 880 500 C
WPAS 1210 100	WLW 700 500000 N	KFJI 1210 100	WQAN 880 500
Woodside	WSAI 1330 1000 N	La Grande	Sharon
WWRL 1500 100	Cleveland	KLBM 1420 100	WPIC 780 250
	WCLE 610 500M	Marshfield	Sunbury
	WGAR 1450 1000 C	KOOS 1200 100M	WKOK 1210 100
	WHK 1390 1000 B	Medford	Uniontown
	WTAM 1070 50000 R	KMED 1410 250 N	WMBS 1420 100
<b>NORTH CAROLINA</b>	Columbus	Portland	Wilkes-Barre
Asheville	WBNS 1430 1000 C	KALE 1300 1000M	WBAX 1210 100M
WWNC 570 1000 N	WCOL 1210 100 N	KBPS 1420 100	WBRE 1310 100 N
Charlotte	WHKC 640 500M	KEX 1180 5000 B	Williamsport
WBT 1080 50000 C	WOSU 570 750	KGW 620 1000 R	WRAK 1370 100
WSOC 1210 100 N	Dayton	KOIN 940 1000 C	York
Durham	WHIO 1260 1000 C	KWJJ 1040 500	YORK 1320 1000 N
WDNC 1500 100 C	WSMK 1380 250 C	KXL 1420 100	
Fayetteville	Lima	Reeseburg	<b>PUERTO RICO</b>
WFNC 1340 250	WBLV 1210 100	KRNR 1500 100M	Mayaguez
Gastonia	Pertsmouth	Salem	WPIA 1370 100
WCNC 1420 100	WPAY 1370 100	KSLM 1370 100M	Ponce
Greensboro	Toledo		WPRP 1420 100
WRIG 1440 1000 C	WSPD 1340 1000 B	<b>PENNSYLVANIA</b>	San Juan
High Point	WTOL 1200 100		WKAQ 1240 1000
WMPR 1200 100	Youngstown	Allentown	WNEL 1290 1000
Kinston	WFMJ 1420 100	WCBA 1440 500	<b>RHODE ISLAND</b>
WFTC 1200 100	WKBN 570 500 C	WSAN 1440 500 N	Providence
Raleigh	Zanesville	Altoona	WEAN 780 1000M
WPTF 680 5000 N	WALR 1210 100	WFBG 1310 100	
WRAL 1210 100		Easton	
Rocky Mount	<b>OKLAHOMA</b>	WEST 1200 100	
WEED 1420 100			
	Ada		

NORTH AMERICAN B. C. STATIONS BY LOCATIONS

WJAR 990 1000 R	<b>Amarillo</b>	<b>San Angelo</b>	<b>Richmond</b>
WPRO 630 500 C	KFDA 1500 100	KGKL 1370 100	WBBL 1210 100
	KGNC 1410 1000 N	<b>San Antonio</b>	WMBG 1350 500 R
<b>SOUTH CAROLINA</b>	<b>Austin</b>	KABC 1420 100M	WRNL 880 500
<b>Anderson</b>	KNOW 1500 100 C	KMAC 1370 100	WRTD 1500 100 B
WAIM 1200 100 C	KTBC 1120 1000	KONO 1370 100	WBVA 1110 5000 C
<b>Charleston</b>	<b>Beaumont</b>	KTSA 550 1000 C	<b>Roanoke</b>
WCSC 1360 500 N	KFDM 560 500 N	WOAI 1190 50000 N	WDBJ 930 1000 C
WTMA 1210 100	KRIC 1410 100M	<b>Sherman</b>	
<b>Columbia</b>	<b>Big Spring</b>	KRRV 1310 250M	<b>WASHINGTON</b>
WCOS 1370 100	KBST 1500 100M	<b>Temple</b>	<b>Aberdeen</b>
WIS 560 1000 N	<b>Brady</b>	KTEM 1370 250M	KXRO 1310 100M
WOLS 1200 100	KNEL 1500 250	<b>Texarkana</b>	<b>Bellingham</b>
<b>Florence</b>	<b>Brownsville</b>	KCMC 1420 100M	KVOS 1200 100M
WFBC 1200 100	KGFI 1500 100	<b>Tyler</b>	<b>Centralla</b>
<b>Greenville</b>	<b>College Station</b>	KGKB 1500 100M	KELA 1440 500M
WRKL 1300 1000 N	WTAW 1120 500	<b>Vernon</b>	<b>Everett</b>
<b>Rock Hill</b>	<b>Corpus Christi</b>	KVWC 1500 100	KRKO 1370 50M
WRKL 1500 100	KRIS 1330 500 N	<b>Waco</b>	<b>Longview</b>
<b>Spartanburg</b>	<b>Corsicana</b>	WACO 1420 100 C	KWLK 780 250
WSPA 920 1000	KAND 1310 100M	<b>Weslaco</b>	<b>Olympia</b>
	<b>Dallas</b>	KRGV 1260 1000 N	KGY 1210 100M
<b>SOUTH DAKOTA</b>	KRLD 1040 10000 C	<b>Wichita Falls</b>	<b>Pullman</b>
<b>Aberdeen</b>	WFAA 800 50000 N	KWFT 620 250	KWSC 1220 1000
KABR 1390 500	WRR 1280 500M		<b>Seattle</b>
<b>Brookings</b>	<b>Denton</b>	<b>UTAH</b>	<b>KEEN</b> 1370 100
KFDY 780 1000	KDNT 1420 100	<b>Cedar City</b>	KIRO 710 1000 C
<b>Pierre</b>	<b>Dublin</b>	KSUB 1310 100	KJR 970 5000 B
KGFX 630 200	KFPL 1310 100	<b>Logan</b>	KOL 1270 1000M
<b>Rapid City</b>	<b>El Paso</b>	KVNU 1200 100	KOMO 920 1000 R
KOBH 1370 100	KROD 1500 100	<b>Ogden</b>	KRSC 1120 250
WCAT 1200 100	KTSM 1310 100 N	<b>KLO</b> 1400 500 B	KTW 1220 1000
<b>Sioux Falls</b>	WDAH 1310 100	<b>Price</b>	KXA 760 250
KFLC 1200 100 N	<b>Fort Worth</b>	KEUB 1420 100	<b>Spokane</b>
KSOO 1110 5000 N	KFJZ 1370 100M	<b>Salt Lake City</b>	KPIO 1120 100
<b>Vermillion</b>	KGKO 570 1000 B	KDYL 1290 1000 R	KFPY 890 1000 C
KUSD 890 500	KTAT 1240 1000M	KSL 1130 50000 C	KGA 1470 5000 B
<b>Yankton</b>	WBAP 800 50000 N	KUTA 1500 100 N	KHQ 590 1000 R
WNAX 570 1000 C	<b>Galveston</b>		<b>Tacoma</b>
	KLUF 1370 100M	<b>VERMONT</b>	KMO 1330 1000M
<b>TENNESSEE</b>	<b>Greenville</b>	<b>Burlington</b>	KVI 570 1000 C
<b>Bristol</b>	KGVL 1200 100	WCAH 1200 100	<b>Vancouver</b>
WOPI 1500 100	<b>Houston</b>	<b>Rutland</b>	KVAN 880 250
<b>Chattanooga</b>	KPRC 920 1000 R	<b>St. Albans</b>	<b>Walla Walla</b>
WAPO 1420 100 N	KTRH 1290 1000 C	WQDM 1390 1000	KUJ 1370 100
WDOD 1280 1000 C	KXYZ 1440 1000 B	<b>Springfield</b>	<b>Wenatchee</b>
<b>Jackson</b>	<b>Huntsville</b>	WNBX 1260 1000 C	KIT 1250 250M
WTJS 1310 100	KSAM 1500 100	<b>Waterbury</b>	<b>Yakima</b>
<b>Johnson City</b>	<b>Kilgore</b>	WDEV 550 500	KPQ 1500 100
WJHL 1200 100	KOCA 1210 100		<b>WEST VIRGINIA</b>
<b>Knoxville</b>	<b>Laredo</b>	<b>VIRGINIA</b>	<b>Beckley</b>
WNOX 1010 1000 C	KPAB 1500 100	<b>Charlottesville</b>	WJLS 1210 100
WBOL 1310 100 N	<b>Longview</b>	WCHV 1420 100	<b>Bluefield</b>
<b>Memphis</b>	KFRO 1370 250M	<b>Danville</b>	WHLS 1410 500
WHBQ 1370 100	Lubbock	WBTM 1370 100	<b>Charleston</b>
WMC 780 1000 R	KFYO 1310 100M	<b>Harrisonburg</b>	WCHS 580 500 C
WMPS 1430 500 B	<b>Lufkin</b>	WSVA 550 500	WGVV 1500 100
WREC 600 1000 C	KRBA 1310 100	<b>Lynchburg</b>	<b>Clarksburg</b>
<b>Nashville</b>	<b>Midland</b>	WLVA 1200 100	WBLK 1370 100
WLAC 1470 5000 C	KRLH 1420 100	<b>Newport News</b>	<b>Fairmont</b>
WSIX 1210 100	<b>Palestine</b>	WGH 1310 100	WMMN 890 1000 C
WSM 650 50000 N	KNET 1420 100	<b>Norfolk</b>	<b>Huntington</b>
	<b>Pampa</b>	WTR 780 1000 N	WSAZ 1190 1000
<b>TEXAS</b>	KPDN 1310 100	<b>Petersburg</b>	<b>Parkersburg</b>
<b>Abilene</b>	<b>Paris</b>	WPIV 1210 100	WPAR 1420 100 C
KRBC 1420 100M	KPLT 1500 250M		<b>Wheeling</b>
	<b>Pecos</b>		WWVA 1160 5000 C
	KIUN 1370 100		
	<b>Port Arthur</b>		
	KPAC 1260 500		

NORTH AMERICAN B. C. STATIONS BY LOCATIONS

Williamson WBTH 1370 100
<b>WISCONSIN</b>
<b>Eau Claire</b>
WEAU 1050 1000
<b>Fond du Lac</b>
KFIZ 1420 100
<b>Green Bay</b>
WBYY 1200 100
WTAQ 1350 1000 C
<b>Janesville</b>
WCLO 1200 100
<b>LaCrosse</b>
WKBW 1380 1000 C
<b>Madison</b>
WHA 940 5000
WIBA 1280 1000 N
<b>Manitowoc</b>
WOMT 1210 100
<b>Milwaukee</b>
WEMP 1310 100
WISN 1120 250 C
WTMJ 620 1000 N
<b>Poynette</b>
WIBU 1210 100
<b>Racine</b>
WRJN 1370 100
<b>Rice Lake</b>
WJMC 1210 250
<b>Shaboygan</b>
WHBL 1300 250
<b>Stevens Point</b>
WLBL 900 5000
<b>Superior</b>
WDSM 1200 100
<b>Wausau</b>
WSAU 1370 100
<b>WYOMING</b>
<b>Casper</b>
KDFN 1440 500
<b>Rock Springs</b>
KVRS 1370 100
<b>Sheridan</b>
KWYO 1370 100
<b>BAHAMAS</b>
Nassau
ZNS 540 400
<b>CANADA</b>
<b>ALBERTA</b>
<b>Calgary</b>
CFAC 930 1000 F
CFCN 1030 10000
CJCJ 690 100 F
<b>Edmonton</b>
CFRN 960 100 F
CJCA 730 1000 F
CKUA 580 500 F
<b>Grande Prairie</b>
CFGP 1200 100
<b>Lethbridge</b>
CJOC 950 100 F

<b>BRIT. COLUMBIA</b>
<b>Chilliwack</b>
CHWK 780 100 F
<b>Kamloops</b>
CFJC 880 1000 F
<b>Kelowna</b>
CKOV 630 100 F
<b>Prince Rupert</b>
CFPR 580 50
<b>Trail</b>
CJAT 910 1000 F
<b>Vancouver</b>
CBR 1100 5000 F
CJOR 600 500
CKCD 1010 100
CKFC 1410 50
CKMO 1410 100
CKWX 1010 100 F
<b>Victoria</b>
CFCT 1450 500
<b>MANITOBA</b>
<b>Brandon</b>
CKX 1120 1000 F
<b>Flin Flon</b>
CFAR 1370 100
<b>Winnipeg</b>
CJRC 630 1000 F
CKY 910 15000 F
<b>NEW BRUNSWICK</b>
<b>Fredericton</b>
CFNB 550 500 F
<b>Moncton</b>
CKCV 1370 100 F
<b>Sackville</b>
CBA 1050 50000
<b>St. John</b>
CHSJ 1120 100 F
<b>N. W. TERRITORY</b>
<b>Aklavik</b>
CJCU 1210 50
<b>NOVA SCOTIA</b>
<b>Glace Bay</b>
VAS 685 2000
<b>Halifax</b>
CHNS 930 1000 F
<b>Sydney</b>
CJCB 1240 1000 F
<b>Wolfville</b>
CKIC 1010 50
<b>Yarmouth</b>
CJLS 1310 100 F
<b>ONTARIO</b>
<b>Brantford</b>
CKPK 930 100
<b>Chatham</b>
CFCO 630 100 F
<b>Cobalt</b>
CKMC 1210 50
<b>Fort William</b>
CKPR 580 100 F

<b>Hamilton</b>
CHML 1010 100 F
CKOC 1120 500 F
<b>Kenora</b>
CKKA 1420 100
<b>Kingston</b>
CFRC 1510 100 F
<b>London</b>
CFPL 730 100 F
<b>North Bay</b>
CFCH 930 100 F
CJKL 1310 100 F
CKGB 1420 100 F
<b>Ottawa</b>
CBO 880 1000 F
CKCO 1010 100 F
<b>Owen Sound</b>
CFOS 1370 100
<b>Prescott</b>
CFLC 930 100
<b>St. Catharines</b>
CKTB 1200 100 F
<b>Sault Ste. Marie</b>
CJIC 1500 100 F
<b>Stratford</b>
CJCS 1210 50
<b>Sudbury</b>
CKSO 780 1000 F
<b>Toronto</b>
CBL 840 50000 F
CBY 960 500 F
CFRB 890 10000 C
CKCL 580 100 F
<b>Waterloo</b>
CKCR 1510 100
<b>Windsor</b>
CKLW 1030 5000 F
<b>Winham</b>
CKNX 1200 100
<b>PRINCE EDWARD ISLAND</b>
<b>Charlottetown</b>
CFCY 630 1000 F
CECK 1310 50
<b>Summerside</b>
CHGS 1450 50 F
<b>QUEBEC</b>
<b>Chloutilm</b>
CBJ 1120 100 F
<b>Hull</b>
CKKH 1210 100 F
<b>Montreal</b>
CBF 910 50000 N
CBM 1050 5000 F
CFCF 600 500 B
CHLP 1120 100 F
CKAC 730 5000 C
<b>New Carlisle</b>
CHNC 610 1000 F
<b>Quebec</b>
CHRC 580 100
CKCV 1310 100 F
CBV 950 1000 F
<b>Rimouski</b>
CJBR 1030 1000 F

<b>Rouyn</b>
CKRN 1370 100
<b>St. Anne de la Pocatiere</b>
CHGB 1200 100
<b>Sherbrooke</b>
CHLT 1210 100
<b>Three Rivers</b>
CHLN 1420 100
<b>SASKATCHEWAN</b>
<b>Moose Jaw</b>
CHAB 1200 100 F
<b>Prince Albert</b>
CKBI 1210 100 F
<b>Regina</b>
CJRM 540 1000 F
CKCK 1010 1000 F
<b>Saskatoon</b>
CBK 540 50000
CFQC 840 1000 F
<b>Yorkton</b>
CJGX 1390 100 F
<b>COSTA RICA</b>
<b>San Jose</b>
TIGH 725 600
TIJL 775 500
TILS 880 1000
TIPG 625 2000
TIRH 950 1000
TIRS 915 250
TIX 650 1000
TIXD 800 1000
<b>CUBA</b>
<b>Bayamo</b>
CMKL 950 200
<b>Caibarien</b>
CMHD 1270 200
<b>Camaguey</b>
CMJA 860 200
CMJC 1390 200
CMJE 1230 200
CMJF 930 200
CMJK 1290 200
CMJW 1070 200
CMJX 740 200
<b>Cardenas</b>
CMGE 1370 200
<b>Ciego de Avila</b>
CMJH 1360 200
CMJI 1130 200
CMJO 1260 200
<b>Cienfuegos</b>
CMHJ 1160 200
CMHM 1450 200
CMHX 1480 200
<b>Cruces</b>
CMHK 1210 200
<b>Guantanamo</b>
CMKS 710 200
<b>Guines</b>
CM9RT 1580 200
<b>Havana</b>
CMBC 1140 200
CMBD 550 200
CMBG 690 200
CMBF 1560 5000

## NORTH AMERICAN B. C. STATIONS BY LOCATIONS

CMBG	690	200
CMBH	1600	5000
CMBL	750	200
CMBQ	1320	5000
CMBS	1170	200
CMBX	1080	200
CMBY	1440	200
CMBZ	940	200
CMC	1530	200
CMCA	1350	200
CMCB	1230	200
CMCD	630	15000
CMCF	810	5000
CMCG	1290	200
CMCJ	1110	200
CMCK	970	5000
CMCL	730	10000
CMCM	850	200
CMCO	1200	200
CMCP	1050	200
CMCQ	1410	200
CMCR	660	200
CMCU	780	200
CMCW	1380	200
CMCX	1470	200
CMCY	570	15000
CMK	720	200
CMOA	910	200
CMOX	1500	200
CMQ	1010	25000 N
CMW	880	1400
CMX	1260	200
<b>Holguin</b>		
CMKF	1460	250
CMKO	1280	200
<b>Manzanillo</b>		
CMKM	1080	200
<b>Matanzas</b>		
CMGF	1120	200
CMGH	790	200
<b>Moron</b>		
CMJP	1420	200
<b>Palma Soriano</b>		
CMKZ	1430	200
<b>Pinar del Rio</b>		
CMAB	1240	200
<b>Placetas</b>		
CMHP	1100	200
<b>Sagua la Grande</b>		
CMHA	1090	200
<b>Sancti Spiritus</b>		
CMBH	1240	200
<b>Santa Clara</b>		
CMHI	1060	200
CMHW	680	200
<b>Santiago</b>		
CMKC	1250	200
CMKD	910	10000
CMKG	1150	200
CMKQ	1490	200
CMKR	1400	200
CMKW	750	200
CMKX	1190	200
<b>Trinidad</b>		
CMHT	920	200
<b>DOMINICAN REPUBLIC</b>		
<b>Ciudad Trujillo</b>		
HIN	1090	740

HIX	800	800
HIT	1050	50
<b>EL SALVADOR</b>		
<b>San Salvador</b>		
YSS	640	500

<b>GUATEMALA</b>		
<b>GuatemalaCity</b>		
TGW	1520	1000
TGX	1400	...
TGI	1310	...
<b>Quezaltenango</b>		
TGQ	1450	200

<b>HONDURAS</b>		
<b>Tegucigalpa</b>		
HRN	1250	50

<b>MEXICO</b>		
<b>AGUASCALIENTES</b>		
<b>Aguascalientes</b>		
XEBI	1000	250

<b>BAJA CALIFORNIA</b>		
<b>Mexicali</b>		
XEAA	750	200
XEAO	660	250
XECL	960	1000
<b>Rosarito Beach</b>		
XERB	1090	150000
<b>Tijuana</b>		
XEBG	820	1000
XEAC	980	5000
XEC	1150	100
XELO	730	50000
XEMO	860	5000

<b>CHIHUAHUA</b>		
<b>Chihuahua</b>		
XEBU	1240	50
XEBW	1340	250
XEFI	1440	250
XEM	1380	500
<b>Juarez</b>		
XEF	1450	100
XEFV	1210	50
XEJ	1020	1000
XEP	1160	500
<b>Parral</b>		
XEAT	1210	250

<b>COAHUILA</b>		
<b>Piedras Negras</b>		
XEMU	580	250
XEPN	730	100000
<b>Sabinas</b>		
XEBX	640	250
<b>Saltillo</b>		
XEAS	1160	100
<b>Torreón</b>		

XETE	1310	500
<b>Villa Acuna</b>		
XEDH	1340	200
XERA	840	250000

<b>DISTRITO FEDERAL</b>		
<b>Gral. Anaya</b>		
XEDA	1220	200
<b>Mexico City</b>		
XEAI	1250	500
XEAL	660	1000
XEB	1030	10000
XEBS	1340	200
XEBZ	810	100
XEDP	1080	500
XEFO	940	5000
XEJP	1130	100
XEK	990	100
XEL	1150	250
XELZ	1370	100
XEN	780	1000
XEQ	710	50000
XERC	870	500
XERH	1480	500
XEW	890	100000
XEXX	1170	1000

<b>DURANGO</b>		
<b>Durango</b>		
XEBP	1150	250
XEE	1210	50

<b>GUANAJUATO</b>		
<b>Irapuato</b>		
XEBO	1310	25
<b>Leon</b>		
XEKL	1240	500

<b>JALISCO</b>		
<b>Guadalajara</b>		
XED	1160	2500
<b>Guzman</b>		
XEBA	1080	20

<b>MEXICO</b>		
<b>Texcoco</b>		
XEXE	1270	17
<b>Toluca</b>		
XECH	1490	250

<b>MICHOACAN</b>		
<b>Morelia</b>		
XEI	1370	125

<b>NUEVO LEON</b>		
<b>Monterrey</b>		
XEFB	870	200
XEG	1230	250
XEH	720	250
XET	690	5000
XEX	1310	500

<b>PUEBLA</b>		
<b>Puebla</b>		
XETH	1210	100

<b>SAN LUIS POTOSI</b>		
<b>San Luis Potosi</b>		
XECZ	1370	100

<b>SINALOA</b>		
<b>Mazatlan</b>		
XEBL	1220	50

<b>SONORA</b>		
<b>Cananea</b>		
XEFQ	1010	50
<b>Guaymas</b>		
XEDR	1490	100
<b>Hermosillo</b>		
XEBH	930	500
<b>Nogales</b>		
XEAF	990	750
<b>Oregon</b>		
XEAP	1340	50

<b>TAMAULIPAS</b>		
<b>Matamoros</b>		
XEAM	750	25
<b>Nuevo Laredo</b>		
XEBK	1080	100
XEDF	810	100
XEFE	980	250
XENT	910	150000
<b>Reynosa</b>		
XEAW	960	100000
<b>Tampico</b>		
XECA	1230	250
XEFW	1310	300
XES	990	250

<b>VERACRUZ</b>		
<b>Cordoba</b>		
XEAG	1310	10
<b>Jalapa</b>		
XEXB	1270	250
<b>Minatitlan</b>		
XEDW	1150	20
<b>Orizaba</b>		
XEXD	1340	350
<b>Veracruz</b>		
XETF	1220	12
XEU	1010	250

<b>YUCATAN</b>		
<b>Merida</b>		
XEFC	1340	100
XEME	1240	50
XEZ	630	500

<b>MIQUELON</b>		
<b>St. Pierre</b>		
FQN	609	250
<b>NEWFOUNDLAND</b>		
<b>St. John's</b>		
VOAC	1065	40
VOCM	1006	200
VOGY	840	400
VONF	1195	500
VOWR	681	500

NORTH AMERICAN B. C. STATIONS BY CALLS

CBA	1050	50000	Sackville, N. B.	CHLT	1210	100	Sherbrooke, P. Q.	CKIC	1010	50	Wolfville, N. S.
CBF	910	50000	Montreal, P. Q.	CHML	1010	100	Hamilton, Ont.	CKLW	1030	5000	Windsor, Ont.
CBJ	1120	100	Chicoutimi, P. Q.	CHNC	610	1000	New Carlisle, P. Q.	CKMC	1210	50	Cobalt, Ont.
CBK	540	50000	Saskatoon, Sask.	CHNS	930	1000	Halifax, N. S.	CKMO	1410	100	Vancouver, B. C.
CBL	840	50000	Toronto, Ont.	CHRC	580	100	Quebec, P. Q.	CKNX	1200	100	Wingham, Ont.
CBM	1050	5000	Montreal, P. Q.	CHSJ	1120	100	St. John, N. B.	CKOC	1120	500	Hamilton, Ont.
CBO	880	1000	Ottawa, Ont.	CHWK	780	100	Chilliwack, B. C.	CKOV	630	100	Kelowna, B. C.
CBR	1100	5000	Vancouver, B. C.	CJAT	910	1000	Trail, B. C.	CKPC	930	100	Brantford, Ont.
CBV	950	1000	Quebec, P. Q.	CJBR	1030	1000	Rimouski, P. Q.	CKPR	580	100	Fort William, Ont.
CBY	960	500	Toronto, Ont.	CJCA	730	1000	Edmonton, Alta.	CKRN	1370	100	Rouyn, P. Q.
CFAC	930	1000	Calgary, Alta.	CJCB	1240	1000	Sydney, N. S.	CKSO	780	1000	Sudbury, Ont.
CFAR	1370	100	Flin Flon, Man.	CJCF	690	100	Calgary, Alta.	CKTB	1200	100	St. Catharines, Ont.
CFCF	600	500	Montreal, P. Q.	CJCS	1210	50	Stratford, Ont.	CKUA	580	500	Edmonton, Alta.
CFCH	930	100	North Bay, Ont.	CJCU	1210	50	Aklavik, N. W. T.	CKWX	1010	100	Vancouver, B. C.
CFCN	1030	10000	Calgary, Alta.	CJGX	1390	100	Yorkton, Sask.	CKX	1120	1000	Brandon, Man.
CFCO	630	100	Chatham, Ont.	CJIC	1500	100	S. Ste. Marie, Ont.	CKY	910	15000	Winnipeg, Man.
CFCT	1450	500	Victoria, B. C.	CJKL	1310	100	North Bay, Ont.	CMAB	1240	200	Pinar del Rio, Cuba
CFCY	630	1000	Charlottetown, P.E.I.	CJLS	1310	100	Yarmouth, N. S.	CMBC	1140	200	Havana, Cuba
CFGP	1200	100	Grande Prairie, Alta.	CJOC	950	100	Lethbridge, Alta.	CMBD	550	500	Havana, Cuba
CFJC	800	1000	Kamloops, B. C.	CJOR	600	500	Vancouver, B. C.	CMBF	1560	5000	Havana, Cuba
CFLC	930	100	Prescott, Ont.	CJRC	630	1000	Winnipeg, Man.	CMBG	690	200	Havana, Cuba
CFNB	550	500	Fredericton, N. B.	CJRM	540	1000	Regina, Sask.	CMBH	1600	5000	Havana, Cuba
CFOS	1370	100	Owen Sound, Ont.	CKAC	730	5000	Montreal, P. Q.	CMBL	750	200	Havana, Cuba
CFPL	730	100	London, Ont.	CKBI	1210	100	Prince Albert, Sask.	CMBQ	1320	5000	Havana, Cuba
CFPR	580	50	Prince Rupert, B. C.	CKKA	1420	100	Kenora, Ont.	CMBS	1170	200	Havana, Cuba
CFQC	840	1000	Saskatoon, Sask.	CKCD	1010	100	Vancouver, B. C.	CMBX	1080	200	Havana, Cuba
CFRB	690	10000	Toronto, Ont.	CKCH	1210	100	Hull, P. Q.	CMBY	1440	200	Havana, Cuba
CFRC	1510	100	Kingston, Ont.	CKCK	1010	1000	Regina, Sask.	CMCZ	940	200	Havana, Cuba
CFRN	960	100	Edmonton, Alta.	CKCL	580	100	Toronto, Ont.	CMC	1530	200	Havana, Cuba
CHAB	1200	100	Moose Jaw, Sask.	CKCO	1010	100	Ottawa, Ont.	CMCA	1350	200	Havana, Cuba
CHCK	1310	50	Charlottetown, P.E.I.	CKCR	1510	100	Waterloo, Ont.	CMCB	1230	200	Havana, Cuba
CHGB	1200	100	St. Ann, P. Q.	CKCV	1310	100	Quebec, P. Q.	CMCD	630	15000	Havana, Cuba
CHGS	1450	50	Summerside, P.E.I.	CKCW	1370	100	Moncton, N. B.	CMCF	810	5000	Havana, Cuba
CHLN	1420	100	Three Rivers, P. Q.	CKFC	1410	50	Vancouver, B. C.	CMCG	1290	200	Havana, Cuba
CHLP	1120	100	Montreal, P. Q.	CKGB	1420	100	North Bay, Ont.	CMCJ	1110	200	Havana, Cuba

## NORTH AMERICAN B. C. STATIONS BY CALLS

CMCK	970	5000	CMJX	740	200	KARM	1310	100
Havana, Cuba			Camaguey, Cuba			Fresno, Calif.		
CMCL	730	10000	CMK	720	200	KASA	1210	100
Havana, Cuba			Havana, Cuba			Elk Cly, Okla.		
CMCM	850	200	CMKC	1250	200	KAST	1370	100
Havana, Cuba			Santiago, Cuba			Astoria, Ore.		
CMCO	1200	200	CMKD	910	1000	KATE	1420	250
Havana, Cuba			Santiago, Cuba			Albert Lea, Minn.		
CMCP	1050	200	CMKF	1460	250	KAWM	1500	100
Havana, Cuba			Holguin, Cuba			Gallup, N. Mex.		
CMCQ	1410	200	CMKG	1150	200	KBIX	1500	100
Havana, Cuba			Santiago, Cuba			Muskogee, Okla.		
CMCR	660	200	CMKL	950	200	KBKR	1500	100
Havana, Cuba			Bayamo, Cuba			Baker, Ore.		
CMCU	780	200	CMKM	1080	200	KBND	1310	100
Havana, Cuba			Manzanillo, Cuba			Bend, Ore.		
CMCW	1380	200	CMKO	1280	200	KBPS	1420	100
Havana, Cuba			Holguin, Cuba			Portland, Ore.		
CMCX	1470	200	CMKQ	1490	200	KBST	1500	100
Havana, Cuba			Santiago, Cuba			Big Spring, Texas		
CMCY	590	15000	CMKR	1400	200	KBTM	1200	100
Havana, Cuba			Santiago, Cuba			Jonesboro, Ark.		
CMGE	1370	200	CMKS	710	200	KCKN	1310	100
Cardenas, Cuba			Guantanamo, Cuba			Kansas City, Kans.		
CMGF	1120	200	CMKW	770	200	KCMC	1420	100
Matanzas, Cuba			Santiago, Cuba			Texasarkana, Texas		
CMGH	790	200	CMKX	1190	200	KCMO	1370	100
Matanzas, Cuba			Santiago, Cuba			Kansas City, Mo.		
CMHA	1090	200	CMKZ	1430	200	KCRC	1360	250
Sagua la Grande, Cuba			Palma Sorlano, Cuba			Enid, Okla.		
CMHB	1240	200	CMOA	910	200	KCRJ	1310	100
Sancti Spiritus, Cuba			Havana, Cuba			Jerome, Ariz.		
CMHD	1270	200	CMOX	1500	200	KDAL	1500	100
Caibarien, Cuba			Havana, Cuba			Duluth, Minn.		
CMHI	1060	200	CMQ	1010	25000	KDB	1500	100
Santa Clara, Cuba			Havana, Cuba			Santa Barbara, Calif.		
CMHJ	1160	200	CMW	880	1400	KDFN	1440	500
Cienfuegos, Cuba			Havana, Cuba			Casper, Wyo.		
CMHK	1210	200	CMX	1260	200	KDKA	980	50000
Cruces, Cuba			Havana, Cuba			Pittsburgh, Pa.		
CMHM	1450	200	CM9RT	1580	200	KDLR	1210	100
Cienfuegos, Cuba			Guines, Cuba			Devils Lake, N. D.		
CMHP	1100	200	FQN	609	250	KDNT	1420	100
Placetas, Cuba			St. Pierre, Miquelon			Denton, Texas		
CMHT	920	200	HIN	1090	740	KDON	1210	100
Trinidad, Cuba			Ciudad Trujillo, D. R.			Monterey, Calif.		
CMHW	680	200	HIT	1050	50	KDTH	1340	500
Santa Clara, Cuba			Ciudad Trujillo, D. R.			Dubuque, Iowa		
CMHX	1480	200	HIX	800	800	KDYL	1290	1000
Cienfuegos, Cuba			Ciudad Trujillo, D. R.			Salt Lake City, Utah		
CMJA	860	200	HP50	1440	....	KECA	1430	1000
Camaguey, Cuba			Panama City, Panama			Los Angeles, Calif.		
CMJC	1390	200	HRN	1250	50	KEEN	1370	100
Camaguey, Cuba			Tegucigalpa, Hon.			Seattle, Wash.		
CMJE	1230	200	KABC	1420	100	KEHE	780	1000
Camaguey, Cuba			San Antonio, Texas			Los Angeles, Calif.		
CMJF	930	200	KABR	1390	500	KELA	1440	500
Camaguey, Cuba			Aberdeen, S. Dak.			Centralia, Wash.		
CMJH	1360	200	KADA	1200	100	KELD	1370	100
Ciego de Avila, Cuba			Ada, Okla.			El Dorado, Ark.		
CMJI	1130	200	KALB	1210	100	KELO	1200	100
Ciego de Avila, Cuba			Alexandria, La.			Sioux Falls, S. Dak.		
CMJK	1290	200	KALE	1300	1000	KERN	1370	100
Camaguey, Cuba			Portland, Ore.			Bakersfield, Calif.		
CMJO	1260	200	KAND	1310	100	KEUB	1420	100
Ciego de Avila, Cuba			Corsicana, Texas			Price, Utah		
CMJP	1420	200	KANS	1210	100	KEX	1180	5000
Camaguey, Cuba			Wichita, Kans.			Portland, Ore.		
CMJW	1070	200	KARK	890	500			
Camaguey, Cuba			Little Rock, Ark.					

## NORTH AMERICAN B. C. STATIONS BY CALLS

KFAB	770	10000	KFUO	550	500	KGIW	1420	100
Lincoln, Neb.			St. Louis, Mo.			Alamosa, Colo.		
KFAC	1300	1000	KFVD	1600	1000	KGKB	1500	100
Los Angeles, Calif.			Los Angeles, Calif.			Tyler, Texas		
KFAM	1420	100	KFVS	1210	100	KGKL	1370	100
St. Cloud, Minn.			Cape Girardeau, Mo.			San Angelo, Texas		
KFAR	610	1000	KFWB	950	1000	KGKO	570	1000
Fairbanks, Alaska			Los Angeles, Calif.			Fort Worth, Texas		
KFBB	1280	1000	KFXD	1200	100	KGKY	1500	100
Great Falls, Mont.			Nampa, Idaho			Scottsbluff, Neb.		
KFBI	1050	5000	KFXJ	1200	100	KGLO	1210	100
Abilene, Kans.			Grand Junction, Colo.			Mason City, Iowa		
KFBK	1490	10000	KFXM	1210	100	KGLU	1420	100
Sacramento, Calif.			San Bernardino, Calif.			Safford, Ariz.		
KFDA	1500	100	KFYO	1310	100	KGMB	1320	1000
Amarillo, Texas			Lubbock, Texas			Honolulu, T. H.		
KFDM	560	500	KFYR	550	1000	KGNC	1410	1000
Beaumont, Texas			Bismarck, N. D.			Amarillo, Texas		
KFDY	780	1000	KGA	1470	5000	KGNF	1430	1000
Brookings, S. D.			Spokane, Wash.			North Platte, Neb.		
KFEL	920	500	KGAR	1370	100	KGNO	1340	250
Denver, Colo.			Tucson, Ariz.			Dodge City, Kans.		
KFEQ	680	2500	KGB	1330	1000	KGO	790	7500
St. Joseph, Mo.			San Diego, Calif.			San Francisco, Calif.		
KFGQ	1370	100	KGBU	900	500	KGU	750	2500
Boone, Iowa			Ketchikan, Alaska			Honolulu, T. H.		
KFH	1300	1000	KGBX	1230	500	KGVL	1420	100
Wichita, Kans.			Springfield, Mo.			Greenville, Texas		
KFI	640	50000	KGCA	1270	100	KGVO	1260	1000
Los Angeles, Calif.			Decorah, Iowa			Missoula, Mont.		
KFIO	1120	100	KGCI	1200	100	KGW	620	1000
Spokane, Wash.			Coeur d'Alene, Idaho			Portland, Ore.		
KFIZ	1420	100	KGCU	1240	250	KGY	1210	100
Fond du Lac, Wis.			Mandan, N. D.			Olympia, Wash.		
KFJB	1200	100	KGDX	1450	1000	KHBC	1400	250
Marshalltown, Iowa			Wolf Point, Mon.			Hilo, T. H.		
KFJI	1210	100	KGDE	1200	100	KHBB	1210	100
Klamath Falls, Ore.			Fergus Falls, Minn.			KHJ	900	1000
KFJM	1410	500	KGDM	1100	1000	Los Angeles, Calif.		
Grand Forks, N. D.			Stockton, Calif.			KHQ	590	1000
KFJZ	1370	100	KGEK	1200	100	Spokane, Wash.		
Fort Worth, Texas			Sterling, Colo.			KHSL	1260	250
KFKA	880	500	KGER	1360	1000	Chico, Calif.		
Greeley, Colo.			Long Beach, Calif.			KHUB	1310	250
KFKU	1220	1000	KGEZ	1310	100	Watsonville, Calif.		
Lawrence, Kans.			Kalispell, Mont.			KICA	1370	100
KFNF	890	500	KGFF	1420	100	Clovis, N. M.		
Shenandoah, Iowa			Shawnee, Okla.			KID	1320	500
KFOR	1210	100	KGFI	1500	100	Idaho Falls, Idaho		
Lincoln, Neb.			Brownsville, Tex.			KIDO	1350	1000
KFOX	1250	1000	KGFJ	1200	100	Boise, Idaho		
Long Beach, Calif.			Los Angeles, Calif.			KIDW	1420	100
KFPL	1310	100	KGFL	1370	100	Lamar, Colo.		
Dublin, Texas			Roswell, N. Mex.			KIEM	1450	500
KFPW	1210	100	KGFW	1310	100	Eureka, Calif.		
Fort Smith, Ark.			Kearney, Neb.			KIEV	850	250
KFPY	890	1000	KGFX	630	200	Glendale, Calif.		
Spokane, Wash.			Pierre, S. D.			KINY	1430	250
KFQD	780	250	KGGF	1010	1000	Juneau, Alaska		
Anchorage, Alaska			Coffeyville, Kans.			KIRO	710	1000
KFRC	610	1000	KGGM	1230	1000	Seattle, Wash.		
San Francisco, Calif.			Albuquerque, N. M.			KIT	1250	250
KFRO	1370	250	KGHF	1320	500	Yakima, Wash.		
Longview, Texas			Pueblo, Colo.			KITE	1530	1000
KFRU	630	500	KGHI	1200	100	Kansas City, Mo.		
Columbia, Mo.			Little Rock, Ark.			KIUL	1210	100
KFSD	600	1000	KGHL	780	1000	Garden City, Kans.		
San Diego, Calif.			Billings, Mont.			KIUN	1370	100
KFSG	1120	500	KGIR	1340	1000	Pecos, Texas		
Los Angeles, Calif.			Butte, Mont.					

## NORTH AMERICAN B. C. STATIONS BY CALLS

KIUP	1370	100	KOH	1380	500	KRKD	1120	500
Durango, Colo.			Reno, Nev.			Los Angeles, Calif.		
KJBS	1070	500	KOIL	1260	1000	KRKO	1370	50
San Francisco, Calif.			Omaha, Neb.			Everett, Wash.		
KJR	970	5000	KOIN	940	1000	KRLC	1390	250
Seattle, Wash.			Portland, Ore.			Lewiston, Idaho		
KLAH	1210	100	KOKO	1370	100	KRLD	1040	10000
Carlsbad, N. Mex.			La Junta, Colo.			Dallas, Texas		
KLBM	1420	100	KOL	1270	1000	KRLH	1420	100
La Grande, Ore.			Seattle, Wash.			Midland, Texas		
KLCN	1290	100	KOMA	1480	5000	KRMC	1370	100
Blytheville, Ark.			Oklahoma City, Okla.			Jamestown, N. Dak.		
KLO	1400	500	KOME	1310	250	KRMD	1310	100
Ogden, Utah			Tulsa, Okla.			Shreveport, La.		
KLPM	1360	500	KOMO	920	1000	KRNR	1500	100
Minot, N. D.			Seattle, Wash.			Roseburg, Ore.		
KLRA	1390	1000	KONO	1370	100	KRNT	1320	1000
Little Rock, Ark.			San Antonio, Texas			Des Moines, Iowa		
KLS	1280	250	KOOS	1200	100	KROC	1310	100
Oakland, Calif.			Marshfield, Ore.			Rochester, Minn.		
KLUF	1370	100	KORE	1420	100	KROD	1500	100
Galveston, Texas			Engene, Ore.			El Paso, Texas		
KLX	880	1000	KOTN	1500	100	KROW	930	1000
Oakland, Calif.			Pine Bluff, Ark.			Oakland, Calif.		
KLZ	560	1000	KOVC	1500	100	KROY	1210	100
Denver, Colo.			Valley City, N. Dak.			Sacramento, Calif.		
KMA	930	1000	KOY	1390	1000	KRQA	1310	100
Shenandoah, Iowa			Phoenix, Ariz.			Santa Fe, N. Mex.		
KMAC	1370	100	KPAB	1500	100	KRRV	1310	250
San Antonio, Texas			Laredo, Texas			Sherman, Texas		
KMBC	950	1000	KPAC	1260	500	KRSC	1120	250
Kansas City, Mo.			Port Arthur, Texas			Seattle, Wash.		
KMED	1410	250	KPDN	1310	100	KSAC	560	500
Medford, Ore.			Pampa, Texas			Manhattan, Kans.		
KMJ	580	1000	KPFA	1210	100	KSAL	1500	100
Fresno, Calif.			Helena, Mont.			Salina, Kans.		
KMLB	1200	100	KPLC	1500	100	KSAM	1500	100
Monroe, La.			Lake Charles, La.			Huntsville, Texas		
KMMJ	740	1000	KPLT	1500	250	KSAN	1420	100
Clay Center, Neb.			Paris, Texas			San Francisco, Calif.		
KMO	1330	1000	KPMC	1550	1000	KSCJ	1330	1000
Tacoma, Wash.			Bakersfield, Calif.			Sioux City, Iowa		
KMOX	1090	50000	KPO	680	50000	KSD	550	1000
St. Louis, Mo.			San Francisco, Calif.			St. Louis, Mo.		
KMPC	710	500	KPOF	880	1000	KSEI	900	250
Beverly Hills, Calif.			Denver, Colo.			Pocatello, Idaho		
KMTR	570	1000	KPPC	1210	100	KSFO	560	1000
Los Angeles, Calif.			Pasadena, Calif.			San Francisco, Calif.		
KNEL	1500	250	KPQ	1500	100	KSL	1130	50000
Brady, Texas			Wenatchee, Wash.			Salt Lake City, Utah		
KNET	1420	100	KPRC	920	1000	KSLM	1370	100
Palestine, Texas			Houston, Texas			Salem, Ore.		
KNOW	1500	100	KQV	1380	500	KSO	1430	1000
Austin, Texas			Pittsburgh, Pa.			Des Moines, Iowa		
KNX	1050	50000	KQW	1010	1000	KS00	1110	5000
Los Angeles, Calif.			San Jose, Calif.			Sioux Falls, S. Dak.		
KOA	830	50000	KRBA	1310	100	KSRO	1310	100
Denver, Colo.			Lufkin, Texas			Santa Rosa, Calif.		
KOAC	550	1000	KRBC	1420	100	KSTP	1460	10000
Corvallis, Ore.			Abilene, Texas			St. Paul, Minn.		
KOAM	790	1000	KRBM	1420	100	KSUB	1310	100
Pittsburg, Kans.			Bozeman, Mont.			Cedar City, Utah		
KOB	1180	10000	KRE	1370	100	KSUN	1200	100
Albuquerque, N. M.			Berkeley, Calif.			Lowell, Ariz.		
KOBH	1370	100	KRGV	1260	1000	KTAR	620	1000
Rapid City, S. Dak.			Weslaco, Texas			Phoenix, Ariz.		
KOCA	1210	100	KRIC	1420	100	KTAT	1240	1000
Kilgore, Texas			Beaumont, Texas			Fort Worth, Texas		
KOCY	1310	100	KRIS	1330	500	KTBC	1120	1000
Oklahoma City, Okla.			Corpus Christi, Tex.			Austin, Texas		



NORTH AMERICAN B. C. STATIONS BY CALLS

KTBS 1450 1000	KVOX 1310 100	TGI 1310 ....
Shreveport, La.	Moorhead, Minn.	Guatemala City, Guat.
KTEM 1370 250	KVRS 1370 100	TIGH 725 600
Temple, Texas	Rock Springs, Wyo.	San Jose, Costa Rica
KTFI 1240 1000	KVSO 1210 100	TILJ 775 500
Twin Falls, Idaho	Ardmore, Okla.	San Jose, Costa Rica
KTHS 1060 10000	KVWC 1500 100	TILS 880 1000
Hot Springs, Ark.	Vernon, Texas	San Jose, Costa Rica
KTKC 1190 250	KWAL 1420 100	TIPG 625 2000
Visalia, Calif.	Wallace, Idaho	San Jose, Costa Rica
KTMS 1220 500	KWBG 1420 100	TIRH 950 1000
Santa Barbara, Calif.	Hutchinson, Kans.	San Jose, Costa Rica
KTOH 1500 100	KWEW 1500 100	TIRS 915 250
Lihue, Hawaii	Hobbs, N. Mex.	San Jose, Costa Rica
KTOK 1370 100	KWFT 620 250	TIX 650 1000
Oklahoma City, Okla.	Wichita Falls, Texas	San Jose, Costa Rica
KTRB 740 250	KWG 1200 100	TIXD 800 1000
Modesto, Calif.	Stockton, Calif.	San Jose, Costa Rica
KTRH 1290 1000	KWJB 1210 100	VAS 685 2000
Houston, Texas	Globe, Ariz.	Glance Bay, N. S.
KTRI 1420 100	KWJJ 1040 500	VOAC 1065 40
Sioux City, Iowa	Portland, Ore.	St. John's Nfld.
KTSA 550 1000	KWK 1350 1000	VOCM 1006 200
San Antonio, Texas	St. Louis, Mo.	St. John's Nfld.
KTSM 1310 100	KWKH 1100 10000	VOGY 840 400
El Paso, Texas	Shreveport, La.	St. John's Nfld.
KTSW 1370 100	KWLC 1270 100	VONF 1195 500
Emporia, Kans.	Decorah, Iowa	St. John's Nfld.
KTUL 1400 1000	KWLK 780 250	VOWR 681 500
Tulsa, Okla.	Longview, Wash.	St. John's Nfld.
KTW 1220 1000	KWNO 1200 250	WAAB 1410 500
Seattle, Wash.	Winona, Minn.	Boston, Mass.
KUJ 1370 100	KWOC 1310 100	WAAF 920 1000
Walla Walla, Wash.	Poplar Bluff, Mo.	Chicago, Ill.
KUMA 1420 100	KWOS 1310 100	WAAT 940 500
Yuma, Ariz.	Jefferson City, Mo.	Jersey City, N. J.
KUOA 1260 5000	KWSC 1220 1000	WAAW 660 500
Siloam Springs, Ark.	Pullman, Wash.	Omaha, Neb.
KUSD 890 500	KWTO 560 5000	WABC 860 50000
Vermillion, S. Dak.	Springfield, Mo.	New York, N. Y.
KUTA 1500 100	KWYO 1370 100	WABI 1200 100
Salt Lake City, Utah	Sheridan, Wyo.	Bangor, Maine
KVAK 1420 100	KXA 760 250	WABY 1370 100
Atchison, Kans.	Seattle, Wash.	Albany, N. Y.
KVAN 880 250	KXL 1420 100	WACO 1420 100
Vancouver, Wash.	Portland, Ore.	Waco, Texas
KVCV 1200 100	KXO 1500 100	WADC 1320 1000
Redding, Calif.	El Centro, Calif.	Akron, Ohio
KVEC 1200 100	KXOK 1250 1000	WAGA 1450 500
San Luis Obispo, Cal.	St. Louis, Mo.	Atlanta, Ga.
KVGB 1370 100	KXRO 1310 100	WAGF 1370 250
Great Bend, Kans.	Aberdeen, Wash.	Dothan, Ala.
KVI 570 1000	KXYZ 1440 1000	WAGM 1420 100
Tacoma, Wash.	Houston, Texas	Presque Isle, Me.
KVNU 1200 100	KYA 1230 1000	WAIM 1200 100
Logan, Utah	San Francisco, Calif.	Anderson, S. C.
KVOA 1260 1000	KYCA 1500 100	WAIR 1250 250
Tucson, Ariz.	Prescott, Ariz.	Winston-Salem, N. C.
KVOD 920 500	KYOS 1040 250	WALA 1380 500
Denver, Colo.	Merced, Calif.	Mobile, Ala.
KVOE 1500 100	KYSM 1500 100	WALR 1210 100
Santa Ana, Calif.	Mankato, Minn.	Zanesville, Ohio
KVOL 1310 100	KYW 1020 10000	WAML 1310 100
Lafayette, La.	Philadelphia, Pa.	Laurel, Miss.
KVOO 1140 25000	TGQ 1450 200	WAPI 1140 5000
Tulsa, Okla.	Quezaltenango, Guat.	Birmingham, Ala.
KVOR 1270 1000	TGW 1520 1000	WAPO 1420 100
Colo. Springs, Colo.	Guatemala City, Guat.	Chattanooga, Tenn.
KVOS 1200 100	TGX 1400 ....	WARD 1400 500
Bellingham, Wash.	Guatemala City, Guat.	Brooklyn, N. Y.

## NORTH AMERICAN B. C. STATIONS BY CALLS

WASH 1270 500	WBRY 1530 1000	WCOU 1210 100
Grand Rapids, Mich.	Waterbury, Conn.	Lewiston, Maine
WATL 1370 100	WBT 1080 50000	WCOV 1210 100
Atlanta, Ga.	Charlotte, N. C.	Montgomery, Ala.
WATR 1190 100	WBTH 1370 100	WCPO 1200 100
Waterbury, Conn.	Williamson, W. Va.	Cincinnati, Ohio
WAVE 940 1000	WBTM 1370 100	WCRW 1210 100
Louisville, Ky.	Danville, Va.	Chicago, Ill.
WAWZ 1350 500	WBZ 990 50000	WCSC 1360 500
Zarephath, N. J.	Boston, Mass.	Charleston, S. C.
WAYX 1200 100	WBZA 990 1000	WCSH 940 1000
Waycross, Ga.	Springfield, Mass.	Portland, Me.
WAZL 1420 100	WCAD 1220 500	WDAE 1220 1000
Hazleton, Pa.	Canton, N. Y.	Tampa, Fla.
WBAA 890 500	WCAE 1220 1000	WDAF 610 1000
West Lafayette, Ind.	Pittsburgh, Pa.	Kansas City, Mo.
WBAL 760 2500	WCAL 760 1000	WDAH 1310 100
Baltimore, Md.	Northfield, Minn.	El Paso, Texas
WBAL 1060 10000	WCAM 1280 500	WDAN 1500 250
Baltimore, Md.	Camden, N. J.	Danville, Ill.
WBAP 800 50000	WCAO 600 500	WDAS 1370 100
Port Worth, Texas	Baltimore, Md.	Philadelphia, Pa.
WBAX 1210 100	WCAP 1280 500	WDAY 940 1000
Wilkes-Barre, Pa.	Asbury Park, N. J.	Fargo, N. Dak.
WBBC 1400 500	WCAT 1200 100	WDBJ 930 1000
Brooklyn, N. Y.	Rapid City, S. Dak.	Roanoke, Va.
WBBL 1210 100	WCAU 1170 50000	WDBO 560 1000
Richmond, Va.	Philadelphia, Pa.	Oriando, Fla.
WBBM 770 50000	WCAX 1200 100	WDEL 1120 250
Chicago, Ill.	Burlington, Vt.	Wilmingon, Del.
WBBR 1300 1000	WCZA 1070 100	WDEV 550 500
Brooklyn, N. Y.	Carthage, Ill.	Waterbury, Vt.
WBBZ 1200 100	WCBA 1440 500	WDGY 1180 1000
Ponca City, Okla.	Allentown, Pa.	Minneapolis, Minn.
WBCM 1410 500	WCBD 1080 5000	WDNC 1500 100
Bay City, Mich.	Chicago, Ill.	Durham, N. C.
WBEN 900 1000	WCBM 1370 100	WDDO 1280 1000
Buffalo, N. Y.	Baltimore, Md.	Chattanooga, Tenn.
WBEO 1310 100	WCBS 1420 100	WDRG 1330 1000
Marquette, Mich.	Springfield, Ill.	Hartford, Conn.
WBHP 1200 100	WCOC 810 50000	WDSM 1200 100
Huntsville, Ala.	Minneapolis, Minn.	Superior, Wis.
WBIG 1440 1000	WCFL 970 5000	WDSU 1250 1000
Greensboro, N. C.	Chicago, Ill.	New Orleans, La.
WBIL 1100 5800	WCHS 580 500	WDWS 1370 100
New York, N. Y.	Charleston, W. Va.	Champaign, Ill.
WBLK 1370 100	WCHV 1420 100	WDZ 1020 250
Clarksburg, W. Va.	Charlottesville, Va.	Tuscola, Ill.
WBLY 1210 100	WCKY 1490 10000	WEAF 660 50000
Lima, Ohio	Covington, Ky.	New York, N. Y.
WBNO 1420 100	WCLE 610 500	WEAN 780 1000
New Orleans, La.	Cleveland, Ohio	Providence, R. I.
WBNS 1430 1000	WCLO 1200 100	WEAU 1050 1000
Columbus, Ohio	Janesville, Wis.	Eau Claire, Wis.
WBNX 1350 1000	WCLS 1310 100	WEBC 1290 1000
New York, N. Y.	Joliet, Ill.	Duluth, Minn.
WBNY 1370 100	WCMJ 1310 100	WEBQ 1210 100
Buffalo, N. Y.	Ashland, Ky.	Harrisburg, Ill.
WBOQ 860 50000	WCNW 1500 100	WEBR 1310 100
New York, N. Y.	Brooklyn, N. Y.	Buffalo, N. Y.
WBOW 1310 100	WCOA 1340 500	WEDC 1210 100
Terre Haute, Ind.	Pensacola, Fla.	Chicago, Ill.
WBRB 1210 100	WCOC 880 1000	WEED 1420 100
Red Bank, N. J.	Meridan, Miss.	Rocky Mount, N. C.
WBRC 930 1000	WCOL 1210 100	WEEL 590 1000
Birmingham, Ala.	Columbus, Ohio	Boston, Mass.
WBRE 1310 100	WCOP 1120 500	WEUU 830 1000
Wilkes-Barre, Pa.	Boston, Mass.	Reading, Pa.
WBRK 1310 100	WCOS 1370 100	WELI 900 500
Pittsfield, Mass.	Columbus, S. C.	New Haven, Conn.

NORTH AMERICAN B. C. STATIONS BY CALLS

WELL 1420	100	WGCM 1210	100	WHEC 1430	500
Battle Creek, Mich.		Gulfport, Miss.		Rochester, N. Y.	
WEMP 1310	100	WGES 1360	500	WHFC 1420	100
Milwaukee, Wis.		Chicago, Ill.		Cicero, Ill.	
WENR 870	50000	WGH 1310	100	WHIO 1260	1000
Chicago, Ill.		Newport News, Va.		Dayton, Ohio	
WENY 1200	250	WGIL 1500	250	WHIP 1480	5000
Elmira, N. Y.		Galesburg, Ill.		Hammond, Ind.	
WEOA 1370	100	WGL 1370	100	WHIS 1410	500
Evansville, Ind.		Fort Wayne, Ind.		Bluefield, W. Va.	
WESG 850	1000	WGKV 1500	100	WHJB 620	250
Elmira, N. Y.		Charleston, W. Va.		Greensburg, Pa.	
WEST 1200	100	WGN 720	50000	WHK 1390	1000
Easton, Pa.		Chicago, Ill.		Cleveland, Ohio	
WEVD 1300	1000	WGNC 1420	100	WHKC 640	500
New York, N. Y.		Gastonia, N. C.		Columbus, Ohio	
WEW 760	1000	WGNV 1210	100	WHLB 1370	100
St. Louis, Mo.		Newburgh, N. Y.		Virginia, Minn.	
WEXL 1310	50	WGPC 1420	100	WHLS 1370	250
Royal Oak, Mich.		Albany, Ga.		Port Huron, Mich.	
WFAA 800	50000	WGR 550	1000	WHMA 1420	100
Dallas, Texas		Buffalo, N. Y.		Anniston, Ala.	
WFAM 1200	100	WGRC 1370	250	WHN 1010	1000
South Bend, Ind.		New Albany, Ind.		New York, N. Y.	
WFAS 1210	100	WGRM 1210	100	WHO 1000	50000
White Plains, N. Y.		Grenada, Miss.		Des Moines, Iowa	
WFBC 1300	1000	WGST 890	1000	WHOM 1450	250
Greenville, S. C.		Atlanta, Ga.		Jersey City, N. J.	
WFBG 1310	100	WGTM 1310	100	WHP 1430	500
Altoona, Pa.		Wilson, N. C.		Harrisburg, Pa.	
WFBL 1360	1000	WGY 790	50000	WIBA 1280	1000
Syracuse, N. Y.		Schenectady, N. Y.		Madison, Wis.	
WFBM 1230	1000	WHA 940	5000	WIBC 1050	1000
Indianapolis, Ind.		Madison, Wis.		Indianapolis, Ind.	
WFBR 1270	500	WHA1 1210	250	WIBG 970	100
Baltimore, Md.		Greenfield, Mass.		Glenside, Pa.	
WFDF 1310	100	WHAM 1150	50000	WIBM 1370	100
Flint, Mich.		Rochester, N. Y.		Jackson, Mich.	
WFEA 1340	500	WHAS 820	50000	WIBU 1210	100
Manchester, N. H.		Louisville, Ky.		Poynette, Wis.	
WFIL 560	1000	WHAT 1310	100	WIBW 580	1000
Philadelphia, Pa.		Philadelphia, Pa.		Topeka, Kans.	
WFLA 620	1000	WHAZ 1300	1000	WIBX 1200	100
Tampa, Fla.		Troy, N. Y.		Utica, N. Y.	
WFMD 900	500	WHB 860	1000	WICA 940	250
Frederick, Md.		Kansas City, Mo.		Ashtabula, Ohio	
WFMJ 1420	100	WHBB 1500	100	WICC 600	500
Youngstown, Ohio		Selma, Ala.		Bridgeport, Conn.	
WFNC 1340	250	WHBC 1200	100	WIL 1200	100
Fayetteville, N. C.		Canton, Ohio		St. Louis, Mo.	
WFOR 1370	100	WHBF 1210	100	WILL 580	1000
Hattiesburg, Miss.		Rock Island, Ill.		Urbana, Ill.	
WFOY 1210	100	WHBI 1250	1000	WILM 1420	100
St. Augustine, Fla.		Newark, N. J.		Wilmington, Del.	
WFTC 1200	100	WHBL 1300	250	WIND 560	1000
Kinston, N. C.		Sheboygan, Wis.		Gary, Ind.	
WGAL 1500	100	WHBQ 1370	100	WINS 1130	1000
Lancaster, Pa.		Memphis, Tenn.		New York, N. Y.	
WGAN 640	500	WHBU 1210	100	WIOD 610	1000
Portland, Me.		Anderson, Ind.		Miami, Fla.	
WGAR 1450	1000	WHBY 1200	100	WIP 610	1000
Cleveland, Ohio		Green Bay, Wis.		Philadelphia, Pa.	
WGAU 1310	100	WHDF 1370	100	WIRE 1400	1000
Athens, Ga.		Calumet, Mich.		Indianapolis, Ind.	
WGBB 1210	100	WHDH 830	1000	WIS 560	1000
Freeport, N. Y.		Boston, Mass.		Columbia, S. C.	
WGBF 630	500	WHDL 1400	250	WISN 1120	250
Evansville, Ind.		Olean, N. Y.		Milwaukee, Wis.	
WGBI 880	500	WHEB 740	250	WJAC 1310	100
Seranton, Pa.		Portsmouth, N. H.		Johnstown, Pa.	

## NORTH AMERICAN B. C. STATIONS BY CALLS

WJAG	1060	1000	WKBJ	1500	100	WMBS	1420	100
Norfolk, Neb.			Muskegon, Mich.			Uniontown, Pa.		
WJAR	890	1000	WKEU	1500	100	WMC	780	1000
Providence, R. I.			Griffin, Ga.			Memphis, Tenn.		
WJAS	1290	1000	WKOK	1210	100	WMCA	570	1000
Pittsburgh, Pa.			Sunbury, Pa.			New York, N. Y.		
WJAX	900	1000	WKRC	550	1000	WMEX	1500	100
Jacksonville, Fla.			Cincinnati, Ohio			Boston, Mass.		
WJBC	1200	100	WKST	1250	250	WMFD	1370	100
Bloomington, Ill.			New Castle, Pa.			Wilmington, N. C.		
WJBK	1500	100	WKY	990	1000	WMFF	1310	100
Detroit, Mich.			Oklahoma City, Okla.			Plattsburg, N. Y.		
WJBL	1200	100	WKZO	590	1000	WMFG	1210	100
Decatur, Ill.			Kalamazoo, Mich.			Hibbing, Minn.		
WJBO	1120	500	WLAC	1470	5000	WMFJ	1420	100
Baton Rouge, La.			Nashville, Tenn.			Daytona Beach, Fla.		
WJBW	1200	100	WLAK	1310	100	WMFO	1370	100
New Orleans, La.			Lakeland, Fla.			Decatur, Ala.		
WJBY	1210	100	WLAP	1420	100	WMFR	1200	100
Gadsden, Ala.			Lexington, Ky.			High Point, N. C.		
WJDX	1270	1000	WLAW	680	1000	WMIN	1370	100
Jackson, Miss.			Lawrence, Mass.			St. Paul, Minn.		
WJEJ	1210	100	WLB	760	1000	WMMN	890	500
Hagerstown, Md.			Minneapolis, Minn.			Fairmont, W. Va.		
WJHL	1200	100	WLBC	1310	100	WMPC	1200	100
Johnson City, Tenn.			Muncie, Ind.			Lapeer, Mich.		
WJHP	1290	250	WLBL	900	5000	WMPS	1430	500
Jacksonville, Fla.			Stevens Point, Wis.			Memphis, Tenn.		
WJIM	1210	100	WLBZ	620	500	WMRO	1250	250
Lansing, Mich.			Bangor, Me.			Aurora, Ill.		
WJJD	1130	20000	WLEU	1420	100	WMSD	1420	100
Chicago, Ill.			Erie, Pa.			Muscle Shoals C., Ala.		
WJLS	1210	100	WLLH	1370	100	WMT	600	1000
Beckley, W. Va.			Lawrence, Mass.			Cedar Rapids, Iowa		
WJMC	1210	250	WLLH	1370	100	WNAC	1230	1000
Rice Lake, Wis.			Lowell, Mass.			Boston, Mass.		
WJMS	1420	100	WLNH	1310	100	WNAD	1010	1000
Ironwood, Mich.			Laconia, N. H.			Norman, Okla.		
WJNO	1200	100	WLS	870	50000	WNAX	570	1000
W. Palm Beach, Fla.			Chicago, Ill.			Yankton, S. D.		
WJR	750	50000	WLTH	1400	500	WNBC	1380	250
Detroit, Mich.			New York, N. Y.			New Britain, Conn.		
WJRD	1200	250	WLVA	1200	100	WNBF	1500	100
Tuscaloosa, Ala.			Lynchburg, Va.			Binghamton, N. Y.		
WJSV	1460	10000	WLW	700	500000	WNBH	1310	100
Washington, D. C.			Cincinnati, Ohio			New Bedford, Mass.		
WJTN	1210	100	WMAL	630	250	WNBX	1260	1000
Jamestown, N. Y.			Washington, D. C.			Springfield, Vt.		
WJW	1210	100	WMAQ	670	50000	WNBZ	1290	100
Akron, Ohio			Chicago, Ill.			Saranac Lake, N. Y.		
WJZ	760	50000	WMAS	1420	100	WNEL	1290	1000
New York, N. Y.			Springfield, Mass.			San Juan, P. R.		
WKAQ	1240	1000	WMAZ	1180	1000	WNEW	1250	1000
San Juan, P. R.			Macon, Ga.			New York, N. Y.		
WKAR	850	1000	WMBC	1420	100	WNLC	1500	100
East Lansing, Mich.			Detroit, Mich.			New London, Conn.		
WKAT	1500	100	WMBD	1440	1000	WNOX	1010	1000
Miami Beach, Fla.			Peoria, Ill.			Knoxville, Tenn.		
WKBB	1500	100	WMBF	610	1000	WNYC	810	1000
East Dubuque, Ill.			Miami, Fla.			New York, N. Y.		
WKBH	1380	1000	WMBG	1350	500	WOAI	1190	50000
LaCrosse, Wis.			Richmond, Va.			San Antonio, Texas		
WKBN	570	500	WMBH	1420	100	WOC	1370	100
Youngstown, Ohio			Joplin, Mo.			Davenport, Iowa		
WKBO	1200	100	WMBI	1080	5000	WOCB	1210	100
Harrisburg, Pa.			Chicago, Ill.			Barnstable, Mass.		
WKBV	1500	100	WMBO	1310	100	WOI	640	5000
Richmond, Ind.			Auburn, N. Y.			Ames, Iowa		
WKBW	1480	5000	WMBR	1370	100	WOKO	1430	500
Buffalo, N. Y.			Jacksonville, Fla.			Albany, N. Y.		

NORTH AMERICAN B. C. STATIONS BY CALLS

WOL	1230	1000	WRBL	1200	100	WSMK	1380	250
Washington, D. C.			Columbus, Ga.			Dayton, Ohio		
WOLS	1200	100	WRC	950	1000	WSNJ	1210	100
Florence, S. C.			Washington, D. C.			Bridgeton, N. J.		
WOMI	1500	100	WRDO	1370	100	WSOC	1210	100
Owensboro, Ky.			Augusta, Me.			Charlotte, N. C.		
WOMT	1210	100	WRDW	1500	100	WSPA	920	1000
Manitowoc, Wis.			Augusta, Ga.			Spartanburg, S. C.		
WOOD	1270	500	WREC	600	1000	WSPD	1340	1000
Grand Rapids, Mich.			Memphis, Tenn.			Toledo, Ohio		
WOPI	1500	100	WREN	1220	1000	WSPR	1140	500
Bristol, Tenn.			Lawrence, Kans.			Springfield, Mass.		
WOR	710	50000	WRGA	1500	100	WSTP	1500	100
Newark, N. J.			Rome, Ga.			Salisbury, N. C.		
WORC	1230	500	WRJN	1370	100	WSUJ	880	500
Worcester, Mass.			Racine, Wis.			Iowa City, Iowa		
WORK	1320	1000	WRKL	1500	100	WSUN	620	1000
York, Pa.			Rock Hill, S. C.			St. Petersburg, Fla.		
WORL	920	500	WRNL	880	500	WSVA	550	500
Boston, Mass.			Richmond, Va.			Harrisonburg, Va.		
WOSU	570	750	WROK	1410	500	WSVS	1370	50
Columbus, Ohio			Rockford, Ill.			Buffalo, N. Y.		
WOV	1130	1000	WROL	1310	100	WSYB	1500	100
New York, N. Y.			Knoxville, Tenn.			Rutland, Vt.		
WOW	590	1000	WRR	1280	500	WSYR	570	1000
Omaha, Neb.			Dallas, Texas			Syracuse, N. Y.		
WOWO	1160	10000	WRTD	1500	100	WSYU	570	1000
Fort Wayne, Ind.			Richmond, Va.			Syracuse, N. Y.		
WPAD	1420	100	WRUF	830	5000	WTAD	900	1000
Paducah, Ky.			Gainesville, Fla.			Quincy, Ill.		
WPAR	1420	100	WRVA	1110	5000	WTAG	580	1000
Parkersburg, W. Va.			Richmond, Va.			Worcester, Mass.		
WPAX	1210	100	WSAI	1330	1000	WTAL	1310	100
Thomasville, Ga.			Cincinnati, Ohio			Tallahassee, Fla.		
WPAY	1370	100	WSAJ	1310	100	WTAM	1070	50000
Portsmouth, Ohio			Grove City, Pa.			Cleveland, Ohio		
WPEN	920	1000	WSAL	1200	250	WTAQ	1330	1000
Philadelphia, Pa.			Salisbury, Md.			Green Bay, Wis.		
WPG	1100	5000	WSAN	1440	500	WTAR	780	1000
Atlantic City, N. J.			Allentown, Pa.			Norfolk, Va.		
WPIC	780	250	WSAR	1450	1000	WTAW	1120	500
Sharon, Pa.			Fall River, Mass.			College Station, Tex.		
WPIV	1210	100	WSAU	1370	100	WTAX	1210	100
Petersburg, Va.			Wausau, Wis.			Springfield, Ill.		
WPRA	1370	100	WSAV	1310	100	WTBO	800	250
Mayaguez, P. R.			Savannah, Ga.			Cumberland, Md.		
WPRO	630	500	WSAY	1210	100	WTCN	1250	1000
Providence, R. I.			Rochester, N. Y.			Minneapolis, Minn.		
WPRP	1420	100	WSAZ	1190	1000	WTEL	1310	100
Ponce, P. R.			Huntington, W. Va.			Philadelphia, Pa.		
WPTF	680	5000	WSB	740	50000	PHLT	1200	100
Raleigh, N. C.			Atlanta, Ga.			Hartford, Conn.		
WQAM	560	1000	WSBC	1210	100	WTIC	1040	50000
Miami, Fla.			Chicago, Ill.			Hartford, Conn.		
WQAN	880	500	WSBT	1360	500	WTJS	1310	100
Scranton, Pa.			South Bend, Ind.			Jackson, Tenn.		
WQBC	1360	1000	WSFA	1410	500	WTMA	1210	100
Vicksburg, Miss.			Montgomery, Ala.			Charleston, S. C.		
WQDM	1390	1000	WSGN	1310	100	WTMJ	620	1000
St. Albans, Vt.			Birmingham, Ala.			Milwaukee, Wis.		
WQXR	1550	1000	WSIX	1210	100	WTMW	1500	100
New York, N. Y.			Nashville, Tenn.			East St. Louis, Ill.		
WRAK	1370	100	WSJS	1310	100	WTNJ	1280	500
Williamsport, Pa.			Winston-Salem, N. C.			Trenton, N. J.		
WRAL	1210	100	WSLI	1420	100	WTOC	1260	1000
Raleigh, N. C.			Jackson, Miss.			Savannah, Ga.		
WRAW	1310	100	WSM	650	50000	WTOL	1200	100
Reading, Pa.			Nashville, Tenn.			Toledo, Ohio		
WRAX	920	1000	WSMB	1320	1000	WTRC	1310	100
Philadelphia, Pa.			New Orleans, La.			Elkhart, Ind.		

## NORTH AMERICAN B. C. STATIONS BY CALLS

WTRY	950	1000	XEBP	1150	250	XEK	990	100
Troy, N. Y.			Durango, Dgo.			Mexico City, D. F.		
WVFW	1400	500	XEBS	1340	200	XEKL	1240	500
Brooklyn, N. Y.			Mexico City, D. F.			Leon, Guan.		
WWAE	1200	100	XEBU	1240	50	XEL	1150	250
Hammond, Ind.			Chihuahua, Chih.			Mexico City, D. F.		
WWJ	920	1000	XEBW	1340	250	XELO	730	50000
Detroit, Mich.			Chihuahua, Chih.			Tijuana, B. Cfa.		
WWL	850	50000	XEBX	640	250	XELZ	1370	100
New Orleans, La.			Sabinsas, Coah.			Mexico City, D. F.		
WWNC	570	1000	XEBZ	810	100	XEM	1380	500
Asheville, N. C.			Mexico City, D. F.			Chihuahua, Chih.		
WWRL	1500	100	XEC	1150	100	XEME	1240	50
Woodside, N. Y.			Tijuana, L. C.			Merida, Yuc.		
WWSW	1500	100	XECA	1230	250	XEMO	860	5000
Pittsburgh, Pa.			Tampico, Tam.			Tijuana, L. C.		
WWVA	1160	5000	XECH	1490	250	XEMU	580	250
Wheeling, W. Va.			Toluca, Mex.			Piedras Negras, Coah.		
WXYZ	1240	1000	XECL	960	1000	XEMX	1280	100
Detroit, Mich.			Mexicali, B. Cfa.			Mexico City, D. F.		
W3XDD	....	50000	XECZ	1370	100	XEN	780	1000
Whippany, N. J.			San Luis Potosi, S.L.P.			Mexico City, D. F.		
W3XJ	1060	100	XED	1160	2500	XENT	910	150000
College Park, Md.			Guadalajara, Jal.			Nuevo Laredo, Tams.		
XEAA	750	200	XEDA	1220	200	XEP	1160	500
Mexicali, B. C.			Gral. Anaya, D. F.			Juarez, Chih.		
XEAC	980	5000	XEDF	810	100	XEPN	730	100000
Tijuana, B. Cfa.			Nuevo Laredo, Tams.			Piedras Negras, Coah.		
XEAF	990	750	XEDH	1340	200	XEQ	710	50000
Nogales, Son.			Villa Acuna, Coah.			Mexico City, D. F.		
XEAG	1310	10	XEDP	1080	500	XERA	840	250000
Cordoba, Ver.			Mexico City, D. F.			Villa Acuna, Coah.		
XEAI	1250	500	XEDR	1490	100	XERB	1090	150000
Mexico City, D. F.			Guaymas, Son.			Rosario Beach, B. Cfa.		
XEAL	660	1000	XEDW	1150	300	XERC	870	500
Mexico City, D. F.			Minatitlan, Ver.			Mexico City, D. F.		
XEAM	750	25	XEE	1210	50	XERH	1430	500
Matamoros, Tams.			Durango, Dgo.			Mexico City, D. F.		
XEAO	660	250	XEF	1450	100	XES	990	250
Mexicali, B. C.			Juarez, Chih.			Tampico, Tams.		
XEAP	1340	50	XEFB	870	200	XET	690	5000
Obregon, Son.			Monterrey, N. L.			Monterrey, N. L.		
XEAS	1160	100	XEFC	1340	100	XETB	1310	500
Saltillo, Coah.			Merida, Yuc.			Torreón, Coah.		
XEAT	1210	250	XEFE	980	250	XETH	1210	100
Parral, Chih.			Nuevo Laredo, Tams.			Puebla, Pue.		
XEAW	960	100000	XEFI	1440	250	XEU	1010	250
Reynosa, Tams.			Chihuahua, Chih.			Veracruz, Ver.		
XEB	1030	10000	XEFO	940	5000	XEW	890	100000
Mexico City, D. F.			Mexico City, D. F.			Mexico City, D. F.		
XEBA	1030	20	XEFQ	1010	50	XEX	1310	500
Guzman, Jal.			Cananea, Son.			Monterrey, N. L.		
XEBG	820	1000	XEFV	1210	50	XEXB	1270	250
Tijuana, B. Cfa.			Juarez, Chih.			Jalapa, Ver.		
XEBH	930	500	XEFW	1310	300	XEXD	1340	350
Hermosillo, Sonora			Tampico, Tams.			Orizaba, Ver.		
XEBI	1000	250	XEG	1230	250	XEXE	1270	17
Aguascalientes, Ags.			Monterrey, N. L.			Texcoco, Mex.		
XEBK	1030	100	XEH	720	250	XEXX	1170	1000
Neuvo Laredo, Tams.			Monterrey, N. L.			Mexico City, D. F.		
XEBL	1220	50	XEI	1370	125	XEZ	630	500
Mazatlan, Sin.			Morelia, Mich.			Merida, Yuc.		
XEBO	1310	25	XEJ	1020	1000	YSS	640	500
Irapuato, Guan.			Juarez, Chih.			San Salvador, E. S.		
			XEJP	1130	100	ZNS	540	400
			Mexico City, D. F.			Nassau, Bahamas		

# BROADCASTING STATIONS OF NORTH AMERICA

Compiled from RADEX records, with the assistance of Ed. M. Vichers.

This supplementary call letter index began in the September, 1938 issue of RADEX, and will appear on these pages every month until completed.

The abbreviations used throughout this list are familiar to all our readers, except perhaps "CP" for Construction Permit, "LS" for Local Sunset, and "ss" for sunset.

KROD, 1500 kcs., El Paso, Texas, Construction Permit appealed by KTSM, and sent to District of Columbia Court of Appeals.

KROW, Oakland, Calif., 930 kcs., 1000 w. unlt'd. *Trans:* 1520 Eighth Ave. *Aerial:* 2 towers, 128 ft. *Veries:* for postage. *Manager:* H. P. Frey. *Licensee:* Educational Brdctg. Corp., 464 - 19th St.

KROY, Sacramento, Calif., 1210 kcs., 100 w. days. *Network:* CBS. *Trans:* 65th St. and 14th Ave. *Aerial:* vertical, 179 ft. *Veries:* for postage. *Manager:* E. E. Wolfle. *Licensee:* Royal Miller, 10th and "K" Sts.

KRQA, Santa Fe, N. Mex., 1310 kcs., 100 w. unlt'd. *Aerial:* 2 towers, 65 ft. *Veries:* for postage. *Licensee:* J. Laurance Martin, 759 Cerrillos Road (Box 985).

KRRV, Sherman, Texas, 1310 kcs., 250 w. days. *Network:* MBS. *Aerial:* vertical, 179 ft. *Veries:* for postage. *Manager:* L. L. Hendrick. *Licensee:* Red River Valley Brdctg. Corp., 1910 S. Crockett St.

KRSC, Seattle, Wash., 1120 kcs., 250 w. unlt'd. *Network:* Pacific North West. *Aerial:* vertical, 218 ft. *Veries:* for postage. *Manager:* Robert E. Priebe. *Licensee:* Radio Sales Corp., Washington Athletic Club, 819 Fairview Place.

KSAC, Manhattan, Kans., 580 kcs., 500 w. nights, 1 kw days to LS, sharing time with WIBW. *Aerial:* 2 towers, 160 ft. *Veries:* for postage. *Program Director:* L. L. Longsdorf. *Licensee:* State College of Agriculture and Applied Science.

KSAL, Salina, Kans., 1500 kcs., 100 w. nights, 250 w. to LS, unlt'd. *Trans:* State Street Road. *Aerial:* vertical, 194 ft. *Manager:* A. E. Crockett. *Licensee:* Station KSAL, Journal Bldg.

KSAM, Huntsville, Texas, 1500 kcs., 100 w. days to LS. *Licensee:* Sam Houston Broadcasting Association. (Started broadcasting Dec. 10, 1938).

KSAN, San Francisco, Calif., 1420 kcs., 100 w. unlt'd. Was formerly KGGC. *Manager:* S. H. Patterson. *Licensee:* Golden Gate Broadcasting Co., 1355 Market St.

KSCJ, Sioux City, Iowa, 1339 kcs., 1000 w. nights, 5 kw to LS, unlt'd. *Network:* CBS. *Trans:* Leeds, on Highway 75. *Aerial:* vertical, 313 ft. *Manager:* C. W. Corkhill. *Licensee:* Sioux City Journal, Perkins Bros. Co., 415 Douglas St.

KSD, St. Louis, Mo., 550 kcs., 1000 w. nights, 5 kw to LS, sharing time with KFUE. *Network:* NBC-Red. *Aerial:* 2 towers, 100 ft. and one tower, 150 ft., directional at night. *Manager:* Geo. M. Burbach. *Licensee:* St. Louis Post-Dispatch, Pulitzer Publishing Co., 12th and Olive Sts.

KSEI, Pocatello, Idaho, 900 kcs., 250 watts nights, 1 kw to LS, unlt'd. *Network:* National. *Aerial:* 2 towers, 165 ft. *Manager:* Henry H. Fletcher. *Licensee:* Radio Service Corp., 141 S. 6th St.

KSFO, San Francisco, Calif., 560 kcs., 1000 w. nights, 5 kw to LS, unlt'd. *Network:* CBS. *Transmitter:* Pier 92. *Aerial:* vertical, 400 ft. *Manager:* Philip G. Lasky. *Licensee:* Associated Broadcasters, Inc., Russ Bldg.

KSL, Salt Lake City, Utah, 1130 kcs., 50 kilowatts unlt'd. *Network:* CBS. *Transmitter:* Saltair. *Aerial:* 2 towers, 225 ft. *Manager:* Earl J. Glade. *Licensee:* Radio Service Corp., Vermont Bldg.

KSLM, Salem, Ore., 1370 kcs., 100 w. unlt'd. *Network:* MBS. *Aerial:* vertical, 130 ft. *Permits:* Has CP to move to 1360 kcs with 500 watts. *Manager:* Thomas Hoxie. *Licensee:* Oregon Radio Inc., 343 Court St.

KSO, Des Moines, Iowa, 1430 kcs., 500 w. nights, 2500 watts to LS, unlt'd. *Networks:* MBS, and NBC-Blue. *Aerial:* vertical, 370 ft. *Manager:* Luther L. Hill. *Licensee:* Iowa Broadcasting Co., 715 Locust St.

KSOO, Sioux Falls, S. Dak., 1110 kcs., 5000 watts limited time. *Networks:* NBC. *Aerial:* vertical, 234 ft. *Manager:* Joseph Henkin. *Licensee:* Sioux Falls Broadcast Ass'n., Inc., Carpenter Hotel.

KSRO, Santa Rosa, Calif., 1310 kcs., 100 w. nights, 250 w. to LS, unlt'd. *Aerial:* vertical, 200 ft. *Manager:* Russell Bjorn. *Licensee:* Press-Democrat Publishing Co.

KSTP, St. Paul, Minn., 1460 kcs., 10 kw nights, 25 kw to LS, unlt'd. *Network:* NBC-Red. *Aerial:* vertical, 165 ft. *Manager:* Stanley E. Hubbard. *Licensee:* National Battery Brdctg. Co., St. Paul Hotel.

KSUB, Cedar City, Utah, 1310 kcs., 100 w. unlt'd. *Aerial:* vertical, 160 ft. *Manager:* Archie L. Madsen. *Licensee:* Harold Perry Johnson and Leland M. Perry, El Escalante Hotel.

KSUN, Lowell, Ariz., 1200 kcs., 100 w. nights, 250 w. to LS, unlt'd. *Network:* Arizona. *Aerial:* vertical, 210 ft. *Manager:* Carleton W. Morris. *Licensee:* Copper Electric Co., Inc., Drawer C.

KTAR, Phoenix, Ariz., 620 kcs., 1000 w. unlt'd. *Network:* NBC. *Aerial:* 2 towers, 179 ft. on top of building. *Manager:* Richard O. Lewis. *Licensee:* KTAR Brdctg. Co., 711 Heard Bldg.

KTAT, Fort Worth, Texas, 1240 kcs., 1000 w. unlt'd. *Network:* MBS. *Transmitter:* Birdville. *Aerial:* vertical, 200 ft. *Manager:* Sam H. Bonnett. *Licensee:* Tarrant Brdctg. Co., Hotel Texas.

KTBC, Austin, Texas, 1120 kcs., 1000 w. to LS (Under Construction). *State Capitol Brdctg. Ass'n.*

KTBS, Shreveport, La., 1450 kcs., 1000 w. unlt'd. *Network:* NBC. *Aerial:* 2 towers, 196 ft. *Manager:* John C. McCormack. *Licensee:* Tri-State Brdctg. System, Inc., Box 17.

KTEM, Temple, Texas, 1370 kcs., 250 w. to LS. *Network:* MBS. *Aerial:* vertical, 175 ft. *Manager:* Burton Bishop. *Licensee:* Bell Broadcasting Co., Kyle Hotel,

- KTFI, Twin Falls, Idaho, 1240 kcs, 1000 w. unlt'd. *Network:* NBC. *Aerial:* vertical, 437 ft. *Manager:* John E. Gardner. *Licensee:* Radio Broadcasting Corp., Box 521.
- KTHS, Hot Springs, Ark., 1040 kcs, 1000 w. (Using 1060 kcs, 10000 watts, specified hours, under special authorization). *Network:* NBC. *Aerial:* 2 towers, 200 ft. *Manager:* S. A. Cisler. *Licensee:* Chamber of Commerce, Box 86.
- KTKC, Visalia, Calif., 1190 kcs, 250 w. to LS. *Network:* MBS. *Aerial:* vertical, 195 ft. *Manager:* Charles P. Scott. *Licensee:* Tulare-Kings Counties Radio Ass'n.
- KTMS, Santa Barbara, Calif., 1220 kcs, 500 w. unlt'd. *Network:* NBC-Blue. *Transmitter:* near Goleta, Calif. *Aerial:* directional, two towers, 250 ft. *Manager:* Norman R. McLaughlin. *Licensee:* News Press Publishing Co.
- KTOH, Lihue, Hawaii, 1500 kcs, 100 w. nights, 250 w. to LS, unlt'd. (Under Construction). Garden Island Publishing Co.
- KTOK, Oklahoma City, Okla., 1370 kcs, 100 w. unlt'd. *Networks:* NBC and MBS. *Aerial:* vertical, 210 ft. *Manager:* Joseph W. Lee. *Licensee:* Oklahoma Brdctsg. Co., Inc., 1113 N. Broadway.
- KTRB, Modesto, Calif., 740 kcs, 250 w. to LS. *Aerial:* 2 towers, 54 ft. *Manager:* T. R. McTammany. *Licensee:* McTammany & Bates, Box 405.
- KTRH, Houston, Texas, 1290 kcs, 1000 w. nights, 5 kw to LS, unlt'd. *Network:* CBS. *Transmitter:* Deepwater. *Aerial:* vertical, 375 ft. *Manager:* B. F. Orr. *Licensee:* KTRH Broadcasting Co., Rice Hotel.
- KTRI, Sioux City, Iowa, 1420 kcs, 100 w. nights, 250 w. to LS, unlt'd. *Manager:* Dietrich Dirks. *Licensee:* Sioux City Broadcasting Co.
- KTSA, San Antonio, Texas, 550 kcs, 1000 w. nights, 5 kw to LS, unlt'd. *Network:* CBS. *Transmitter:* St. Hedwig Road. *Aerial:* 2 towers, 200 ft. *Manager:* G. W. Johnson. *Licensee:* KTSA Brdctsg. Co., Gunter Hotel.
- KTSH, El Paso, Texas, 1310 kcs, 100 w. nights, 250 w. to LS. *Network:* NBC. *Transmitter:* Mills Bldg. *Aerial:* vertical, 158 ft. *Manager:* Karl O. Wyler. *Licensee:* Tri-State Brdctsg. Co., Inc., Box 1976 (Hotel Paseo del Norte).
- KTSW, Emporia, Kans., 1370 kcs, 100 w. to LS. (Under Construction). Emporia Brdctsg. Co., Inc.
- KTUL, Tulsa, Okla., 1400 kcs, 1000 w. nights, 5 kw to LS, unlt'd. *Network:* CBS. *Aerial:* vertical, 215 ft. *Manager:* W. C. Gillespie. *Licensee:* Tulsa Brdctsg. Co., Inc., National Bank Bldg.
- KTW, Seattle, Wash., 1220 kcs, 1000 w., Sundays only, sharing with KWSC. *Aerial:* 2 towers, 170 ft. *Manager:* Dr. M. A. Matthews. *Licensee:* First Presbyterian Church, 7th and Spring Sts.
- KUJ, Walla Walla, Wash., 1370 kcs, 100 w. unlt'd. *Aerial:* 2 towers, 130 ft. *Manager:* H. E. Studebaker. *Licensee:* KUJ, Inc., Marcus Whitman Hotel.
- KUMA, Yuma, Ariz., 1429 kcs, 100 w., specified hours. *Aerial:* vertical, 170 ft. *Manager:* E. N. Sturdivant. *Licensee:* Dr. A. H. Schermann, Box 267.
- KUOA, Siloam Springs, Ark., 1260 kcs, 5000 w. to LS. *Aerial:* vertical, 450 ft. *Manager:* C. M. Books. *Licensee:* KUOA, Inc., John Brown University.
- KUSD, Vermillion, S. Dak., 890 kcs, 500 w., sharing with KFNF. *Transmitter:* in Science Hall. *Aerial:* 2 towers, 100 ft. *Manager:* B. B. Brackett. *Licensee:* University of S. Dak.
- KUTA, Salt Lake City, Utah, 1500 kcs, 100 w. unlt'd. *Network:* NBC. *Aerial:* vertical, 164 ft. *Manager:* Frank C. Carman. *Licensee:* Utah Broadcasting Co.
- KVAK, Atchison, Kans., 1420 kcs, 100 w. to LS. (Under Construction). Carl Latenser is Licensee, and the transmitter will probably be in Buchanan County, Mo.
- KVAN, Vancouver, Wash., 880 kcs, 250 watts to LS. (Under Construction). Vancouver Radio Corp.
- KVCV, Redding, Calif., 1200 kcs, 100 w. unlt'd. *Aerial:* vertical, 178 ft. *Manager:* Harold Smithson. *Licensee:* Golden Empire Brdctsg. Co.
- KVEC, San Luis Obispo, Calif., 1200 kcs, 100 w. nights; 250 w. to LS, unlt'd. *Transmitter:* Morro Road. *Aerial:* vertical, 218 ft. *Manager:* Lee H. Hacker. *Licensee:* Valley Electric Co.
- KVGB, Great Bend, Kans., 1370 kcs, 100 w. unlt'd. *Transmitter:* South Great Bend. *Aerial:* vertical, 169½ ft. *Manager:* E. E. Ruehlen. *Licensee:* Ernest Edward Ruehlen.
- KVI, Tacoma, Wash., 570 kcs, 1000 w. nights, 5 kw to LS, unlt'd. *Network:* CBS. *Transmitter:* Point Heyer, Vashon Island. *Aerial:* Vertical, 444 ft. *Manager:* Mrs. Vernice D. Boulianne. *Licensee:* Puget Sound Brdctsg. Co., Inc., Rust Bldg.
- KVNU, Logan, Utah, 1200 kcs, 100 w. (Under Construction). Cache Valley Brdctsg. Co.
- KVOA, Tucson, Ariz., 1260 kcs, 100 w. unlt'd. *Aerial:* vertical, 190 ft. *Manager:* E. B. Williams. *Licensee:* Arizona Brdctsg. Co., Inc., Consolidated Nat'l. Bank Bldg.
- KVOD, Denver, Colo., 920 kcs, 500 w., sharing time with KFEL. *Network:* NBC-Blue. *Aerial:* vertical, 320 ft. *Manager:* J. C. Ekrem. *Licensee:* Colorado Radio Corp., Continental Oil Bldg.
- KVOE, Santa Ana, Calif., 1500 kcs., 100 w. unlt'd. *Network:* MBS. *Aerial:* vertical, 162 ft. *Manager:* Ernest L. Spencer. *Licensee:* The Voice of the Orange Empire, Ltd.
- KVOL, Lafayette, La., 1310 kcs, 100 w. nights, 250 w. to LS, unlt'd. *Aerial:* 2 towers, 90 ft. *Manager:* Geo. H. Thomas. *Licensee:* Evangeline Brdctsg. Co., Inc., Evangeline Hotel.
- KVOO, Tulsa, Okla., 1140 kcs., 25000 watts, unlt'd. *Network:* NBC. *Aerial:* directional at night, two towers, 225 ft. *Manager:* Wm. B. Way. *Licensee:* Southwestern Sales Corp., Wright Bldg.
- KVOR, Colorado Springs, Colo., 1270 kcs, 1000 w. unlt'd. *Network:* CBS. *Aerial:* vertical, 210 ft. *Manager:* Hugh B. Terry. *Licensee:* Out West Brdctsg. Co.
- KVOS, Bellingham, Wash., 1200 kcs, 100 w. unlt'd. *Network:* MBS. *Permit:* Has CP for 250 w. days. *Licensee:* KVOS, Inc., 115 W. Magnolia St.



## TURNER DIAL

(Continued from page 23)

The trio of young men had observed Turner's glance at the clock. They arose to leave. Turner held up his hand, and continued: "But sets that have good tuning circuits must be carefully checked for other troubles when image frequencies and double spots appear. You must look for internal coupling between parts of the receiver; poorly adjusted trimmers on the i. f. transformers; incorrect alignment of certain of the tuning condensers; defective or missing shielding of the oscillator units; and, last but not least, defective tube operation, particularly the mixer."



The map which heads this column shows, in solid black, the states in which we have at least five members enrolled in The Radex Club. Since last month we have filled up the states of Oregon, Vermont, Montana, Colorado, Iowa, Kansas, and Hawaii, Mexico, Ontario and Quebec. New countries added last month are Australia, Bahamas, Dominican Republic and Italy. With members in 47 states, all the territories, nearly all of Canada, and fourteen countries, we believe that The

Radex Club is the fastest growing radio club in the country.

The response to the Verified All Continents plan took us by surprise. While we expected a good response, we did not expect verifications to pour in faster than we could take care of them. We expect that by time this appears in print, however, that all the awards will be mailed out, and that we will be able to take care of other requests as they come in. For further information concerning the Verified All Continents plan, readers are referred to the February issue of RADEX.

We are pleased to announce the formation of the QRM Chapter of The Radex Club. This new chapter was organized by Elwin H. Covey, of Napa, California, and includes twelve members, all of them students at the Napa Union High School. The president is Elwin Covey, vice-president is Louis Coward, and secretary-treasurer is William Wendt. Meetings take place on Tuesdays and Thursdays from 12:30 to 1:05 pm at the school. The purpose of this chapter, as described by the president, is to learn, and to teach, the fundamentals of DXing. The name, "QRM", indicates their acceptance of the principles of the National Association for the Prevention of Radio Interference.

Membership in The Radex Club is available to anyone who is interested in DXing. There is no charge, and no obligation. Whether you are a subscriber or a newsstand reader, you can become a member of this club simply by making application on a postal card.

**THE IMPROVED RADEX  
WILL HELP YOUR FRIENDS TOO!  
WILL YOU PLEASE HELP BY  
TELLING THEM ABOUT IT?—The Editor**

## QUICK INDEX TO STATION DATA

### North American Broadcast

By Frequencies . . . . .	Mar. '39, p. 55
By Location . . . . .	Mar. '39, p. 76
By Calls . . . . .	Mar. '39, p. 83
Frequency Checks . . . . .	Feb. '39, p. 49
Names of Owners . . . . .	Nov. '38, p. 56
Owners' Address . . . . .	Oct. '38, p. 56
Time On The Air . . . . .	Feb. '39, p. 55

### Foreign Broadcast

By Frequencies . . . . .	Feb. '39, p. 46
By Locations . . . . .	Dec. '36, p. 52
By Calls . . . . .	Dec. '36, p. 57
Asia . . . . .	Feb. '38, p. 46
South America . . . . .	Oct. '38, p. 52
Europe . . . . .	June '37, p. 49

---

When requesting verifications from radio stations, return postage should always be sent. Return postage to foreign countries can be sent in the form of an International Reply Coupon, available at any post office at 9c each. Unused postage stamps from many foreign countries, which can be sent instead of Reply Coupons, are available from the Return Postage Bureau, 85 Francisco Ave., Rutherford, N. J.

---

## INSURE YOUR RADIO ENJOYMENT

SEND THIS BLANK TODAY

The Radex Publishing Co.,  
362 Cedar Lane,  
Teaneck, N. J.

Enclosed find \$..... for which send me postpaid my choice of your offers as checked below:

- One Radio World Map and Time Converter . . . . . 25c
- One copy of the next RADEX . . . . . 25c
- One year's subscription to RADEX, 10 issues . . . . . \$1.75
- Two years . . . . . \$3.25     Three years . . . . . \$4.75

(ADD 50c PER YEAR FOR FOREIGN SUBSCRIPTIONS, EXCEPT CANADA)

Print Name Plainly . . . . .

Street and Number . . . . .

City and State . . . . .

# THE DX CALENDAR

## Time Is Eastern Standard Special Programs

- Feb. 24, 5:40-6:30 am, WEAU, 1050 kcs., Eau Claire, Wis. (NRC).  
 Feb. 26, Commencing at 4 am, XEM, 1380 kcs., Chihuahua, Chih. (NRC).  
 Mar. 1, 4-5 am, CMBG, 690 kcs., Havana, Cuba, (URDXC).  
 Mar. 1, 3:30-4:30 am, CMCD, 630 kcs., Havana, Cuba, (URDXC).  
 Mar. 1, 3:30-4:30 am, COCD, 6130 kcs., Havana, Cuba, (PRDXC).  
 Mar. 2, 3-4 am, XEDR, 1490 kcs., Guaymas, Son. (URDXC).  
 Mar. 22, 1-2 am, YSD, 9694 kcs., San Salvador, E. S. (IDA).  
 Mar. 20, 1-2 am, YSS, 638 kcs., San Salvador, E.S. (IDA).

## Regular DX Programs

- Every Sunday:  
 10:15-10:45 am, CFCO, 630 kcs, Chatham, Ont.  
 First and Third Sunday:  
 2-4 am, WJBO, 1120 kcs, Baton Rouge, La.  
 Every Tuesday:  
 11:45 am-noon, W9XA, 26450 kcs, Kansas City, Mo.  
 Every Wednesday:  
 12:30 am, KOY, 1390 kcs., Phoenix, Ariz.  
 First and Third Wednesday:  
 1:45-2 pm, WTAR, 780 kcs, Norfolk, Va.  
 Every Thursday:  
 2:45-3 am, KSL, 1130 kcs, Salt Lake City, Utah. (Spatari announcements).  
 Every Saturday:  
 2:30-2:45 am, KLS, 1280 kcs., Oakland, Calif.  
 10:15-10:30 am, WEEU, 850 kcs, Reading, Pa.  
 First day of month:  
 4-4:30 am, WPAY, 1370 kcs., Portsmouth, Ohio.  
 Last day of month:  
 3-5 am, KWSC, 1220 kcs., Pullman, Wash.

A special program from CKCA, Kenora, Ont., has been arranged by the NRC for March 9, from 3 to 4 am, EST. Verifications will be sent for five cents.

## W8XO Back

The special authorization for operation with 500,000 watts by WLW has been terminated by the FCC. This Cincinnati station is now using only its licensed power of 50 kilowatts. Experimental tests may be conducted, however, over station W8XO, 700 kilocycles, with 500 kilowatts. Only non-commercial programs can be radiated by W8XO.

NEXT MONTH IN RADEX we shall extend the shortwave list to include the ultra high frequency and television stations.

## GET MORE

# DX

## WITH HEADPHONES



WE recommend the famous Trimm line of headphones for DX success. They are precision-built, and combine ultra-sensitivity with rugged construction.

- The Trimm "Featherweights" weigh but 4¼ ounces complete. 24,000 ohms. .... \$8.50  
 Trimm "Professional." 4000 ohms. .... 4.00  
 Trimm "Dependable." 2000 ohms. .... 3.25

## THE PERFECT PHONE ADAPTER

MAKES it easy to attach headphones to any radioset. Easily installed, without tools, in just a minute. The loudspeaker can be silenced while 'phones are being used. Ideal for the hard-of-hearing. The price is only \$3.95.

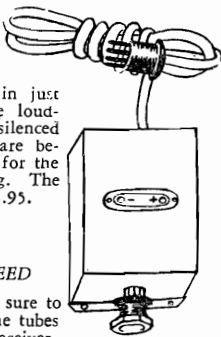

FULLY  
GUARANTEED

In ordering, be sure to give a list of the tubes used in the receiver.

## THE RADEX PUBLISHING CO.

362 Cedar Lane  
TEANECK, N. J.



J. E. SMITH, President  
National Radio Institute  
Established 1914

# I WILL TRAIN YOU TO START A SPARE TIME OR FULL TIME RADIO SERVICE BUSINESS WITHOUT CAPITAL

Here's  
Proof

Picked up  
\$1800 while  
Learning



"I picked up \$1800 while studying and I call that easy money—the time I gave my Radio work did not interfere with my other business." OTIS DENTON, 14105 Lorain Ave., Cleveland, Ohio

Own Business  
Pays \$300 a  
Month



"I now have my own Radio business which shows three hundred dollars a month profit — thanks again to National Radio."—FRANK T. REESE, 39 N. Felton St., Philadelphia, Penna.



Get My LESSON on Radio  
Servicing Tips FREE

I want to prove my Training is just what you need to master Radio. My sample lesson text, "Radio Receiver Troubles—Their Cause and Remedy" covers a long list of Radio receiver troubles in A.C., D.C. battery, universal, auto, T.R.F., super-heterodyne, all-wave, and other types of sets, cross-indexed for quick reference. Special section on receiver checkup, alignment, balancing, neutralizing, testing. Get this lesson Free. Mail the Coupon.

The world-wide use of Radio has made many opportunities for you to have a spare time or full time Radio service business of your own. Four out of every five homes in the United States have Radio sets which regularly need repairs, new tubes, etc. Servicemen can earn good commissions selling new sets to owners of old models. Even if you have no knowledge of Radio or electricity, I will train you at home in your spare time to sell, install, fix, all types of Radio sets & start your own Radio business and build it up on money you make in your spare time while learning. Mail coupon for my 64-page book. It's Free—it shows what I have done for others—that I am ready to do for you.

Many Make \$5, \$10, \$15 a Week Extra  
in Spare Time While Learning

The day you enroll I start sending Extra Money Job Sheets; show you how to do Radio repair jobs. Throughout your training I send plans and directions that made good spare time money—\$200 to \$500—for hundreds, while learning. I send you special Radio equipment to conduct experiments and build circuits. This 50-50 method of training makes learning at home interesting, fascinating, practical. I ALSO GIVE YOU A MODERN PROFESSIONAL, ALL-WAVE, ALL-PURPOSE RADIO SET SERVICING INSTRUMENT to help you make good money fixing Radios while learning and equip you for full time jobs after graduation.

Get Ready Now for Your Own Radio  
Business and for Jobs Like These

Radio broadcasting stations employ engineers, operators, station managers and

pay up to \$5,000 a year. Fixing Radio sets in spare time pays many \$200 to \$500 a year—full time jobs with Radio jobbers, manufacturers and dealers as much as \$30, \$50, \$75 a week. Many Radio Experts open full or part time Radio sales and repair businesses. Radio manufacturers and jobbers employ testers, inspectors, foremen, engineers, servicemen, and pay up to \$6,000 a year. Automobile, police, aviation, commercial Radio, loud speaker systems are new fields offering good opportunities now and for the future. Television promises to open many good jobs soon. Men I trained have good jobs in these branches of Radio. Read how they got their jobs. Mail Coupon.

Find Out What Radio Offers You

Act Today. Mail the coupon now for Sample Lesson and 64 page book. They're free to any fellow over 16 years old. They point out Radio's spare time and full time opportunities and those coming in Television; tell about my training in Radio and Television; show you letters from men I trained, telling what they are doing and earning. Find out what Radio offers YOU! MAIL COUPON in an envelope, or paste on a postcard—NOW!

J. E. SMITH,  
President  
Dept. 9C0  
National Radio  
Institute,  
Washington,  
D. C.



GOOD FOR BOTH 64 PAGE BOOK  
SAMPLE LESSON FREE

J. E. SMITH, President, Dept. 9C0  
National Radio Institute, Washington, D. C.

Dear Mr. Smith: Without obligating me, send your sample lesson and the book which tells about spare time and full time Radio opportunities, and how I can train for them at home in spare time.  
(Please write plainly.)

Name..... Age.....

Address .....

City ..... State.....